

Transfer Case and Extension Case Assembly

MANUAL TRANSMISSION AND DIFFERENTIAL

9. Transfer Case and Extension Case Assembly

A: REMOVAL

- 1) Remove the manual transmission assembly from the vehicle. <Ref. to 5MT-23, REMOVAL, Manual Transmission Assembly.>
- 2) Remove the back-up light switch and the neutral position switch. <Ref. to 5MT-35, REMOVAL, Switches and Harness.>
- 3) Remove the transfer case together with the extension case assembly.

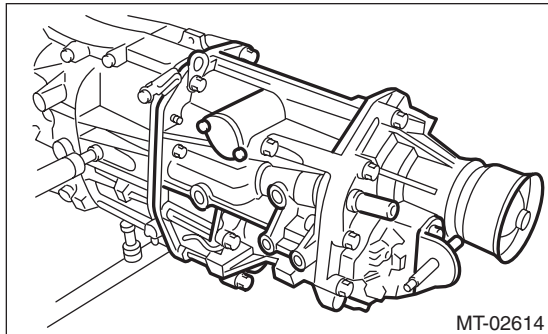

- 4) Remove the gasket.
- 5) Remove the shifter arm.
- 6) Remove the extension case assembly.

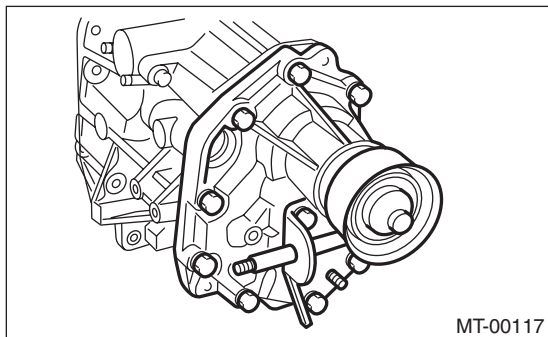

- 7) Remove the transfer driven gear.
- 8) Remove the bearing outer race and thrust washer from the extension case.

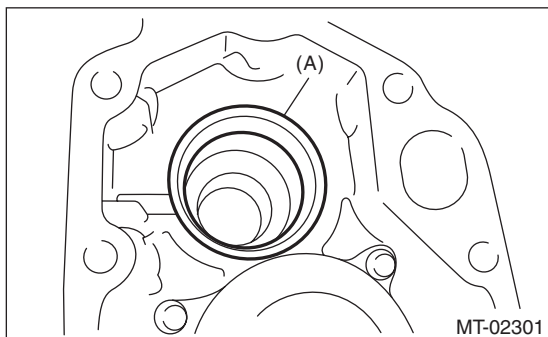

(A) Bearing outer race

B: INSTALLATION

- 1) Clean the mating surfaces of the transmission case, transfer case and extension case.
- 2) Apply a coat of grease to the front roller bearing and rear roller bearing of the transfer driven gear.

Grease:

NICHIMOLY N-130 or equivalent

- 3) Install the center differential and transfer driven gear into the transfer case.

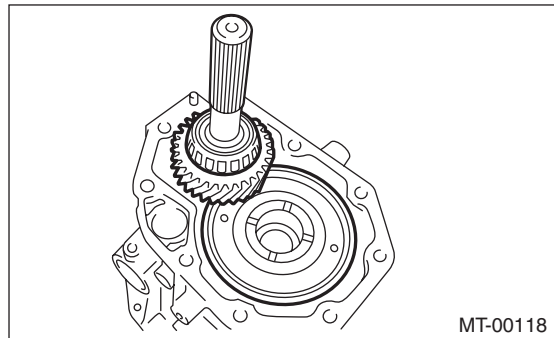

- 4) Install the bearing outer race to transfer driven gear.
- 5) While pressing the bearing outer race horizontally, rotate the driven shaft for ten turns.
- 6) Measure the height "W" between transfer case and taper roller bearing on the transfer driven gear.

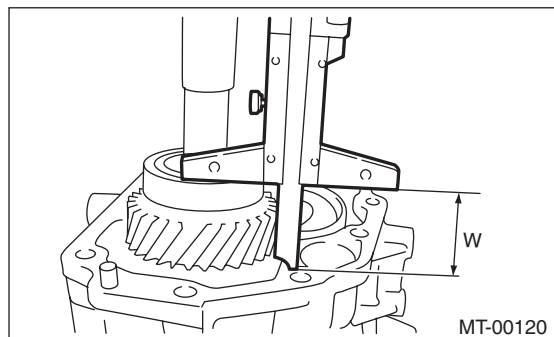

- 7) Measure depth "X" of bearing insertion part of the extension case.

NOTE:

Measure with bearing outer race and thrust washer removed.

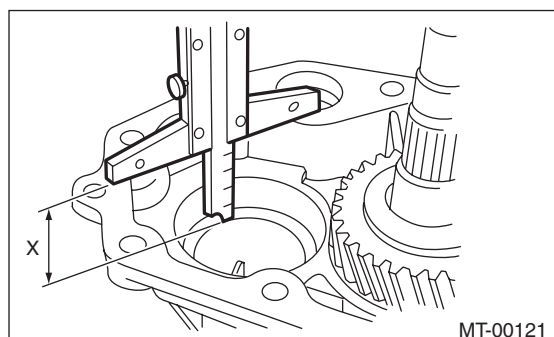

Transfer Case and Extension Case Assembly

MANUAL TRANSMISSION AND DIFFERENTIAL

8) Calculate the thrust washer thickness “t” using the following calculation.

$$t = X - W + (0.15 - 0.20 \text{ mm } (0.006 - 0.008 \text{ in}))$$

X: Depth of bearing insertion part of the extension case

W: Height between transfer case and taper roller bearing on the transfer driven gear.

0.15 — 0.20 mm (0.006 — 0.008 in): Amount of standard protrusion

9) Select the washer with the nearest value in the following table.

NOTE:

Be sure that it is always within the preload.

Preload of the taper roller bearing (amount of standard protrusion):

0.15 — 0.20 mm (0.006 — 0.008 in)

| Thrust washer (61 × 50 × t) | |
|-----------------------------|-------------------|
| Part No. | Thickness mm (in) |
| 803050060 | 0.50 (0.0197) |
| 803050061 | 0.55 (0.0217) |
| 803050062 | 0.60 (0.0236) |
| 803050063 | 0.65 (0.0256) |
| 803050064 | 0.70 (0.0276) |
| 803050065 | 0.75 (0.0295) |
| 803050066 | 0.80 (0.0315) |
| 803050067 | 0.85 (0.0335) |
| 803050068 | 0.90 (0.0354) |
| 803050069 | 0.95 (0.0374) |
| 803050070 | 1.00 (0.0394) |
| 803050071 | 1.05 (0.0413) |
| 803050072 | 1.10 (0.0433) |
| 803050073 | 1.15 (0.0453) |
| 803050074 | 1.20 (0.0472) |
| 803050075 | 1.25 (0.0492) |
| 803050076 | 1.30 (0.0512) |
| 803050077 | 1.35 (0.0531) |
| 803050078 | 1.40 (0.0551) |
| 803050079 | 1.45 (0.0571) |

10) Install the selected thrust washer and bearing outer race into the extension case.

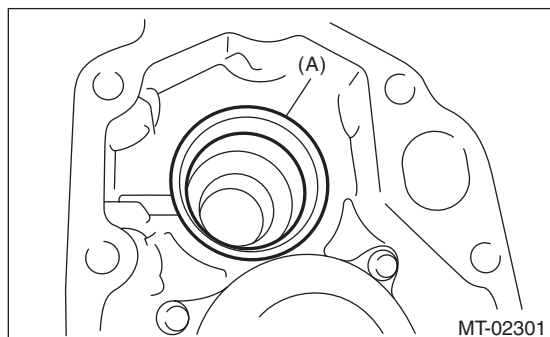

(A) Bearing outer race

11) Measure the depth “S” between transfer case and center differential.

ST 398643600 GAUGE

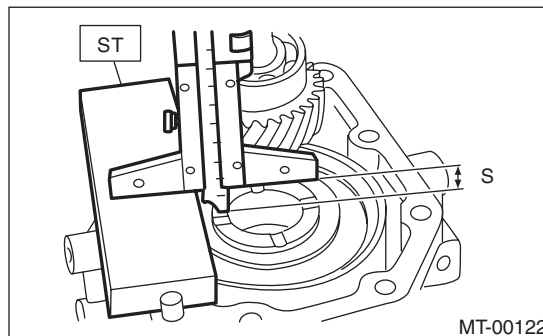

12) Measure the height “T” between the extension case and transfer drive gear.

ST 398643600 GAUGE

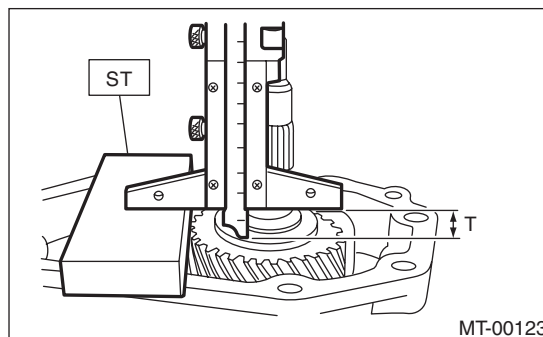

13) Calculate the thrust washer thickness “U” using the following calculation.

$$U = S + T - 30 \text{ mm } (1.18 \text{ in}) - (0.15 - 0.35 \text{ mm } (0.0059 - 0.0138 \text{ in}))$$

S: Depth between transfer case and center differential

T: Height between the extension case and transfer gear

30 mm (1.18 in): Thickness of ST

0.15 — 0.35 mm (0.0059 — 0.0138 in): Clearance

14) Select a suitable washer in the following table.

Clearance:

0.15 — 0.35 mm (0.0059 — 0.0138 in)

| Thrust washer | |
|---------------|-------------------|
| Part No. | Thickness mm (in) |
| 803036050 | 0.9 (0.035) |
| 803036054 | 1.0 (0.039) |
| 803036051 | 1.1 (0.043) |
| 803036055 | 1.2 (0.047) |
| 803036052 | 1.3 (0.051) |
| 803036056 | 1.4 (0.055) |
| 803036053 | 1.5 (0.059) |
| 803036057 | 1.6 (0.063) |
| 803036058 | 1.7 (0.067) |
| 803036080 | 1.8 (0.071) |
| 803036081 | 1.9 (0.075) |

Transfer Case and Extension Case Assembly

MANUAL TRANSMISSION AND DIFFERENTIAL

15) Install the selected thrust washer to center differential.

16) Apply a proper amount of liquid gasket to the transfer case mating surface.

Liquid gasket:

THREE BOND 1215 (Part No. 004403007) or equivalent

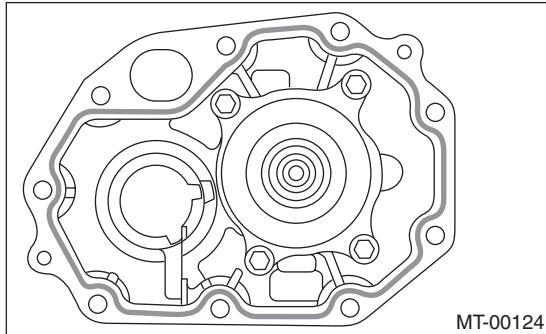

17) Install the extension case assembly to the transfer case.

Tightening torque:

40 N·m (4.1 kgf·m, 29.5 ft-lb)

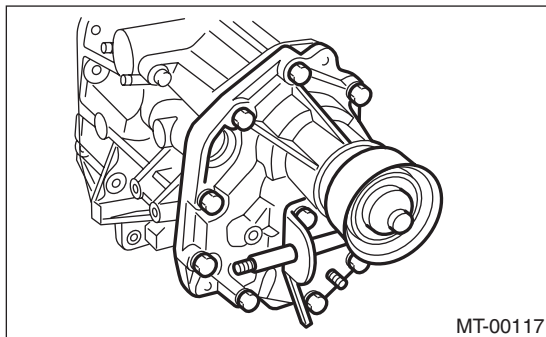

18) Attach the shifter arm to transfer case.

NOTE:

Apply gear oil to the oil seal lips.

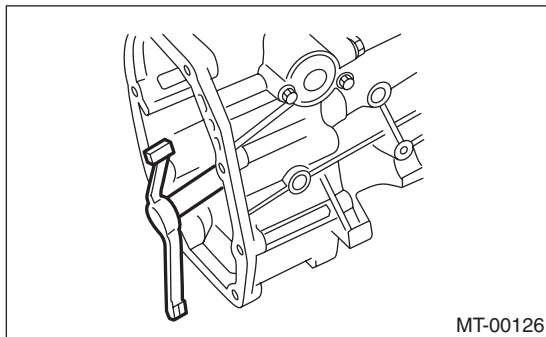

19) Attach the gasket.

NOTE:

Use a new gasket.

20) Hang the shifter arm on 3rd-4th fork rod.

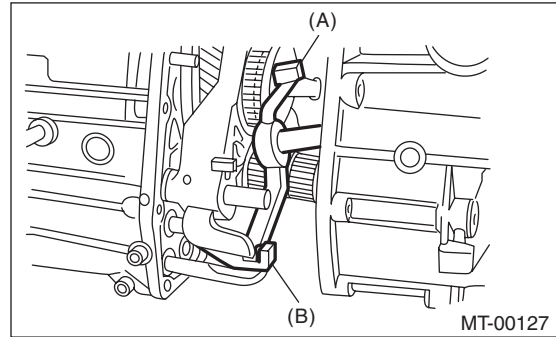

(A) Shifter arm

(B) 3rd-4th fork rod

21) Install the extension case assembly along with the transfer case to the transmission case.

Tightening torque:

24.5 N·m (2.5 kgf·m, 18.1 ft-lb)

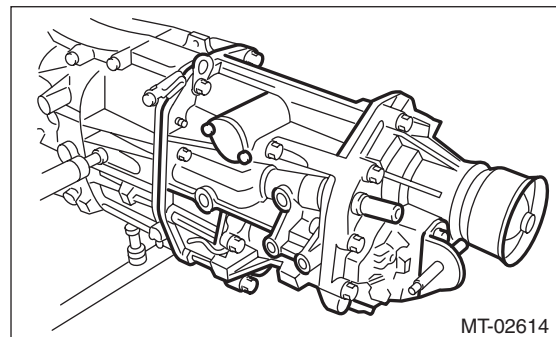

22) Install the back-up light switch and the neutral position switch. <Ref. to 5MT-35, INSTALLATION, Switches and Harness.>

23) Install the manual transmission assembly to the vehicle. <Ref. to 5MT-26, INSTALLATION, Manual Transmission Assembly.>

Transfer Case and Extension Case Assembly

MANUAL TRANSMISSION AND DIFFERENTIAL

C: DISASSEMBLY

1. TRANSFER CASE

- 1) Remove the reverse check sleeve assembly. <Ref. to 5MT-49, REMOVAL, Reverse Check Sleeve.>
- 2) Remove the oil guide.

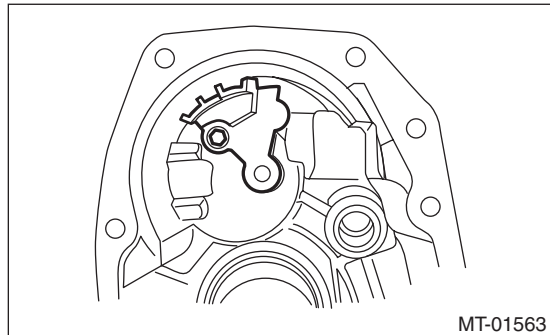

- 3) Remove the oil seal.
- 4) Set ST1, ST2 and transfer case to a press.

NOTE:

- Set the ST2 under ST1.
- Set the transfer case so that the hole for shifter arm is positioned vertically.

ST1 498267300 CYLINDER HEAD TABLE
ST2 498267200 CYLINDER HEAD TABLE

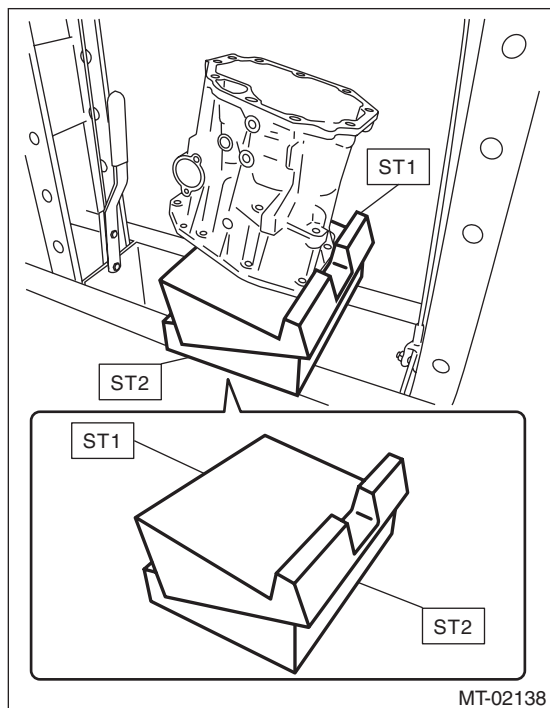

- 5) Using the round bar with diameter of 22 mm (0.87 in) or 23 mm (0.91 in), remove the roller bearing.

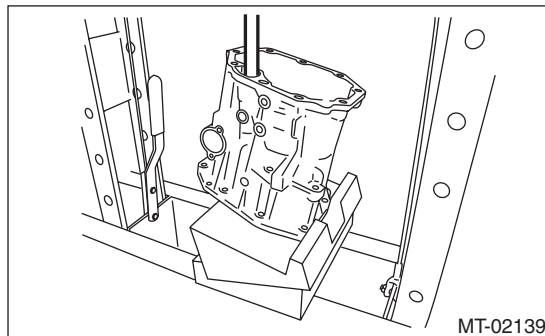

2. EXTENSION CASE

- 1) Remove the transfer drive gear assembly. <Ref. to 5MT-44, REMOVAL, Transfer Drive Gear.>
- 2) Remove the shift bracket.

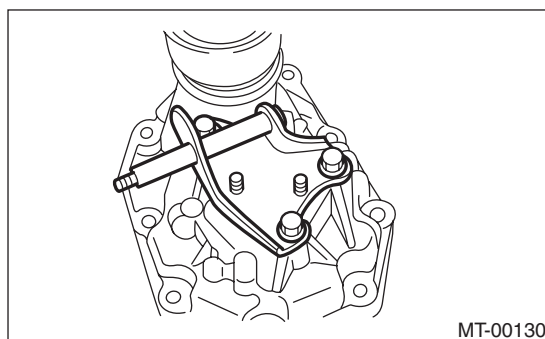

- 3) Remove the oil seal from the extension case. <Ref. to 5MT-32, Oil Seal.>

D: ASSEMBLY

1. EXTENSION CASE

- 1) Using the ST, install the oil seal to the extension case. <Ref. to 5MT-32, Oil Seal.>

NOTE:

Use a new oil seal.

- 2) Install the shift bracket to extension case.

Tightening torque:

24.5 N·m (2.5 kgf·m, 18.1 ft·lb)

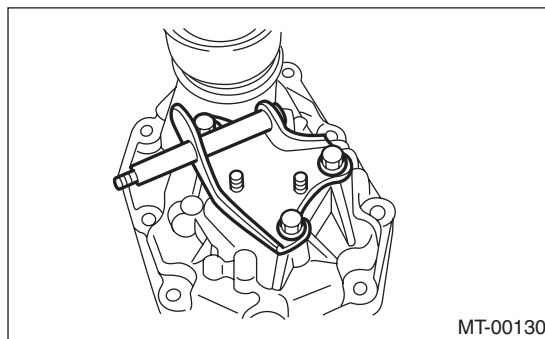

- 3) Install the transfer drive gear to the extension case. <Ref. to 5MT-44, INSTALLATION, Transfer Drive Gear.>

Transfer Case and Extension Case Assembly

MANUAL TRANSMISSION AND DIFFERENTIAL

2. TRANSFER CASE

1) Set the ST1, ST2, iron plate and the transfer case to the press.

NOTE:

- Set the ST2 under ST1.
- Set the transfer case so that the hole for shifter arm is positioned vertically.
- Insert the iron plate which is thicker than the exposed length of the transfer case knock pin between the ST and transfer case.
- Set the iron plate so that the transfer case knock pin does not ride on the iron plate.

ST1 498267300 CYLINDER HEAD TABLE

ST2 498267200 CYLINDER HEAD TABLE

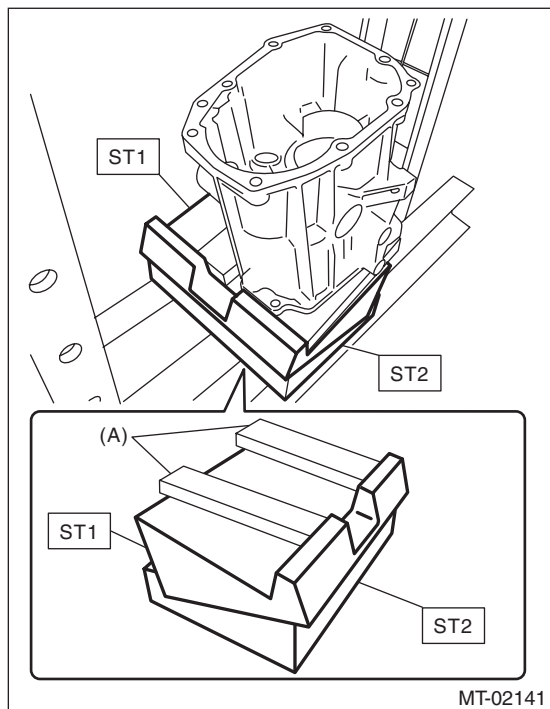

(A) Iron plate

2) Press-fit the roller bearing using the ST.

Press-fit depth of roller bearing:

A: 0 ± 0.2 mm (0 ± 0.01 in) from the end of transfer case

ST 899864100 REMOVER

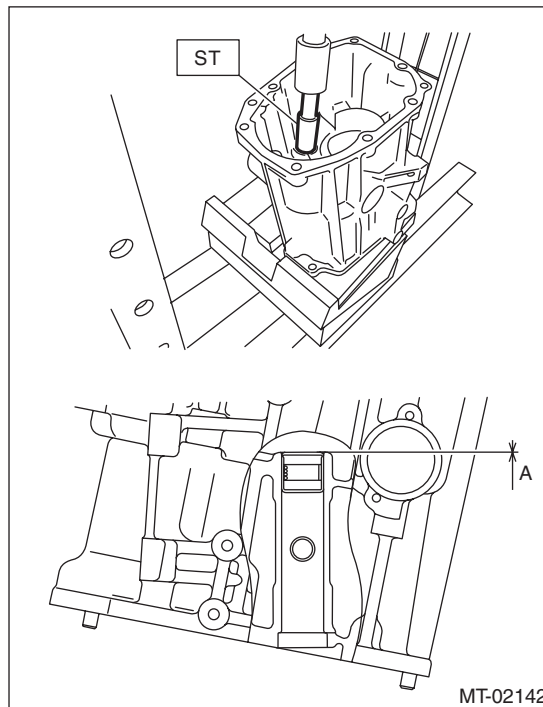

Transfer Case and Extension Case Assembly

MANUAL TRANSMISSION AND DIFFERENTIAL

3) Remove the iron plate, and turn over the transfer case.

NOTE:

Set the transfer case so that the hole for shifter arm is positioned vertically.

4) Press-fit the roller bearing using the ST.

Press-fit depth of roller bearing:

A: 0 ± 0.2 mm (0 ± 0.01 in) from the end of transfer case

ST 899864100 REMOVER

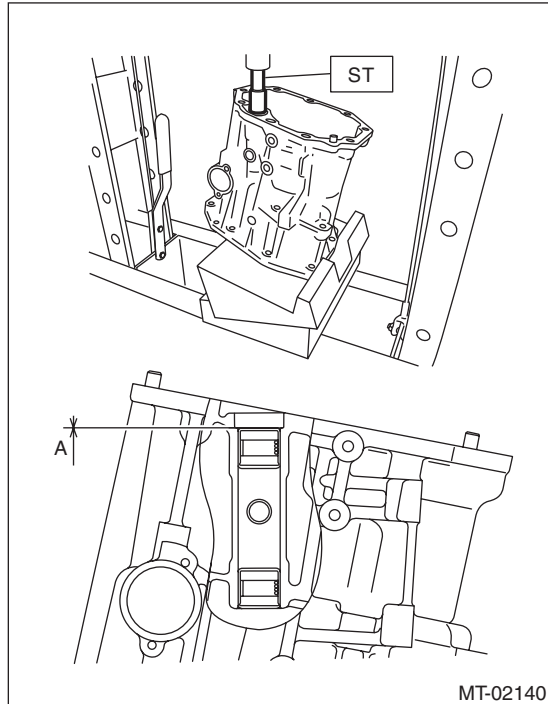

5) Install the shifter arm to the transfer case, and make sure that the shift arm moves smoothly.

6) Install the oil guide to the transfer case.

NOTE:

Use a new installing bolt.

Tightening torque:

6.4 N·m (0.7 kgf-m, 4.7 ft-lb)

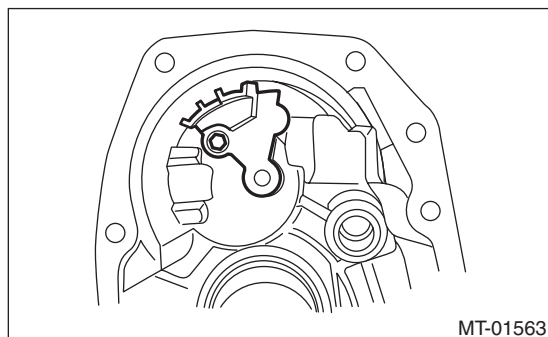

7) Install the reverse check sleeve assembly to the transfer case. <Ref. to 5MT-49, INSTALLATION, Reverse Check Sleeve.>

8) Install the oil seal.

NOTE:

Use a new oil seal.

Press-fit depth of oil seal:

A: 1 ± 0.2 mm (0.04 ± 0.01 in) from the end of transfer case

