

Transfer Driven Gear

MANUAL TRANSMISSION AND DIFFERENTIAL

11. Transfer Driven Gear

A: REMOVAL

- 1) Remove the manual transmission assembly from the vehicle. <Ref. to 5MT-23, REMOVAL, Manual Transmission Assembly.>
- 2) Remove the back-up light switch and the neutral position switch. <Ref. to 5MT-35, REMOVAL, Switches and Harness.>
- 3) Remove the transfer case together with the extension case assembly. <Ref. to 5MT-38, REMOVAL, Transfer Case and Extension Case Assembly.>
- 4) Remove the extension case assembly.
- 5) Remove the transfer driven gear.

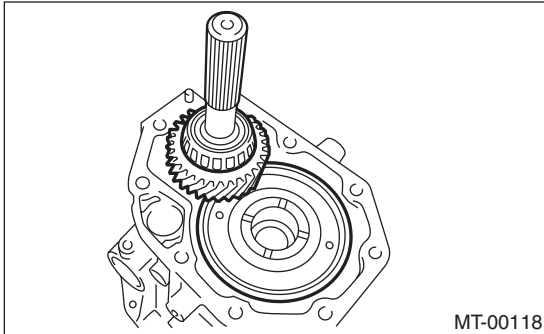

- 6) Remove bearing outer races from the extension case and transfer case.

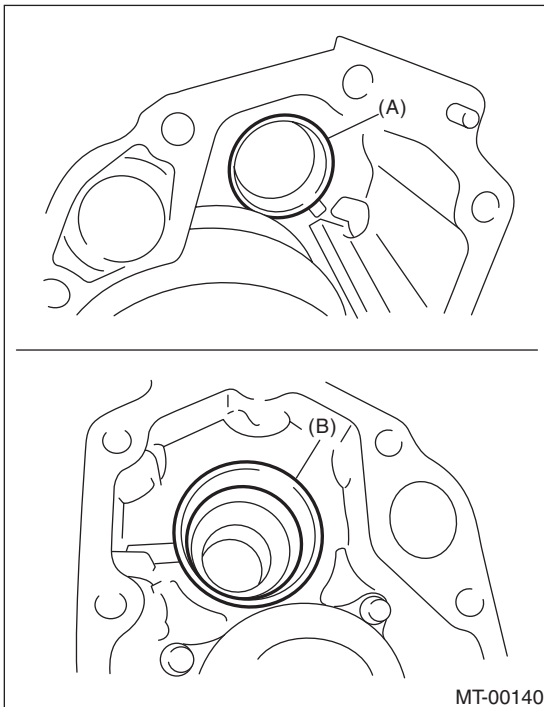

- (A) Bearing outer race (Transfer case side)
(B) Bearing outer race (Extension case side)

B: INSTALLATION

- 1) Install the bearing outer race to transfer case.

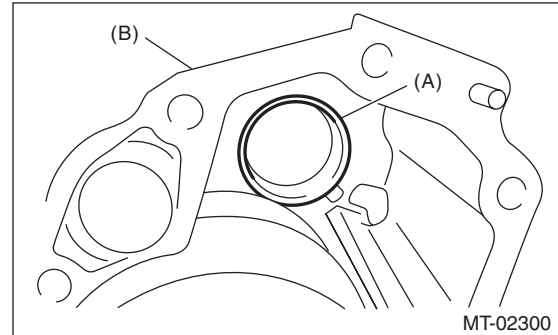

- (A) Bearing outer race
(B) Transfer case

- 2) Apply a coat of grease to the front roller bearing and rear roller bearing of the transfer driven gear.

Grease:

NICHIMOLY N-130 or equivalent

- 3) Install the transfer driven gear.

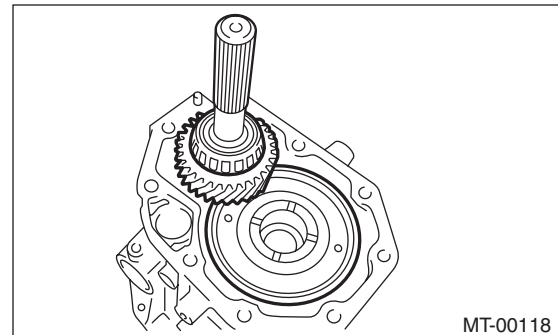

- 4) Select a thrust washer. <Ref. to 5MT-38, INSTALLATION, Transfer Case and Extension Case Assembly.>
- 5) Install the transfer case and the extension case assembly. <Ref. to 5MT-38, INSTALLATION, Transfer Case and Extension Case Assembly.>
- 6) Install the back-up light switch and the neutral position switch. <Ref. to 5MT-35, INSTALLATION, Switches and Harness.>
- 7) Install the manual transmission assembly to the vehicle. <Ref. to 5MT-26, INSTALLATION, Manual Transmission Assembly.>

Transfer Driven Gear

MANUAL TRANSMISSION AND DIFFERENTIAL

C: DISASSEMBLY

1) Using the ST, remove the roller bearing (extension case side).

ST 498077000 REMOVER

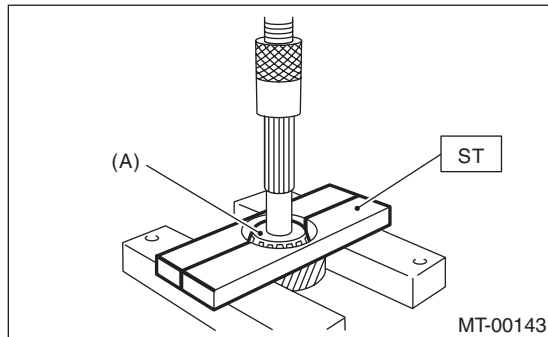

(A) Roller bearing

2) Using ST1 and ST2, remove the roller bearing (transfer case side).

ST1 498077000 REMOVER

ST2 899864100 REMOVER

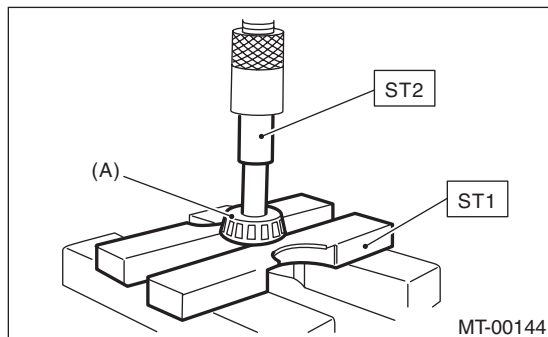

(A) Roller bearing

D: ASSEMBLY

1) Using ST, install the roller bearing (transfer case side).

ST 927640000 INSTALLER

CAUTION:

Do not apply a load in excess of 10 kN (1 ton, 1.1 US ton, 1.0 Imp ton).

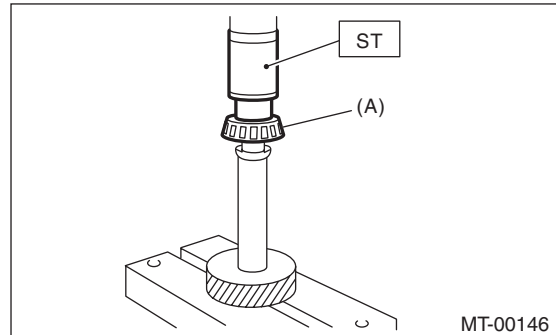

(A) Roller bearing

2) Using the ST, install the roller bearing (extension case side).

CAUTION:

Do not apply a load in excess of 10 kN (1 ton, 1.1 US ton, 1.0 Imp ton).

ST1 498175500 INSTALLER

ST2 899864100 REMOVER

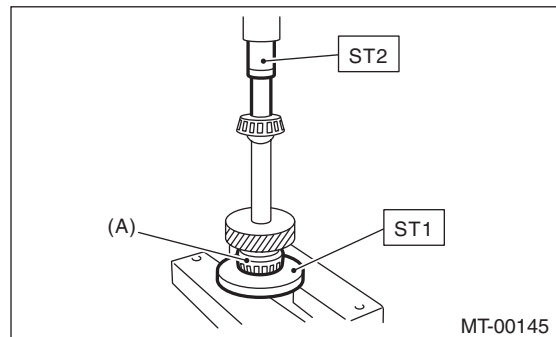

(A) Roller bearing

E: INSPECTION

1) Bearing

Replace the bearings in the following cases.

- In case of broken or rusty bearings
- In case of worn or damaged bearings
- When the bearings fail to turn smoothly or emit noise in rotation after gear oil lubrication.

2) Driven gear

If the tooth face of driven gear and the shaft are excessively broken or damaged, replace the driven gear.