

Transmission Case

MANUAL TRANSMISSION AND DIFFERENTIAL

14. Transmission Case

A: REMOVAL

- 1) Remove the manual transmission assembly from the vehicle. <Ref. to 5MT-23, REMOVAL, Manual Transmission Assembly.>
- 2) Remove the clutch release lever. <Ref. to CL-13, REMOVAL, Release Bearing and Lever.>
- 3) Remove the transfer case together with the extension case assembly. <Ref. to 5MT-38, REMOVAL, Transfer Case and Extension Case Assembly.>
- 4) Remove the bearing mounting bolt.

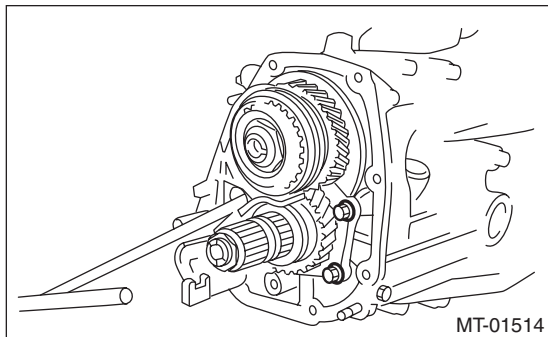

- 5) Remove the main shaft rear plate.

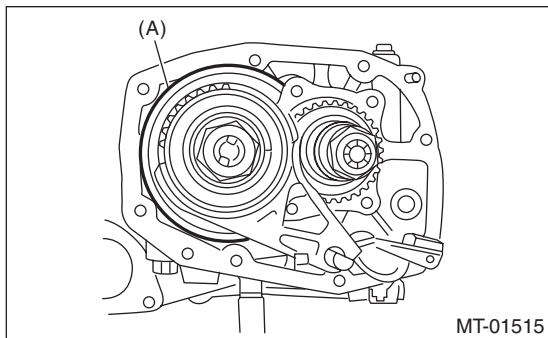

(A) Main shaft rear plate

- 6) Remove the bolts and nuts, and separate the transmission case into the right and left case.

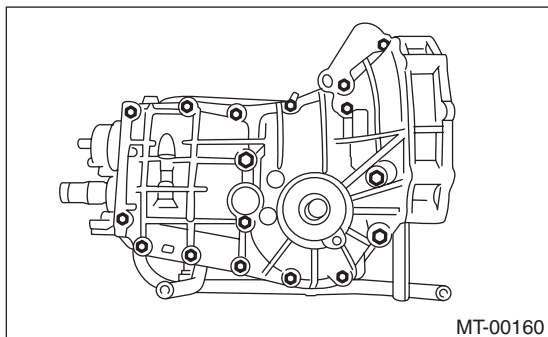

- 7) Remove the drive pinion shaft assembly.

NOTE:

Use a hammer handle, etc. to remove if too tight.

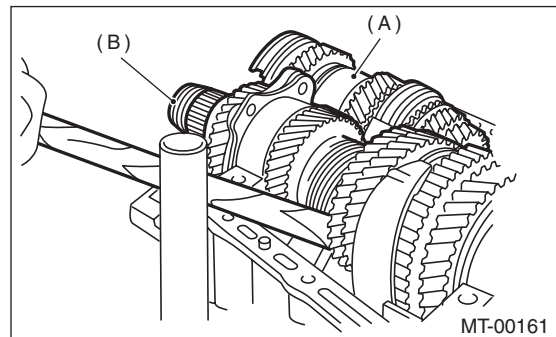

(A) Main shaft ASSY

(B) Drive pinion shaft ASSY

- 8) Remove the main shaft assembly.
- 9) Remove the front differential assembly.

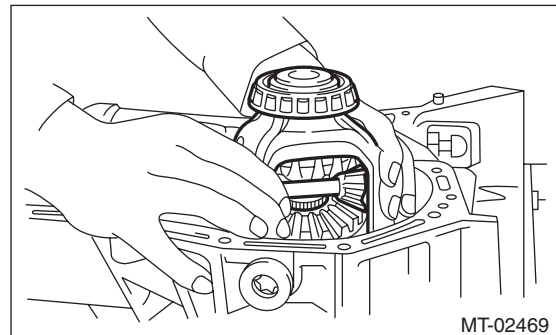

- 10) Remove the differential side retainers and bearing outer races on the left and right side. <Ref. to 5MT-71, REMOVAL, Front Differential Assembly.>

NOTE:

Do not confuse the right and left roller bearing outer races.

- 11) Remove the reverse idler gear. <Ref. to 5MT-81, REMOVAL, Shifter Fork and Rod.>
- 12) Remove the shifter fork and rod. <Ref. to 5MT-81, REMOVAL, Shifter Fork and Rod.>

B: INSTALLATION

- 1) Wipe off grease, oil and dust on the mating surfaces of transmission cases with cleaning solvent.
- 2) Install the reverse idler gear. <Ref. to 5MT-79, INSTALLATION, Reverse Idler Gear.>
- 3) Install the shifter fork and rod. <Ref. to 5MT-81, INSTALLATION, Shifter Fork and Rod.>
- 4) Select the drive pinion shim. <Ref. to 5MT-61, INSTALLATION, Drive Pinion Shaft Assembly.>
- 5) Install the bearing outer race to the transmission case LH side, and install the differential side retainer with the O-ring removed.
- 6) Install the front differential assembly.

Transmission Case

MANUAL TRANSMISSION AND DIFFERENTIAL

7) Install the main shaft assembly.

NOTE:

Align the needle bearing knock pin hole to the transmission case knock pin.

8) Install the selected drive pinion shims and drive pinion shaft assembly.

NOTE:

Align the roller bearing knock pin hole to the transmission case knock pin.

9) Align the left and right side of the transmission case, and tighten it with 17 mounting bolts.

NOTE:

- Insert bolts (11) and (16) from the LH side of the transmission case.
- Match the cases together so that the drive pinion shims are not caught between the cases.

Tightening torque:

8 mm bolt

25 N·m (2.5 kgf·m, 18.4 ft·lb)

★ **10 mm bolt**

39 N·m (4.0 kgf·m, 28.8 ft·lb)

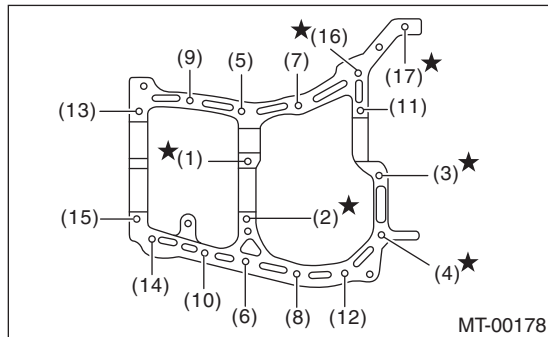

10) Install the bearing outer race to the RH side of the transmission case.

11) Tighten the bearing mounting bolts.

Tightening torque:

30 N·m (3.1 kgf·m, 22.1 ft·lb)

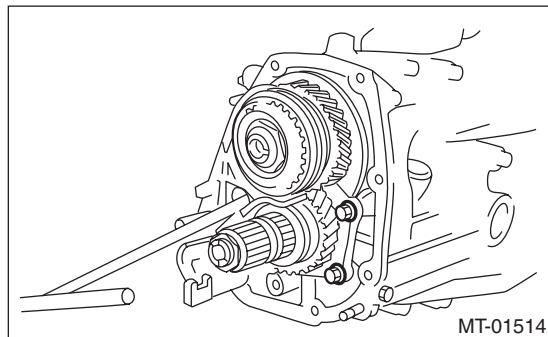

12) Adjust the backlash of the hypoid gear and the preload of the roller bearing.

(1) Attach the ST on drive pinion assembly.

ST 498427100 STOPPER

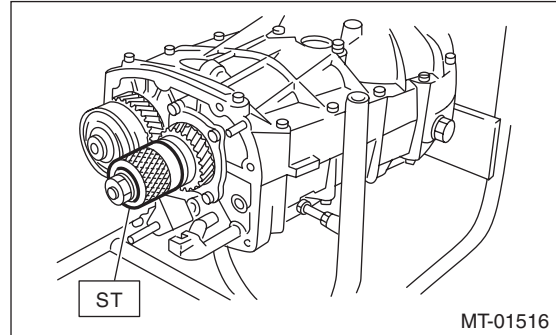

(2) Place the transmission with the LH side of case facing downward, and put ST1 on the bearing outer race.

(3) Screw the retainer assembly from the bottom into left case using ST2. Fit the ST3 on the main shaft. Shift the gear into 4th or 5th, and turn the shaft several times. Screw in the retainer while rotating the ST3 until a slight resistance is felt on ST2.

This is the contact point of the hypoid gear and the drive pinion shaft. Repeat the above sequence several times to ensure the contact point.

ST1 399780104

WEIGHT

ST2 18630AA010

WRENCH COMPL RETAINER

ST3 499927100

HANDLE

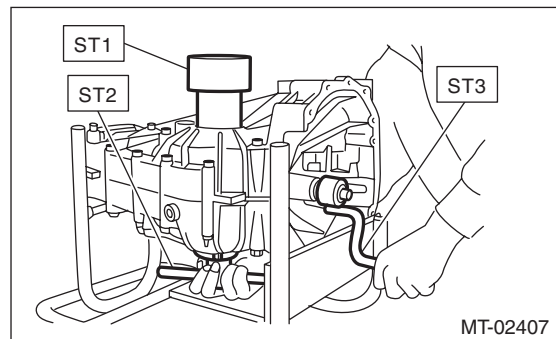

Transmission Case

MANUAL TRANSMISSION AND DIFFERENTIAL

(4) Remove the WEIGHT, and screw in the side retainer without the O-ring into the RH side of the transmission case, and stop at the point where a slight resistance is felt.

NOTE:

In this condition, the backlash between hypoid gear and drive pinion shaft is zero.

ST 18630AA010 WRENCH COMPL RETAINER

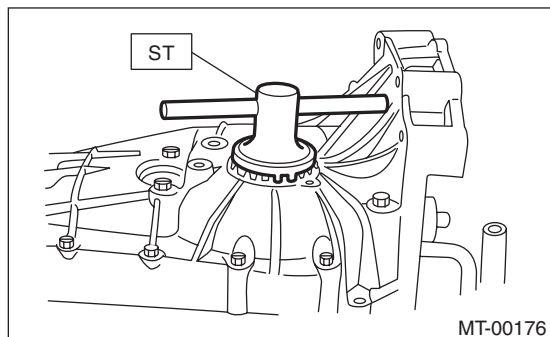

(5) Loosen the side retainer on the LH side of the transmission case by 3 notches, and turn the side retainer on the RH side of the transmission case by the same notches in order to apply backlash.

(6) Screw in the side retainer of the RH side of the transmission case additionally by 1 notch in order to apply preload on taper roller bearing.

(7) Tighten temporarily both the lock plates LH and RH, and put marks on both the side retainer and lock plate for later readjustment.

NOTE:

If it is hard to install the lock plates, reverse the sides and install them.

(8) Turn the main shaft several times while tapping around the retainer lightly with plastic hammer.

13) Inspect and adjust backlash and tooth contact of the hypoid gear. <Ref. to 5MT-75, INSPECTION, Front Differential Assembly.>

14) Separate the transmission case into left and right parts. <Ref. to 5MT-52, REMOVAL, Transmission Case.>

15) Check each shifter fork. <Ref. to 5MT-82, INSPECTION, Shifter Fork and Rod.>

16) Select a main shaft rear plate. <Ref. to 5MT-60, ADJUSTMENT, Main Shaft Assembly for Single-Range.>

17) Apply liquid gasket, then join the right side and left side of the case together.

Liquid gasket:

THREE BOND 1215 (Part No. 004403007) or equivalent

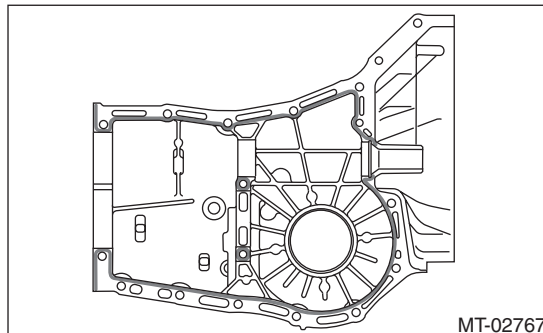

18) With brackets and clips as shown in the figure, tighten the seventeen bolts.

NOTE:

- Insert bolts (11) and (16) from the LH side of the transmission case.
- Match the cases together so that the drive pinion shims are not caught between the cases.

Tightening torque:

8 mm bolt

25 N·m (2.5 kgf-m, 18.4 ft-lb)

★ **10 mm bolt**

39 N·m (4.0 kgf-m, 28.8 ft-lb)

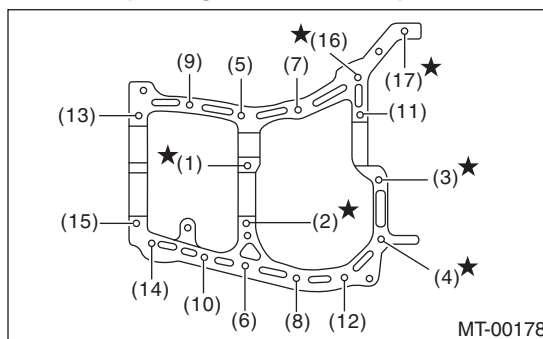

19) Tighten the bearing mounting bolts.

Tightening torque:

30 N·m (3.1 kgf-m, 22.1 ft-lb)

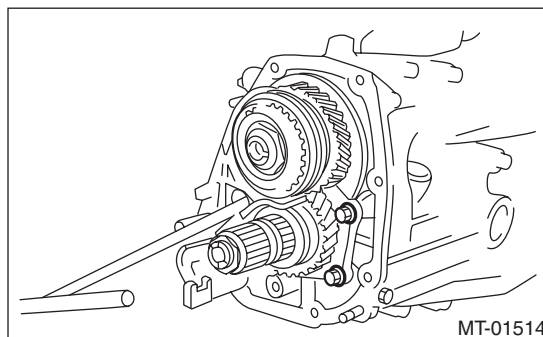

20) Remove the lock plate, and loosen the side retainer until the groove of the O-ring appears. Fit the O-ring into the groove and tighten the side retainer into the position where it was not loosened.

NOTE:

- When loosening the side retainer, record the number of the turns made.
- Perform this for both left and right side retainers.
- Use new O-rings.
- Apply gear oil to O-ring.

21) Install the lock plate.

Tightening torque:

T: 25 N·m (2.5 kgf-m, 18.4 ft-lb)

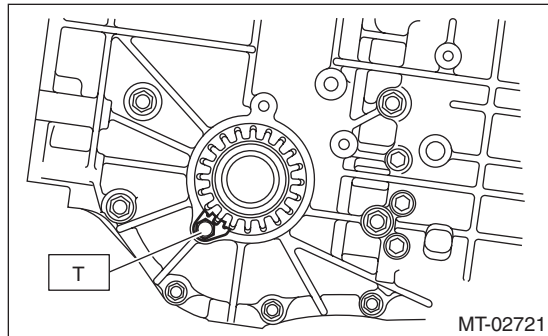

22) Install the transfer case together with the extension case assembly. <Ref. to 5MT-38, INSTALLATION, Transfer Case and Extension Case Assembly.>

23) Install the clutch release lever and bearing. <Ref. to CL-13, INSTALLATION, Release Bearing and Lever.>

24) Install the manual transmission assembly to the vehicle. <Ref. to 5MT-26, INSTALLATION, Manual Transmission Assembly.>

C: INSPECTION

Check the transmission case for cracks, damage, or oil leaks.