

Drive Pinion Shaft Assembly

MANUAL TRANSMISSION AND DIFFERENTIAL

16. Drive Pinion Shaft Assembly

A: REMOVAL

- 1) Remove the manual transmission assembly from the vehicle. <Ref. to 5MT-23, REMOVAL, Manual Transmission Assembly.>
- 2) Remove the transfer case together with the extension case assembly. <Ref. to 5MT-38, REMOVAL, Transfer Case and Extension Case Assembly.>
- 3) Remove the transmission case. <Ref. to 5MT-52, REMOVAL, Transmission Case.>
- 4) Remove the drive pinion shaft assembly.

NOTE:

Use a hammer handle, etc. to remove if too tight.

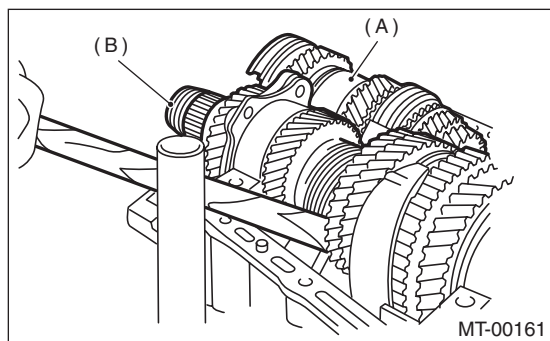

- (A) Main shaft ASSY
- (B) Drive pinion shaft ASSY

- 5) Remove the main shaft assembly. <Ref. to 5MT-56, REMOVAL, Main Shaft Assembly for Single-Range.>

B: INSTALLATION

- 1) Remove the front differential assembly.
- 2) Hypoid gear set match mark/No.: The number (A) on top of the drive pinion, and the number on the hypoid driven gear are set numbers for the two gears. Use a pair having the same numbers. The figure (B) below shows a number for shim adjustment. If no number is shown, the value is zero.

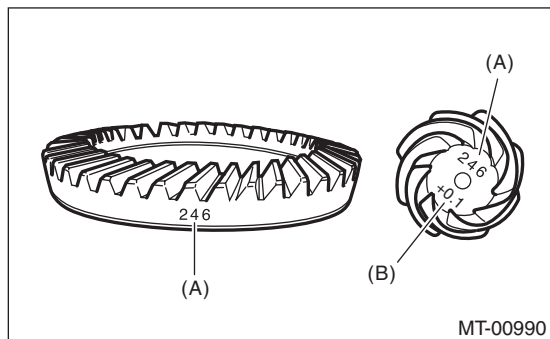

- (A) Set number
- (B) Number for shim adjustment

- 3) Place the drive pinion shaft assembly on transmission main case RH without shim and tighten the bearing mounting bolts.
- 4) Perform the adjustment of ST.

- (1) Loosen the two bolts and adjust so that the scale indicates 0.5 correctly when the plate end and the scale end are on the same level.

ST 499917500 DRIVE PINION GAUGE ASSY

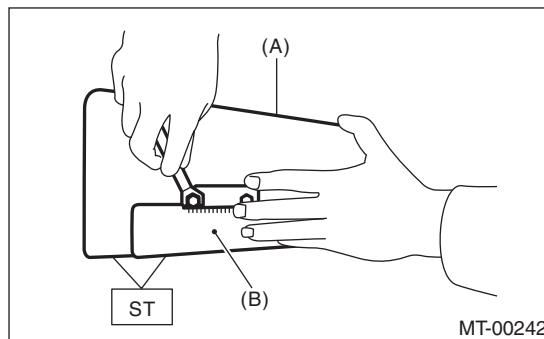

- (A) Plate
- (B) Scale

- (2) Tighten the two bolts.

- 5) Position the ST by inserting the knock pin of ST into the knock hole of transmission case.

ST 499917500 DRIVE PINION GAUGE ASSY

- 6) Slide the drive pinion gauge scale with finger tip and read the value at the point where it matches with the end face of drive pinion.

ST 499917500 DRIVE PINION GAUGE ASSY

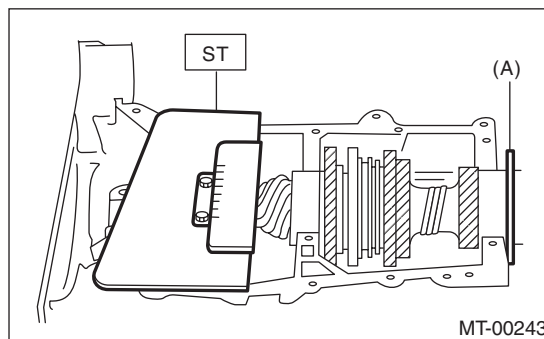

- (A) Adjust the clearance to zero without shim.

- 7) The thickness of shim shall be determined by adding the value indicated on drive pinion to the value indicated on the ST. (Add if the number on drive pinion is prefixed by +, and subtract if the number is prefixed by -.)

ST 499917500 DRIVE PINION GAUGE ASSY

Drive Pinion Shaft Assembly

MANUAL TRANSMISSION AND DIFFERENTIAL

8) Select one to three shims in the following table for the value determined as described above, and take the shim(s) which thickness is closest to the said value.

Drive pinion shim	
Part No.	Thickness mm (in)
32295AA031	0.150 (0.0059)
32295AA041	0.175 (0.0069)
32295AA051	0.200 (0.0079)
32295AA061	0.225 (0.0089)
32295AA071	0.250 (0.0098)
32295AA081	0.275 (0.0108)
32295AA091	0.300 (0.0118)
32295AA101	0.500 (0.0197)

9) Install the front differential assembly. <Ref. to 5MT-71, INSTALLATION, Front Differential Assembly.>

10) Fit the transmission case knock pin to the knock pin hole of the roller bearing and install the drive pinion shaft assembly.

11) Install the main shaft assembly. <Ref. to 5MT-56, INSTALLATION, Main Shaft Assembly for Single-Range.>

12) Check each shifter fork. <Ref. to 5MT-82, INSPECTION, Shifter Fork and Rod.>

13) Install the transmission case. <Ref. to 5MT-52, INSTALLATION, Transmission Case.>

14) Install the transfer case together with the extension case assembly. <Ref. to 5MT-38, INSTALLATION, Transfer Case and Extension Case Assembly.>

15) Install the manual transmission assembly to the vehicle. <Ref. to 5MT-26, INSTALLATION, Manual Transmission Assembly.>

C: DISASSEMBLY

NOTE:

Attach a cloth to the end of driven shaft (on the frictional side of the thrust needle bearing) to prevent damage during disassembly or reassembly.

1) Flatten the tab of the lock nut. Remove the lock nut with ST1, ST2 and ST3.

ST1 899884100 HOLDER

ST2 498427100 STOPPER

ST3 899988608 SOCKET WRENCH (27)

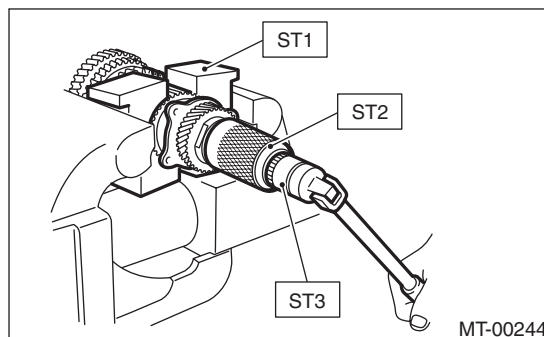

2) Draw out the drive pinion shaft from driven shaft. Remove the differential bevel gear sleeve, adjusting washer No. 1, adjusting washer No. 2, thrust bearing, needle bearing and drive pinion collar.

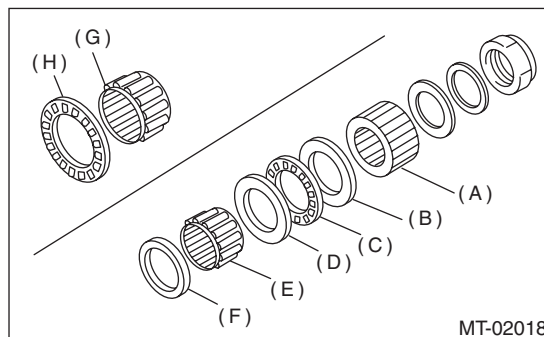

- (A) Differential bevel gear sleeve
- (B) Adjusting washer No. 1 (25 × 37.5 × t)
- (C) Thrust bearing (25 × 37.5 × 3)
- (D) Adjusting washer No. 2 (25 × 37.5 × t)
- (E) Needle bearing (25 × 30 × 20)
- (F) Drive pinion collar
- (G) Needle bearing (30 × 37 × 23)
- (H) Thrust bearing (33 × 50 × 3)

Drive Pinion Shaft Assembly

MANUAL TRANSMISSION AND DIFFERENTIAL

3) Remove the roller bearing and washer using ST and a press.

ST 498077000 REMOVER

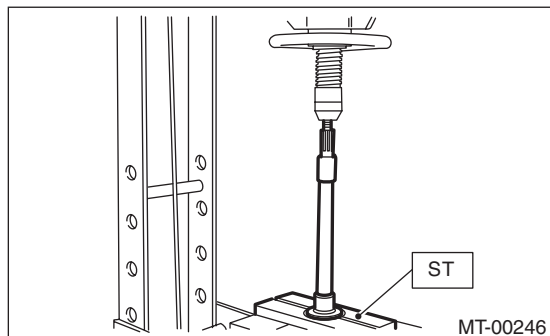

4) Flatten the tab of the lock nut. Remove the lock nut and lock washer using ST1 and ST2.

ST1 499987300 SOCKET WRENCH (50)
ST2 899884100 HOLDER

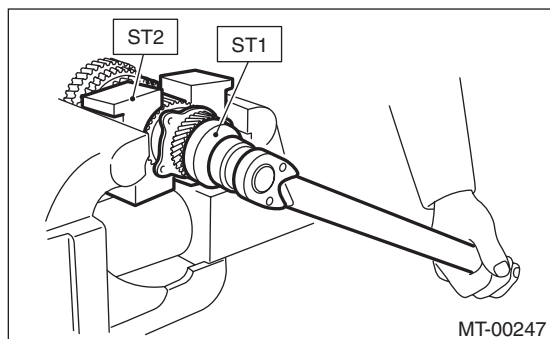

5) Remove the 5th driven gear using ST.

ST 499857000 5TH DRIVEN GEAR REMO-
VER

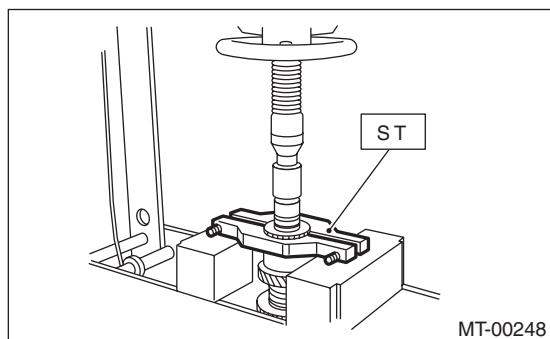

6) Remove the woodruff key.

7) Remove the double taper roller bearing and 3rd-4th driven gear using ST1 and ST2.

ST1 499757002 INSTALLER
ST2 899714110 REMOVER

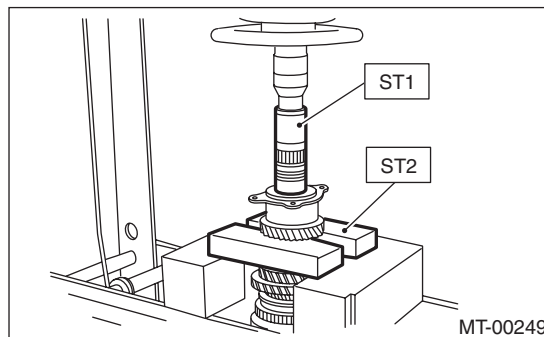

8) Remove the key.

9) Remove the 2nd driven gear, inner baulk ring, synchro cone and outer baulk ring.

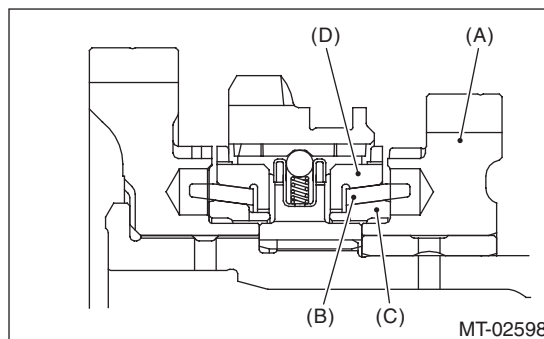

- (A) 2nd driven gear
- (B) Synchro cone
- (C) Inner baulk ring
- (D) Outer baulk ring

10) Remove the 1st driven gear, inner baulk ring, synchro cone, outer baulk ring, 2nd gear bushing and gear & hub assembly using ST1 and ST2.

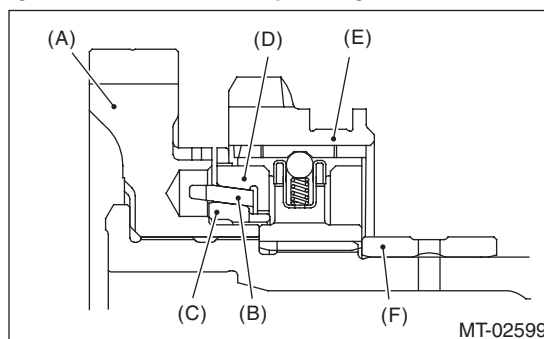

- (A) 1st driven gear
- (B) Synchro cone
- (C) Inner baulk ring
- (D) Outer baulk ring
- (E) Gear & hub
- (F) 2nd gear bushing

Drive Pinion Shaft Assembly

MANUAL TRANSMISSION AND DIFFERENTIAL

NOTE:

If necessary, use a new gear and hub assembly as a set, when replacing the gear or hub. Because these must engage at the specified point, avoid disassembly as much as possible. If it must be disassembled, mark the engaging point on the spline beforehand.

ST1 499757002 INSTALLER

ST2 899714110 REMOVER

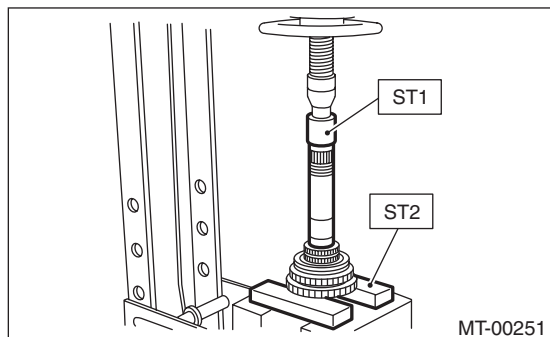

D: ASSEMBLY

1) Install the sleeve and the gear and hub assembly by matching the alignment marks.

NOTE:

- Make sure that there is no large clearance at both sides of ball detent after assembly.

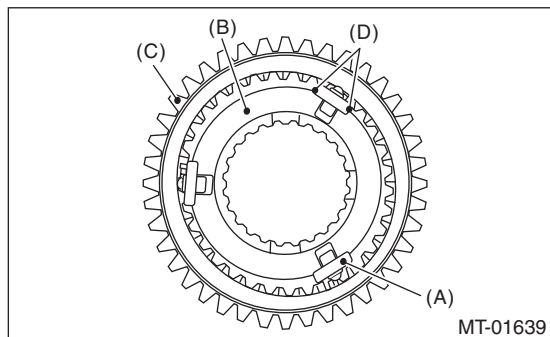

- (A) Ball detent
- (B) 1st-2nd synchronizer hub
- (C) Reverse driven gear
- (D) There is no large clearance at this part.

- Use the new gear & hub assembly, if replacing the gear or hub.

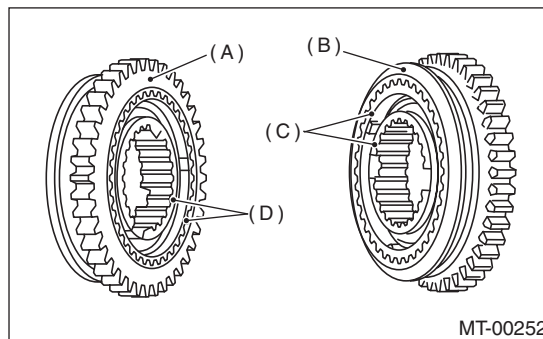

- (A) 1st gear side
- (B) 2nd gear side
- (C) Flush surface
- (D) Stepped surface

2) Install the 1st driven gear, inner baulk ring, synchro cone, outer baulk ring, and gear & hub assembly onto driven shaft.

NOTE:

- Install the gear & hub assembly in the proper position while paying attention to the installing direction.
- Align the baulk ring and gear & hub assembly with the key groove.

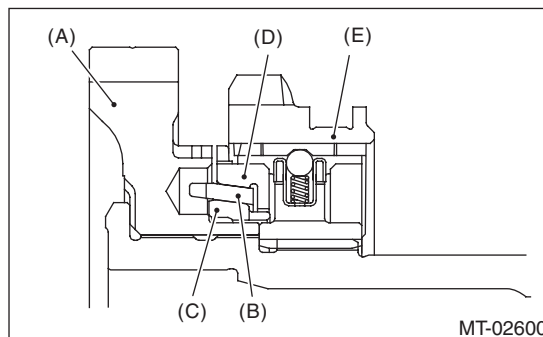

- (A) 1st driven gear
- (B) Synchro cone
- (C) Inner baulk ring
- (D) Outer baulk ring
- (E) Gear & hub

Drive Pinion Shaft Assembly

MANUAL TRANSMISSION AND DIFFERENTIAL

3) Install the 2nd driven gear bushing onto driven shaft using ST1, ST2 and a press.

CAUTION:

Do not apply a load in excess of 10 kN (1 ton, 1.1 US ton, 1.0 Imp ton).

NOTE:

- Attach a cloth to the end of the driven shaft to prevent damage.
- When press fitting, align the oil holes of the shaft and bushing.

ST1 499277200 INSTALLER

ST2 499587000 INSTALLER

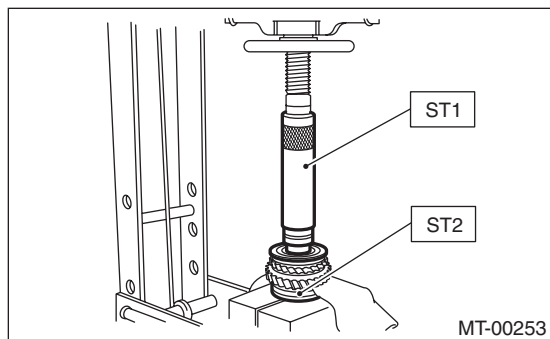

4) Install the 2nd driven gear, inner baulk ring, synchro cone and outer baulk ring, and insert them onto driven shaft.

NOTE:

Align the groove in baulk ring with the insert.

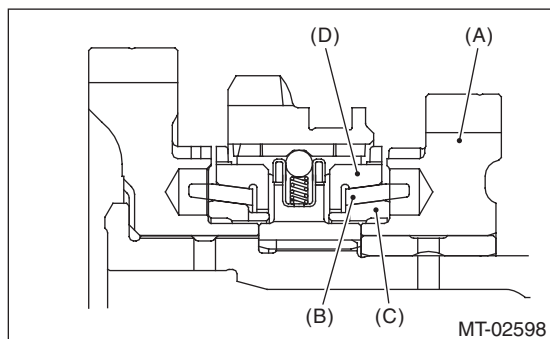

(A) 2nd driven gear

(B) Synchro cone

(C) Inner baulk ring

(D) Outer baulk ring

5) After installing key onto the driven shaft, install the 3rd-4th driven gear using ST1, ST2 and a press.

CAUTION:

Do not apply a load in excess of 10 kN (1 ton, 1.1 US ton, 1.0 Imp ton).

ST1 499277200 INSTALLER

ST2 499587000 INSTALLER

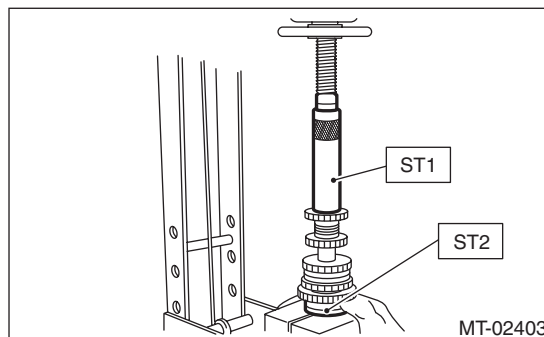

6) Install a set of double taper roller bearings onto the driven shaft using ST1, ST2 and a press.

CAUTION:

Do not apply a load in excess of 10 kN (1 ton, 1.1 US ton, 1.0 Imp ton).

NOTE:

Use a new double taper roller bearing.

ST1 499277200 INSTALLER

ST2 499587000 INSTALLER

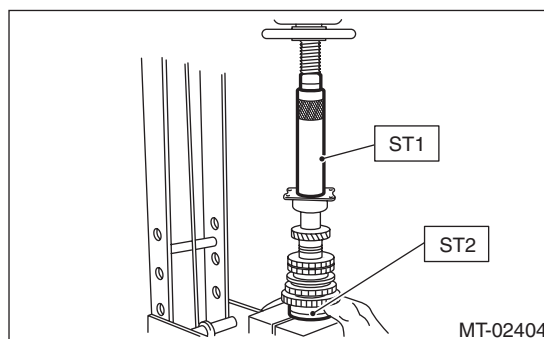

Drive Pinion Shaft Assembly

MANUAL TRANSMISSION AND DIFFERENTIAL

7) Position the woodruff key in groove of the rear of driven shaft. Install the 5th driven gear to the driven shaft using ST1, ST2 and a press.

CAUTION:

Do not apply a load in excess of 10 kN (1 ton, 1.1 US ton, 1.0 Imp ton).

ST1 499277200 INSTALLER

ST2 499587000 INSTALLER

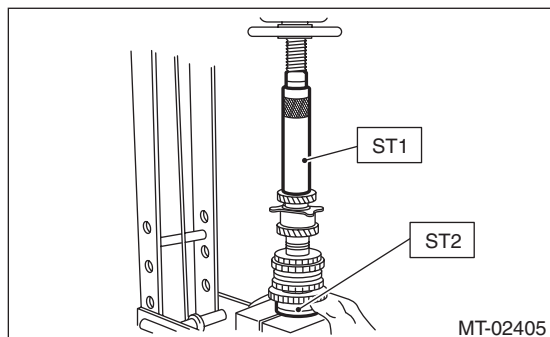

8) Install the lock washer. Tighten the lock nuts to the specified torque using ST1 and ST2.

NOTE:

- Use new lock nuts and lock washers.
- Make sure the lock washer is installed in the proper direction.

ST1 499987300 SOCKET WRENCH (50)

ST2 899884100 HOLDER

Tightening torque:

260 N·m (26.5 kgf·m, 191.8 ft·lb)

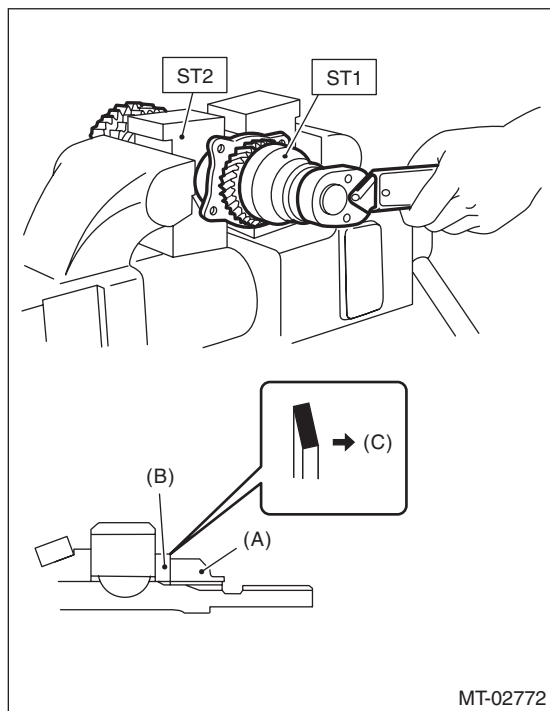

- (A) Lock nut
- (B) Lock washer
- (C) Nut side

9) Using a spring scale, check that starting torque of the double taper roller bearing is 0.1 to 1.5 N (0.01 to 0.15 kgf, 0.02 to 0.34 lbf).

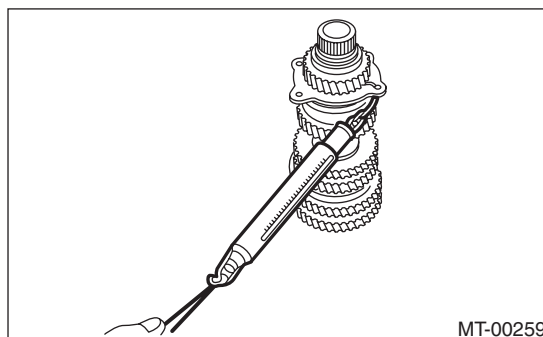

10) Crimp the lock nut at two locations so that the dimension (B) becomes 41.1 mm (1.62 in) or less.

CAUTION:

When crimping the lock nut, be careful not to crack it.

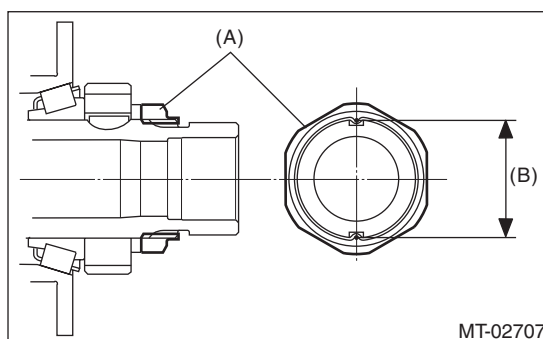

- (A) Lock nut
- (B) Outer dimension after crimping

11) Install the roller bearing onto the drive pinion shaft.

NOTE:

- Use a new roller bearing.
- When installing the roller bearing, direct the knock pin hole of outer race toward rear.

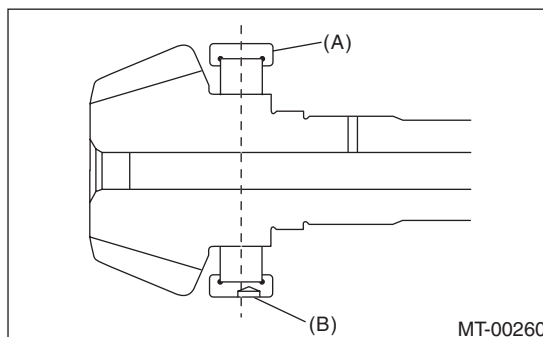

- (A) Roller bearing
- (B) Knock pin hole

Drive Pinion Shaft Assembly

MANUAL TRANSMISSION AND DIFFERENTIAL

12) Install the washer using ST1, ST2 and a press.

CAUTION:

Do not apply a load in excess of 10 kN (1 ton, 1.1 US ton, 1.0 Imp ton).

ST1 499277100 BUSHING 1-2 INSTALLER

ST2 499277200 INSTALLER

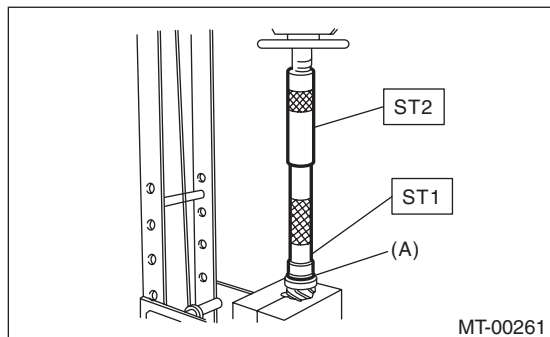

(A) Washer

13) Install the thrust bearing and needle bearing and install the driven shaft assembly.

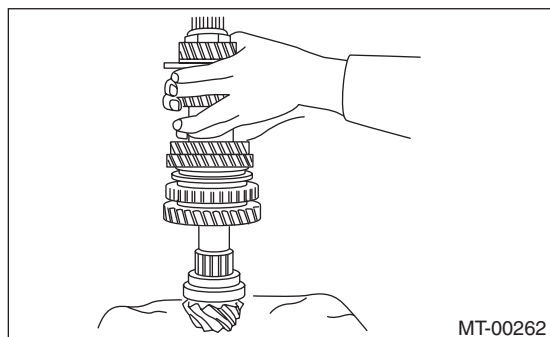

14) Install the drive pinion collar, needle bearing, adjusting washer No. 2, thrust bearing, adjusting washer No. 1 and differential bevel gear sleeve in this order.

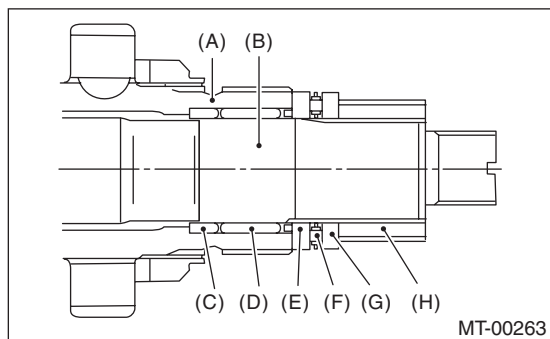

- (A) Driven shaft
- (B) Drive shaft
- (C) Drive pinion collar
- (D) Needle bearing (25 × 30 × 20)
- (E) Adjusting washer No. 2 (25 × 36 × t)
- (F) Thrust bearing (25 × 37.5 × 3)
- (G) Adjusting washer No. 1 (25 × 36 × t)
- (H) Differential bevel gear sleeve

15) Adjust the thrust bearing preload. <Ref. to 5MT-68, THRUST BEARING PRELOAD, ADJUSTMENT, Drive Pinion Shaft Assembly.>

E: INSPECTION

Disassembled parts should be washed with cleaning solvent first, then inspected carefully.

1) Bearing

Replace the bearings in the following cases.

- When the bearing balls, outer races and inner races are broken or rusty.
- When the bearing is worn.
- When the bearings fail to turn smoothly or emit noise in rotation after gear oil lubrication.
- The ball bearing on the rear side of the drive pinion shaft should be checked for smooth rotation before the drive pinion shaft assembly is disassembled. In this case, because a preload is working on the bearing, its rotation feels like it is slightly dragging unlike other bearings.

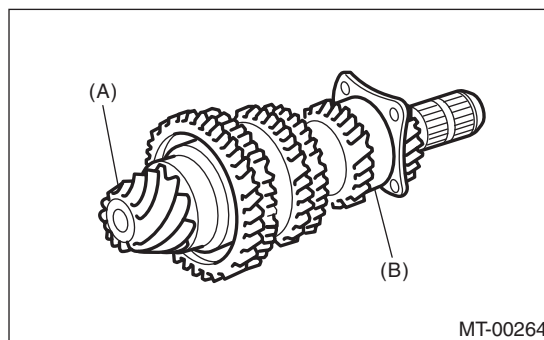

- (A) Drive pinion shaft
- (B) Ball bearing

- When bearing has other defects.

2) Bushing (each gear)

Replace the bushing in following cases.

- When the sliding surface is damaged or abnormally worn.
- When the inner wall is abnormally worn.

3) Gear

Replace gears in the following cases.

- Replace the gear with new part if its tooth surfaces are broken, damaged or excessively worn.
- Correct or replace if the contact surface between the cone and baulk ring is rough or damaged.
- Correct or replace if the inner surface or end face is damaged.

Drive Pinion Shaft Assembly

MANUAL TRANSMISSION AND DIFFERENTIAL

4) Baulk ring, synchro cone

Replace the baulk ring and synchro cone in the following cases.

- When the inner surface and end face are damaged.
- When the baulk ring inner surface is abnormally or partially worn down.
- When the contact surface of the baulk ring insert section is cracked or abnormally worn.
- If the gap between the end faces of the baulk ring and the gear splined part is excessively small, check the clearance (A) while pressing the ring against the cone.

Clearance (A):

0.5 mm (0.020 in) or more

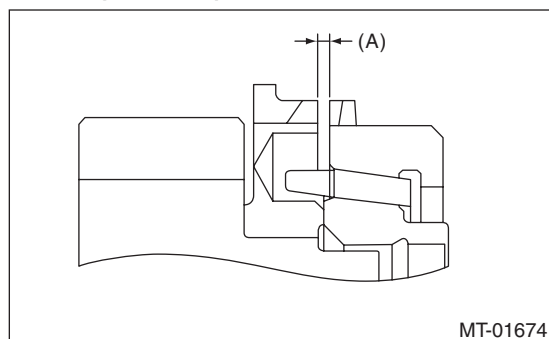

- Apply gear oil to the cone of the gear and while press-fitting the baulk ring, check there is no rotation in the circumferential direction.

5) Coupling sleeve and synchronizer hub

- Check the slipping condition of the coupling sleeve.

- Check the splines on the coupling sleeve and synchronizer hub for wear.

6) Ball detent

Replace the ball detent if deformed, excessively worn or defective in any way.

F: ADJUSTMENT

1. THRUST BEARING PRELOAD

- 1) Select a suitable adjusting washer No. 1 so that dimension (H) will be zero in a visual check. Position the washer (18.3 × 30 × t) and lock washer (18 × 30 × 2) and attach the lock nut.

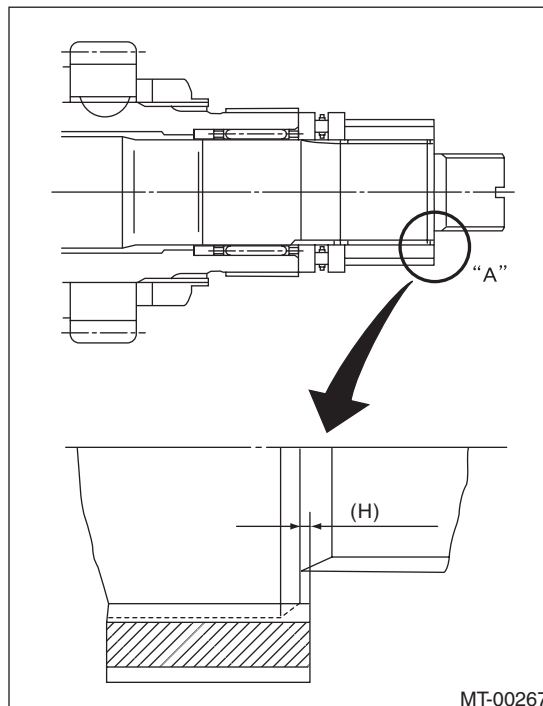

Drive Pinion Shaft Assembly

MANUAL TRANSMISSION AND DIFFERENTIAL

2) Using the ST1, ST2 and ST3, tighten the new lock nut to the specified torque.

NOTE:

- Use new lock nuts and lock washers.
- Make sure the lock washer is installed in the proper direction.

ST1 899884100 HOLDER
 ST2 498427100 STOPPER
 ST3 899988608 SOCKET WRENCH (27)

Tightening torque:

120 N·m (12.2 kgf·m, 88.5 ft·lb)

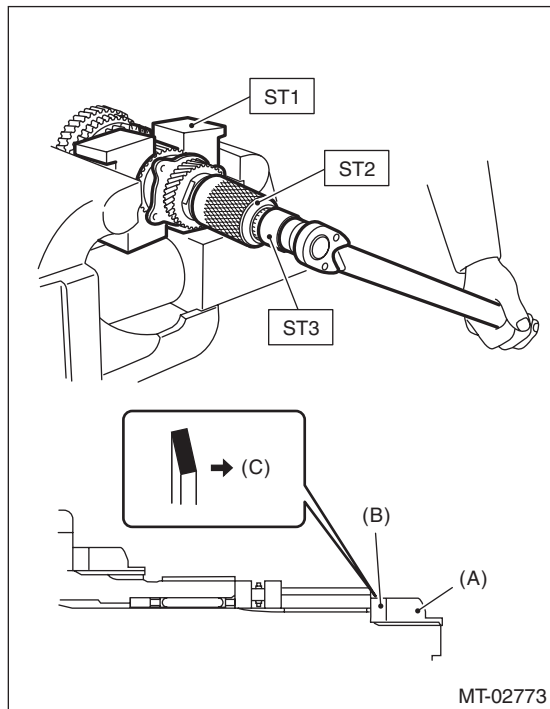

- (A) Lock nut
- (B) Lock washer
- (C) Nut side

3) After removing the ST2, measure the starting torque using torque driver.

ST1 899884100 HOLDER
 ST3 899988608 SOCKET WRENCH (27)

Starting torque:

0.3 — 0.8 N·m (0.03 — 0.08 kgf·m, 0.22 — 0.59 ft·lb)

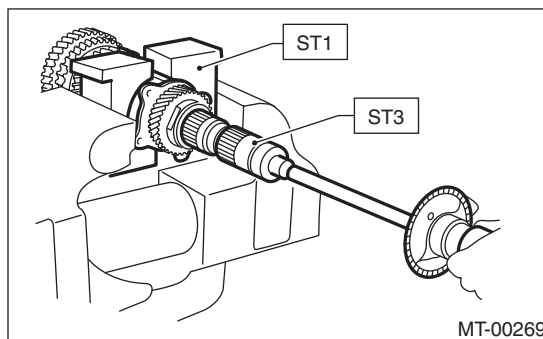

4) If the starting torque is not within the specified limit, select new adjusting washer No. 1 and re-check starting torque.

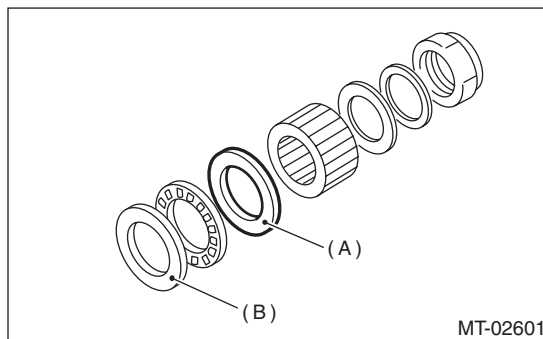

- (A) Adjusting washer No. 1
- (B) Adjusting washer No. 2

Adjusting washer No. 1	
Part No.	Thickness mm (in)
803025051	3.925 (0.1545)
803025052	3.950 (0.1555)
803025053	3.975 (0.1565)
803025054	4.000 (0.1575)
803025055	4.025 (0.1585)
803025056	4.050 (0.1594)
803025057	4.075 (0.1604)

Drive Pinion Shaft Assembly

MANUAL TRANSMISSION AND DIFFERENTIAL

5) If the specified starting torque cannot be obtained by the selection of adjusting washer No. 1, select adjusting washer No. 2 from the list below. Repeat steps 1) through 4) to adjust starting torque.

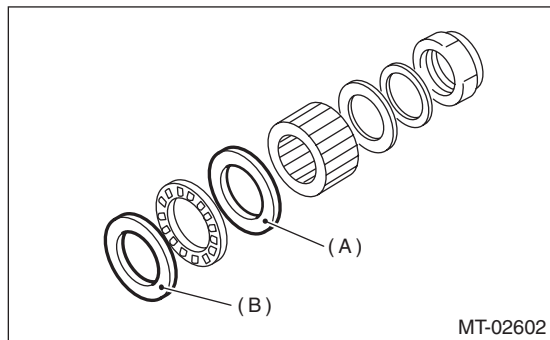

(A) Adjusting washer No. 1

(B) Adjusting washer No. 2

Starting torque	Dimension H	Adjusting washer No. 2
Low	Small	Select thicker one.
High	Large	Select thinner one.

Adjusting washer No. 2	
Part No.	Thickness mm (in)
803025059	3.850 (0.1516)
803025054	4.000 (0.1575)
803025058	4.150 (0.1634)

6) Recheck that the starting torque is within the specified range, then crimp the lock nut at four positions.

CAUTION:

Do not allow the lock nut to be cracked during crimping operation.