

Front Ball Joint

FRONT SUSPENSION

6. Front Ball Joint

A: REMOVAL

- 1) Lift up the vehicle, and then remove the front wheels.
- 2) Remove the clamp - stabilizer bushing on the left and right sides.

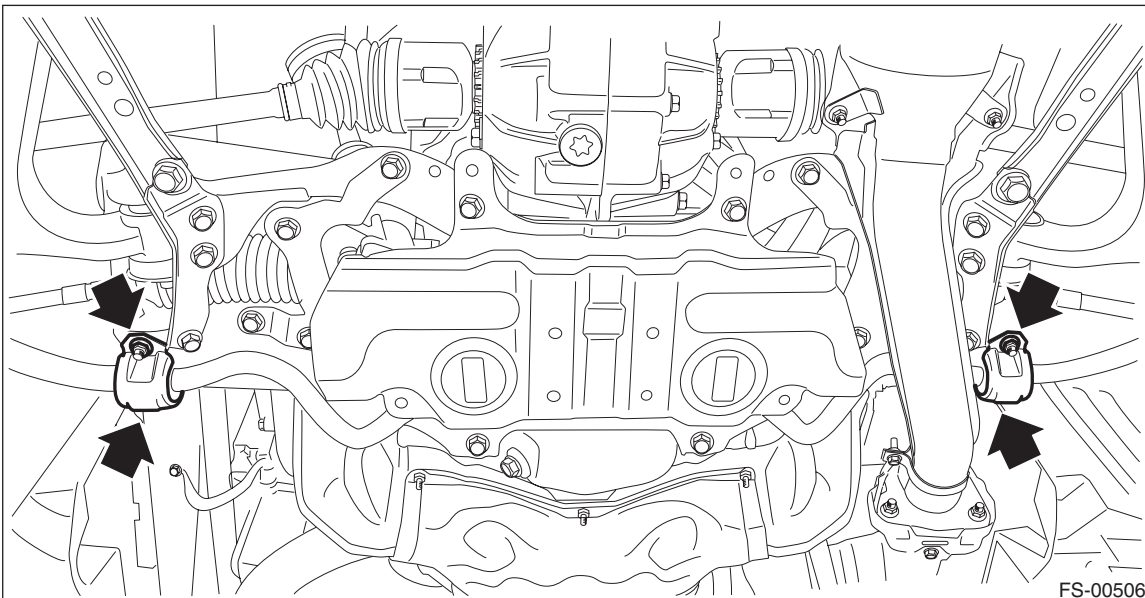

- 3) Remove the ball joint assembly.
 - (1) Pull out the cotter pin (a), and remove the castle nut (b).
 - (2) Lower the front arm assembly, and remove the ball stud.
 - (3) Remove the bolt from the housing assembly - front axle.

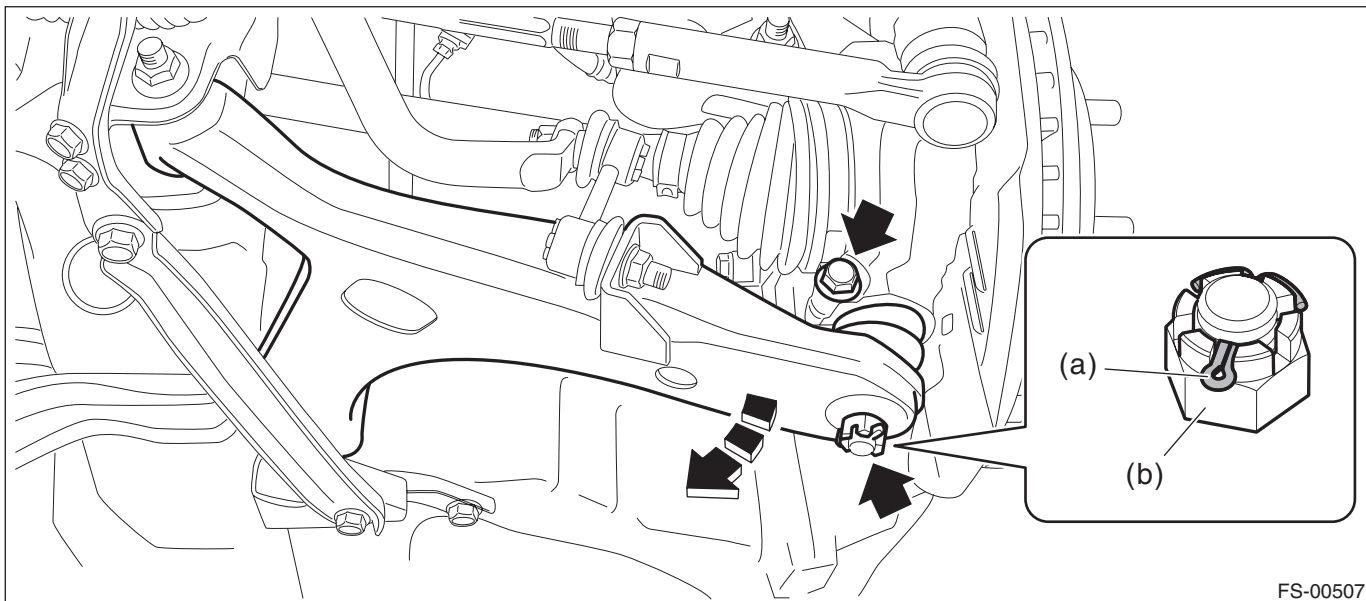

- (4) Extract the ball joint assembly from the housing assembly - front axle.

B: INSTALLATION

1) Install the ball joint assembly to the housing assembly - front axle.

CAUTION:

- Do not apply grease to the tapered portion of ball stud.
- Before tightening, make sure the bottom surface of the housing assembly - front axle and the stepped section of ball joint are in contact.

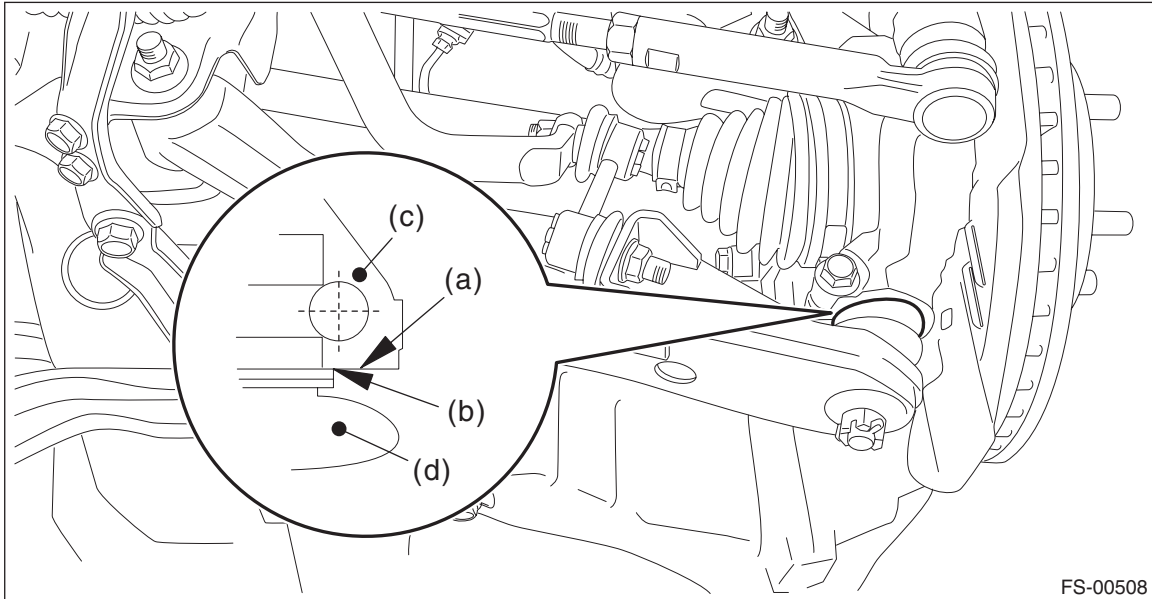

- (a) Bottom surface of housing ASSY - front axle (c) Housing ASSY - front axle (d) Ball joint ASSY
 (b) Raised section of ball joint

Tightening torque:

50 N·m (5.10 kgf-m, 36.9 ft-lb)

2) Install the ball joint assembly to the front arm assembly.

- (1) Connect the ball joint assembly to the front arm assembly.

Tightening torque:

39 N·m (3.98 kgf-m, 28.8 ft-lb)

- (2) Retighten the castle nut further up to 60° until the hole in the ball stud is aligned with a slot in castle nut.
 (3) Insert a new cotter pin and bend it around the castle nut.

Front Ball Joint

FRONT SUSPENSION

3) Install the clamp - stabilizer bushing.

CAUTION:

Install the clamp - stabilizer bushing with the arrow mark facing the front of the vehicle.

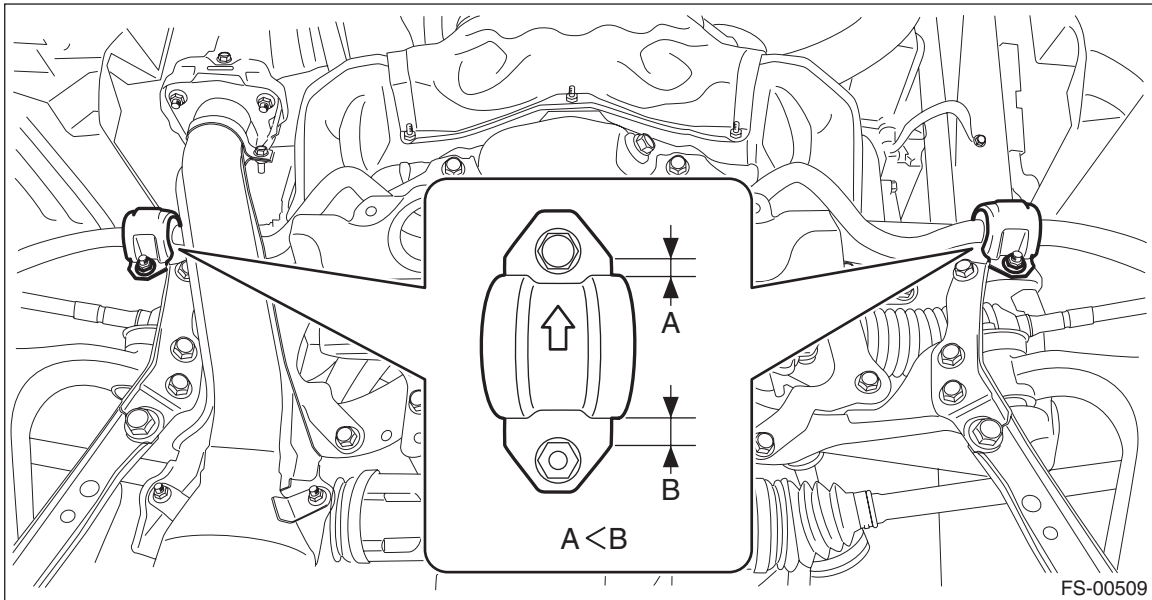

Tightening torque:

25 N·m (2.55 kgf-m, 18.4 ft-lb)

4) Install the front wheels.

Tightening torque:

120 N·m (12.24 kgf-m, 88.5 ft-lb)

C: INSPECTION

1) Check that there is no play by moving the upper and lower portions of front tire in an axial direction with the brake pedal depressed.

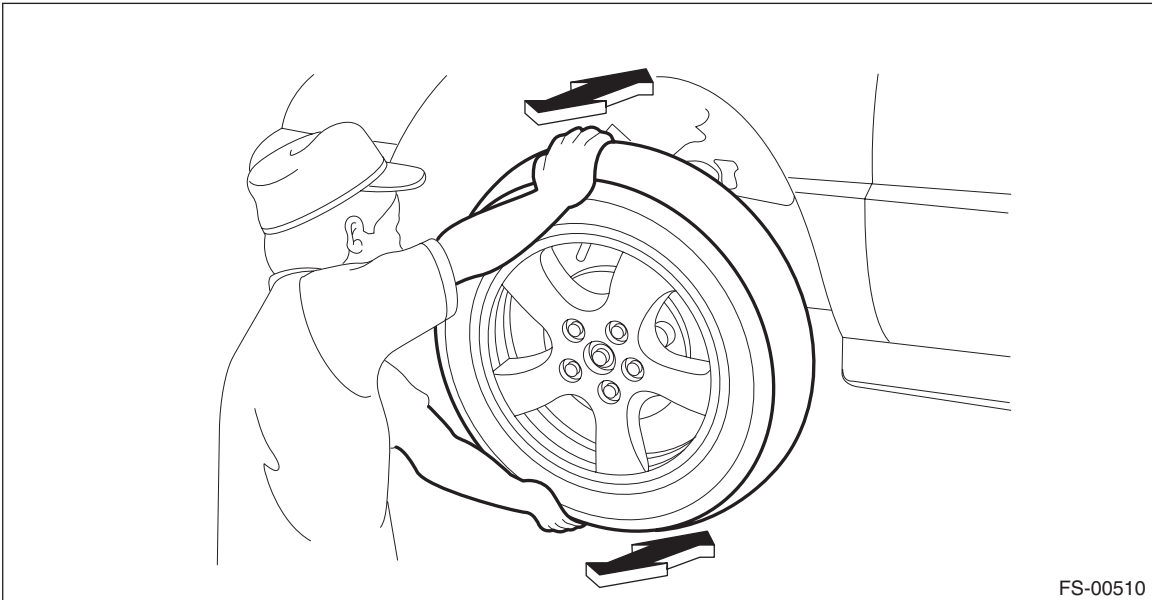

- **Play exists.** → Replace the ball joint assembly. <Ref. to FS-32, REMOVAL, Front Ball Joint.>
- 2) Check that there is no play by moving the upper and lower portions of front tire in an axial direction with the brake pedal released.
- **Play exists.** → Check the hub unit COMPL - front axle. <Ref. to DS-34, INSPECTION, Front Hub Unit Bearing.>
- 3) Replace the ball joint assembly if the dust cover is damaged when visually inspecting the dust cover.