

### 3. Rear Sub Frame

#### A: REMOVAL

- 1) Disconnect the ground cable from battery.
- 2) Lift up the vehicle, and then remove the rear wheels.
- 3) Remove the propeller shaft assembly. <Ref. to DS-12, REMOVAL, Propeller Shaft.>
- 4) Remove the clip and bolt on the harness clamp, and remove the rear ABS wheel speed sensor.

#### CAUTION:

- Be careful not to damage the sensor.
- Do not apply excessive force to the sensor harness.
- Except for XV model

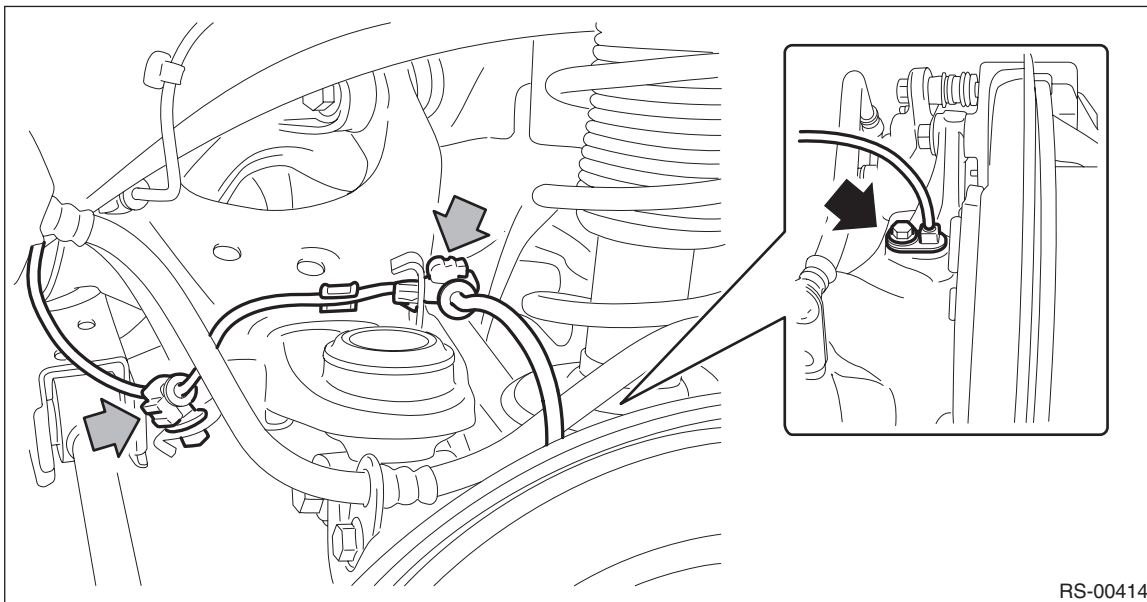

- XV model

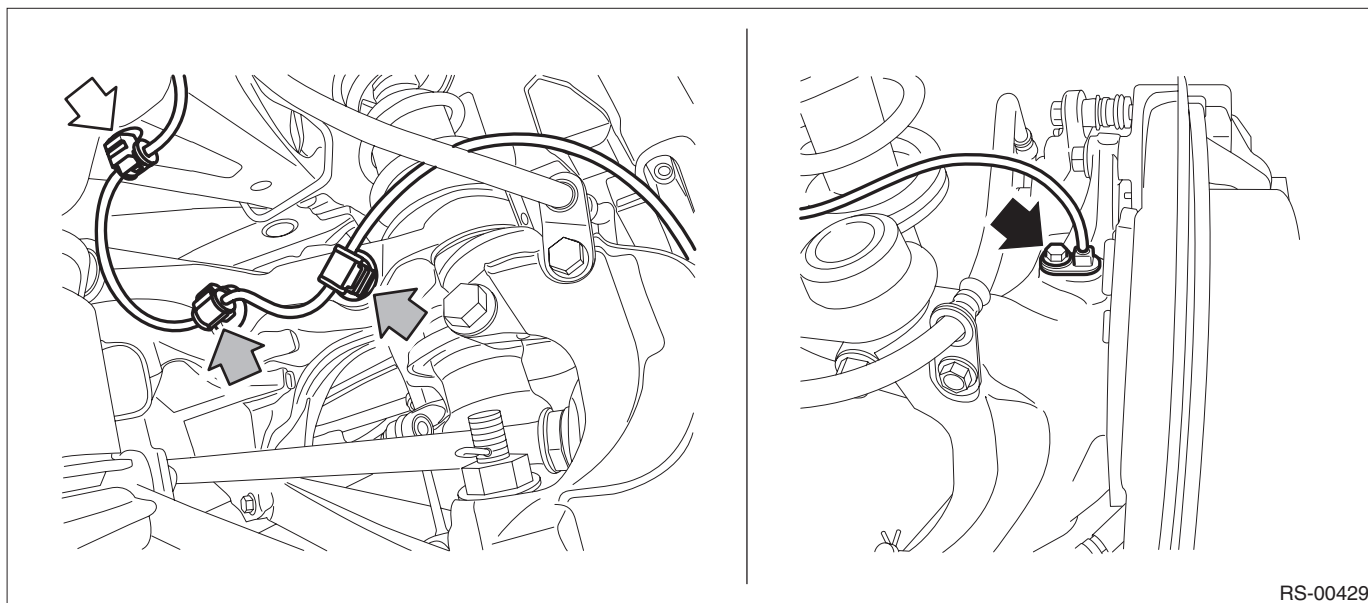

## Rear Sub Frame

### REAR SUSPENSION

5) Remove the caliper body assembly from the housing assembly - rear axle.

(1) Remove the bolts and then remove the brake hose bracket and caliper body assembly.

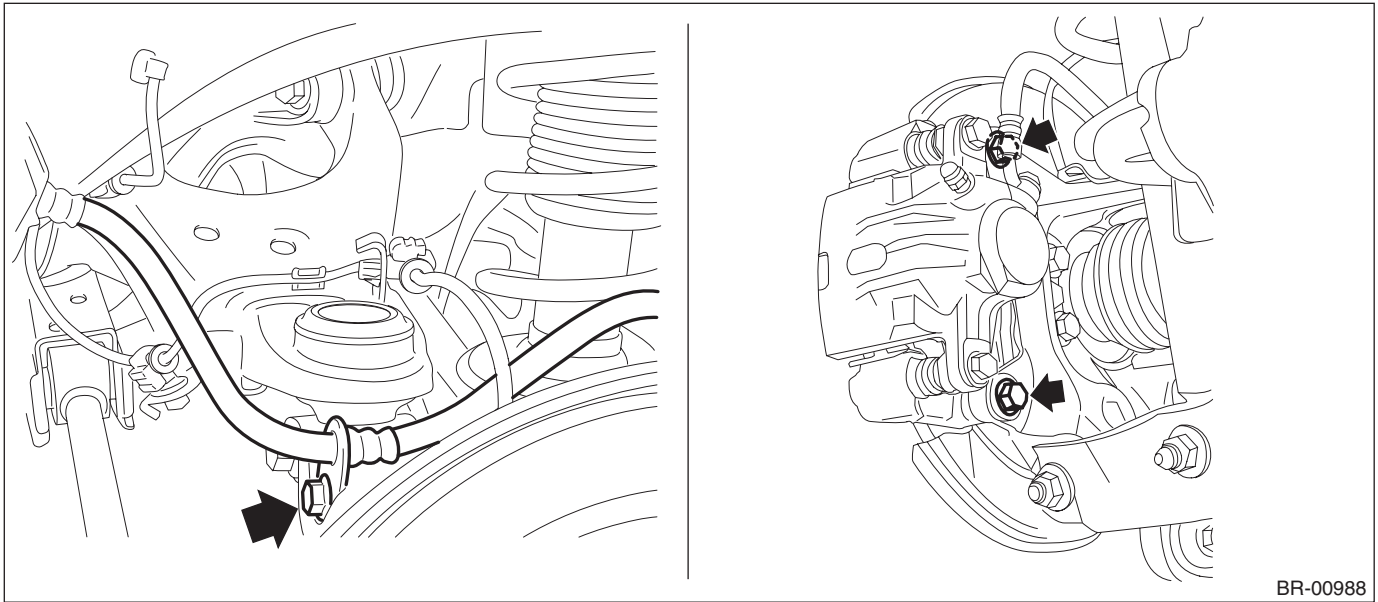

(2) Prepare wiring harnesses etc. to be discarded, and suspend the caliper body assembly from the strut assembly.

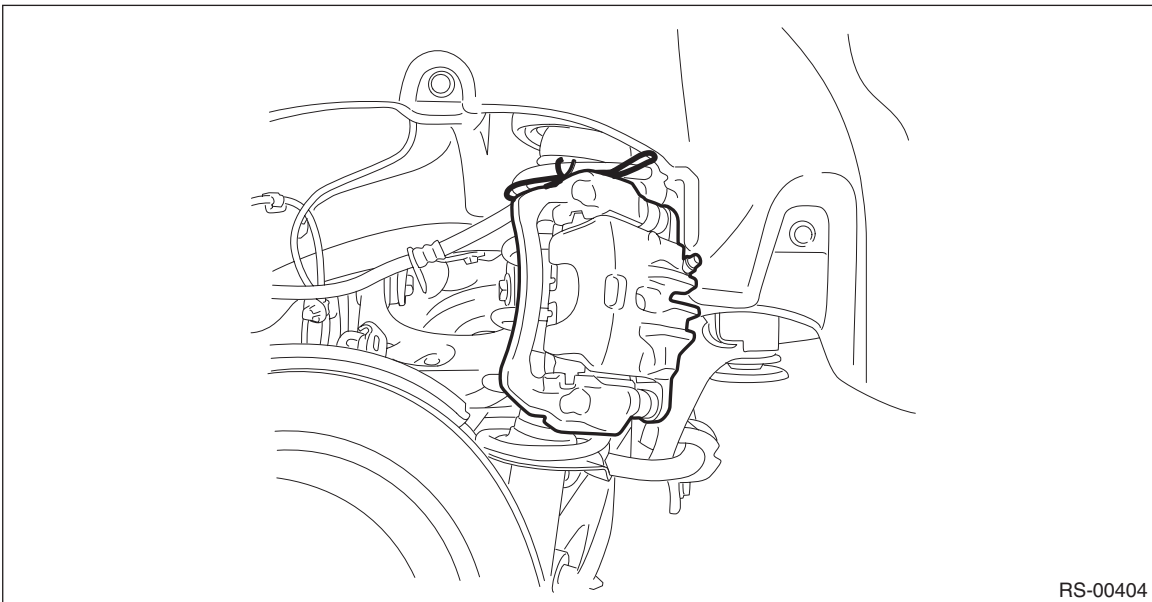

6) Remove the rear parking brake cable from the parking brake assembly. <Ref. to PB-15, REMOVAL, Parking Brake Assembly (Rear Disc Brake).>

7) Remove the sensor assembly - headlight beam leveler. (Model with auto headlight beam leveler, left side only)

- (1) Disconnect the connector of the sensor assembly - headlight beam leveler.
- (2) Remove the nuts, and remove the sensor assembly - headlight beam leveler.

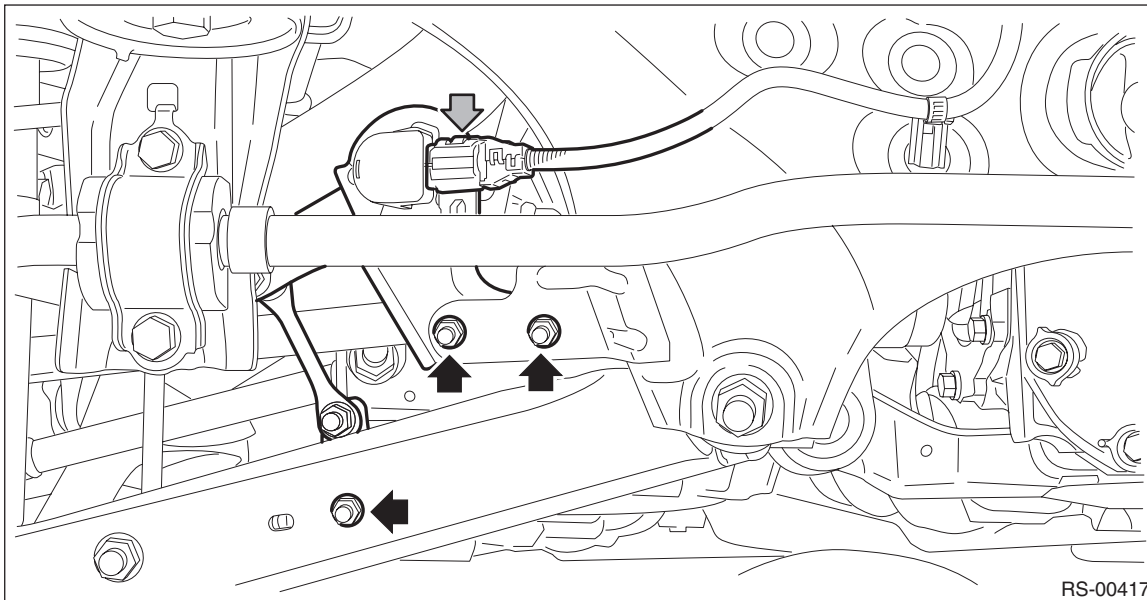

8) Remove the bolt and nuts and remove the fuel tank protector.

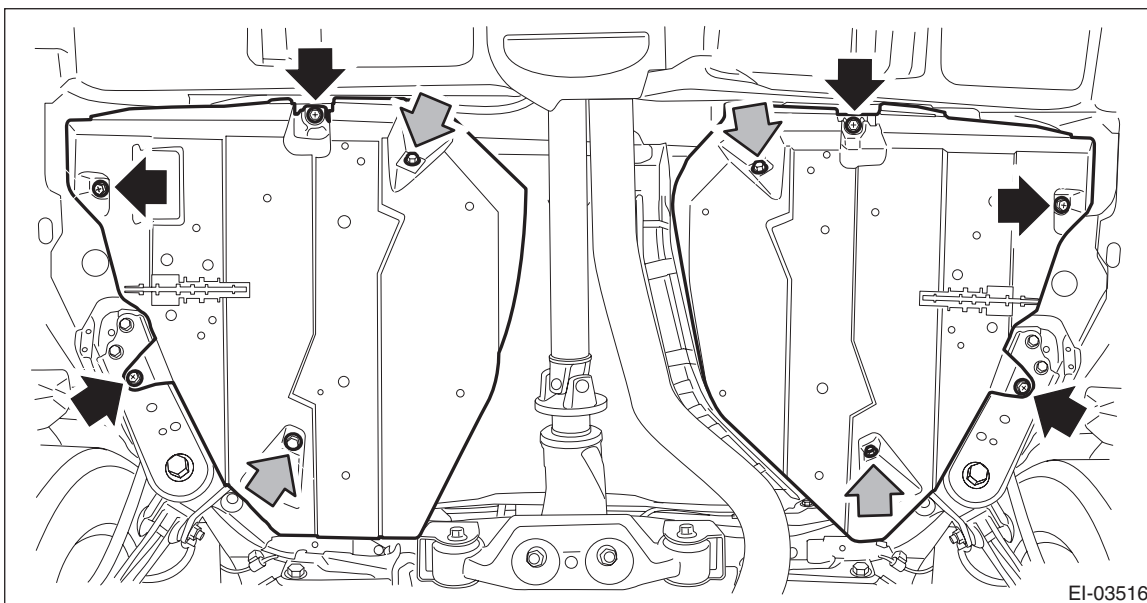

## Rear Sub Frame

### REAR SUSPENSION

9) Remove the rear sub frame assembly.

(1) Remove the bolts at the bottom of rear strut assembly.

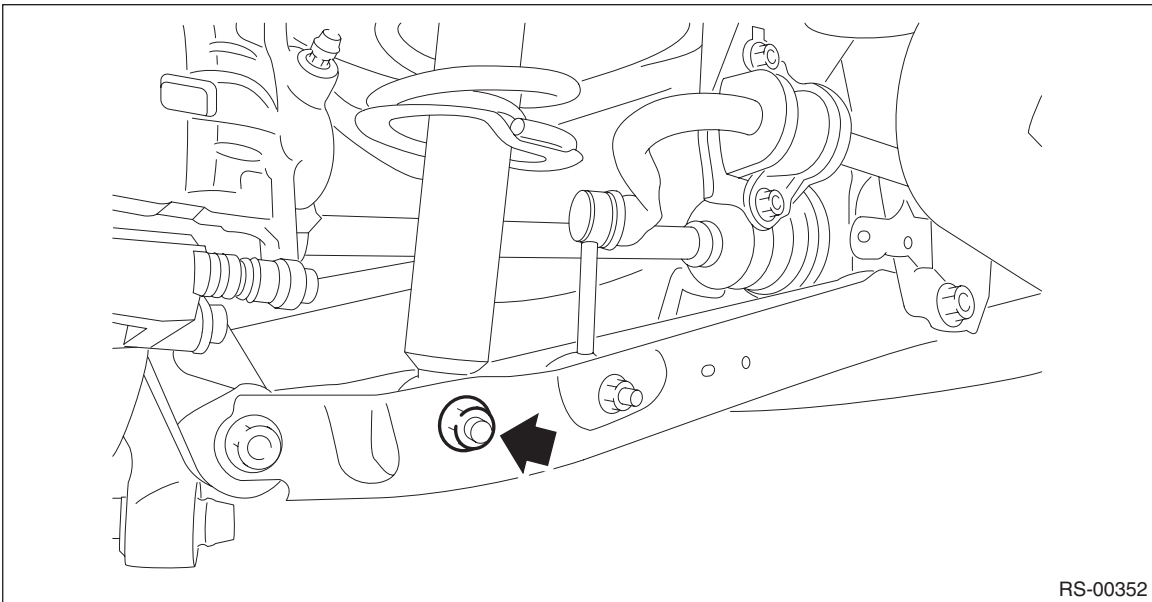

RS-00352

(2) Support the rear sub frame assembly using a transmission jack.

(3) Remove the bolt, and remove the left and right sub frame supports.

(4) Remove the bolts, then remove the rear sub frame assembly.

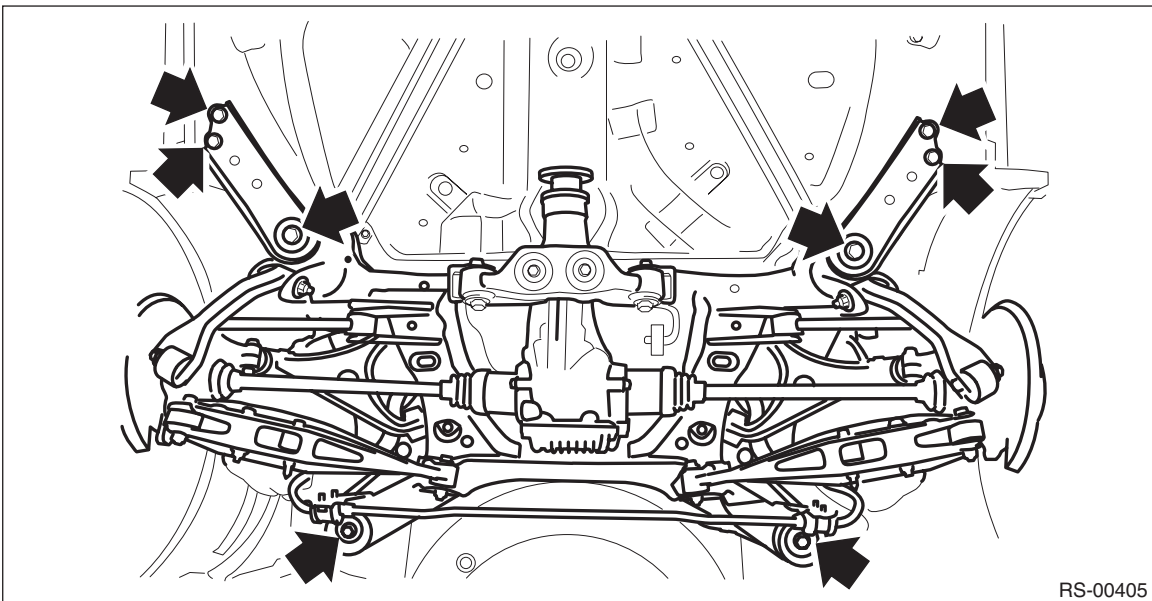

RS-00405

10) As necessary, remove each part from the rear sub frame assembly.

## B: INSTALLATION

### CAUTION:

- Be sure to use a new self-locking nut.
- Always tighten the bushing in the state where the vehicle is at curb weight and the wheels are in full contact with the ground.

- 1) Check the removed parts for wear, damage and crack, and repair or replace them if faulty.
- 2) Install each part in the reverse order of removal.

### Tightening torque:

Refer to “COMPONENT” of “General Description” for the tightening torque.

- Rear suspension parts: <Ref. to RS-3, COMPONENT, General Description.>
- Fuel tank protector: <Ref. to FU(H4DO)-7, FUEL TANK, COMPONENT, General Description.>
- Rear disc brake parts: <Ref. to BR-6, REAR DISC BRAKE, COMPONENT, General Description.>

- 3) Bleed air from brake system.
- 4) Install the rear wheels.

### Tightening torque:

**120 N·m (12.24 kgf-m, 88.5 ft-lb)**

- 5) Inspect the wheel alignment and adjust if necessary.
- Inspection: <Ref. to FS-7, INSPECTION, Wheel Alignment.>
  - Adjustment: <Ref. to FS-12, ADJUSTMENT, Wheel Alignment.>

### CAUTION:

**When the wheel alignment has been adjusted, perform “VDC sensor midpoint setting mode” of the VDC.**

- 6) Connect the battery ground terminal.
- 7) Perform reinitialization of the auto headlight beam leveler system. (model with auto headlight beam leveler) <Ref. to LI-17, PROCEDURE, Auto Headlight Beam Leveler System.>

## C: INSPECTION

Check the removed parts for wear, damage and crack, and repair or replace them if faulty.