

Rear Trailing Link

REAR SUSPENSION

5. Rear Trailing Link

A: REMOVAL

- 1) Lift up the vehicle, and then remove the rear wheels.
- 2) Remove the bolts and nuts, and then remove the trailing link.

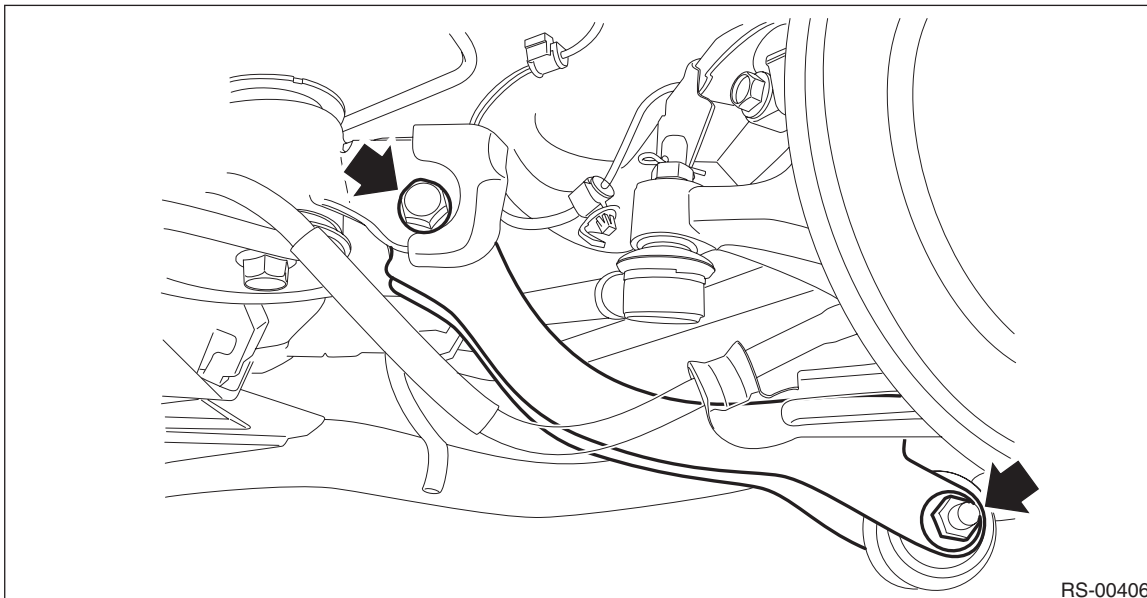

RS-00406

B: INSTALLATION

CAUTION:

- Be sure to use a new self-locking nut.
- Always tighten the bushing in the state where the vehicle is at curb weight and the wheels are in full contact with the ground.

- 1) Install each part in the reverse order of removal.

Tightening torque:

Trailing link — rear sub frame assembly: 90 N·m (9.18 kgf-m, 66.4 ft-lb)

Trailing link — housing assembly - rear axle: 90 N·m (9.18 kgf-m, 66.4 ft-lb)

- 2) Install the rear wheels.

Tightening torque:

120 N·m (12.24 kgf-m, 88.5 ft-lb)

C: DISASSEMBLY

1. BUSHING A - TRAILING LINK

Using the ST, push out the bushing A - trailing link.

Preparation tool:

ST-A: INSTALLER (899874100)

ST-B: INSTALLER & REMOVER (BASE) (20099PA010)

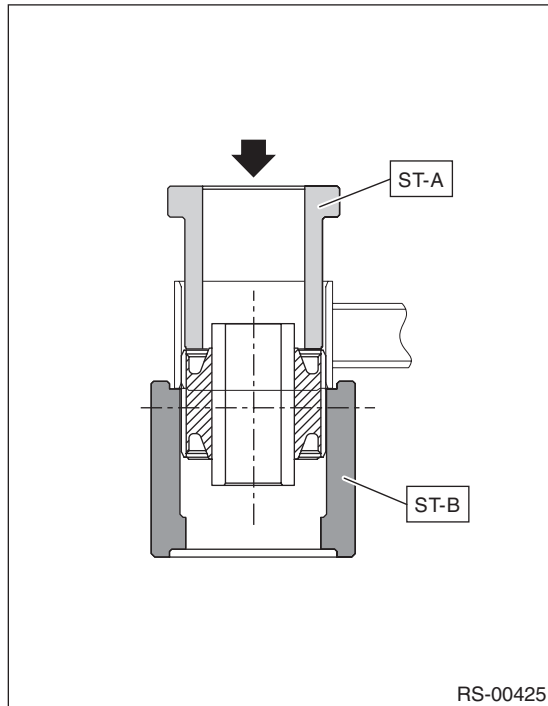

2. BUSHING - TRAILING LINK

For the removal procedure of bushing - trailing link, refer to "Rear Axle" in the "DRIVE SHAFT SYSTEM" section. <Ref. to DS-44, BUSHING - TRAILING LINK, DISASSEMBLY, Rear Axle.>

Rear Trailing Link

REAR SUSPENSION

D: ASSEMBLY

1. BUSHING A - TRAILING LINK

- 1) Before assembly, inspect the following items and replace any faulty part with a new one.
 - Perform visual check for damage or bend on the trailing link.
 - Visually check the bushing for abnormal cracks, fatigue or damage.
- 2) Using the ST-A and ST-B, press-fit the bushing.

CAUTION:

Make sure to press the bushing straight in.

Preparation tool:

ST-A: INSTALLER (899874100)

ST-B: INSTALLER & REMOVER (BASE) (20099PA010)

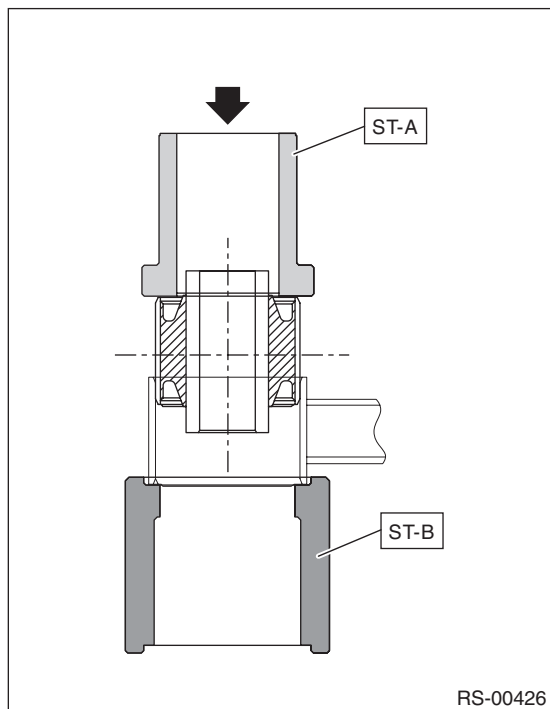

2. BUSHING - TRAILING LINK

For the installation procedure of bushing - trailing link, refer to "Rear Axle" in the "DRIVE SHAFT SYSTEM" section. <Ref. to DS-44, BUSHING - TRAILING LINK, DISASSEMBLY, Rear Axle.>