

Tire and Wheel

WHEEL AND TIRE SYSTEM

2. Tire and Wheel

A: REMOVAL

- 1) Remove the hubcap. (model with hubcap) <Ref. to WT-8, REMOVAL, Full Wheel Cap.>
- 2) Lift up the vehicle.
- 3) Remove the wheel nut.
- 4) Remove the wheels.

CAUTION:

When removing the wheels, be careful not to damage the bolt - hub.

B: INSTALLATION

- 1) Install the wheels to vehicle.
- 2) Tighten the wheel nuts to the specified torque.

Tightening torque:

120 N·m (12.24 kgf·m, 88.5 ft·lb)

C: INSPECTION

1. TIRE

CAUTION:

When replacing a tire, make sure to use tires of the same size, construction and load range as originally installed.

- 1) Tire size and tire inflation pressure check <Ref. to WT-2, SPECIFICATION, General Description.>
- 2) Cracks, damage and wear check
- 3) Tire runout check
 - (1) Lift up the vehicle.
 - (2) Slowly rotate the wheel to check rim "runout" using a dial gauge.

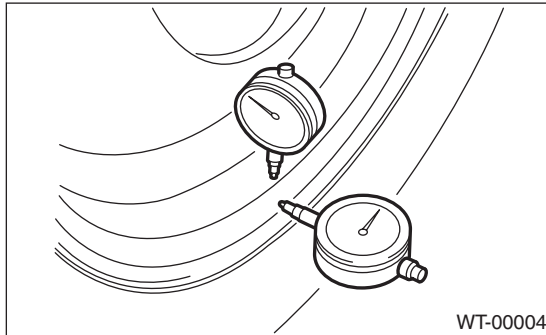

- Aluminum wheel

Axial runout limit	Radial runout limit
1.0 mm (0.039 in)	

- Steel wheel

Axial runout limit	Radial runout limit
1.5 mm (0.059 in)	

- (3) If the rim runout exceeds service limit, replace the wheel.

2. TIRE ROTATION

NOTE:

Rotate tires periodically (12,500 km/7,500 miles) in order to prolong life and to prevent uneven wear. Rotate tires as shown in the figure depending on whether or not the direction of the tire rotation is specified.

- When the direction of tire rotation is not specified

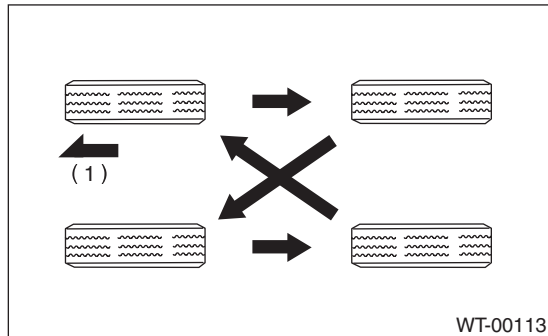

(1) Front side of vehicle

- When the direction of tire rotation is specified

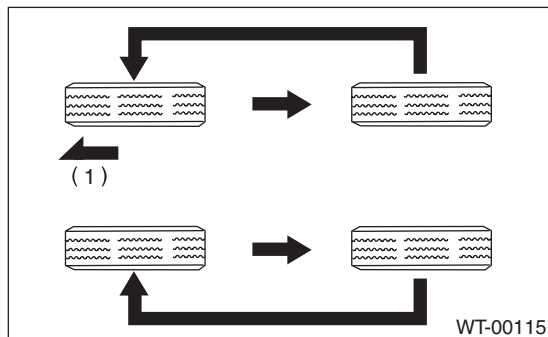

(1) Front side of vehicle

Tire and Wheel

WHEEL AND TIRE SYSTEM

3. WHEEL BALANCING

- 1) Using the wheel balancer, measure wheel balance.
- 2) Adjust the wheel balancing.

NOTE:

- Unbalance after adjusting the wheel balancing should be 5 g (0.18 oz) or less.
- When using the adhesive type weight, degrease the surface where the adhesive type weight will be applied securely.
- After applying the adhesive type weight, apply a force to the weight and attain full adhesion.
- Using the knock-on type weight, check the size of the knock-on part.

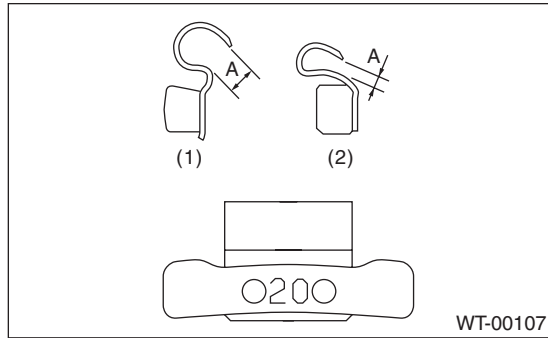

- (1) Knock-on type weight for aluminum wheel
- (2) Knock-on type weight for steel wheel

Service limit A:

Knock-on type weight for steel wheel: 2.0 mm (0.079 in)

Knock-on type weight for aluminum wheel: 5.0 mm (0.197 in)