

5. Tire Pressure Monitoring System

A: REMOVAL

1. TRANSMITTER (TIRE INFLATION PRESSURE SENSOR)

- 1) Remove the wheels from the vehicle. <Ref. to WT-4, REMOVAL, Tire and Wheel.>
- 2) Remove the tires from wheels.

CAUTION:

Use a tire changer when removing the tire from the wheel.

- 3) Loosen the screw to remove the transmitter from the valve stem.

CAUTION:

Do not reuse the valve and screw.

Replace the valve and screw with a new part even when reusing transmitter.

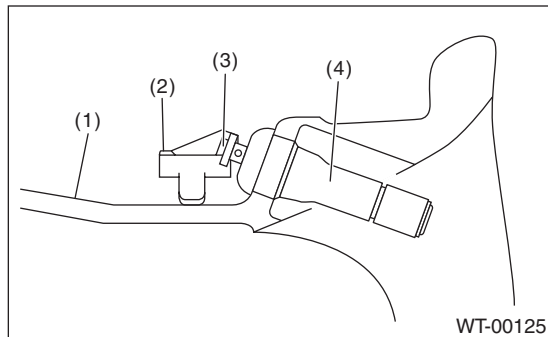

- (1) Wheel
- (2) Transmitter
- (3) Screw
- (4) Valve

- 4) Remove the valve from the wheel.

Tire Pressure Monitoring System

WHEEL AND TIRE SYSTEM

2. TPMS & KEYLESS CONTROL MODULE

NOTE:

TPMS control module is integrated with the keyless entry control module.

4 door model

- 1) Disconnect the ground cable from battery.
- 2) Remove the trim panel assembly - rear shelf. <Ref. to EI-112, REMOVAL, Rear Shelf Trim.>
- 3) Remove the TPMS & keyless control module.
 - (1) Disconnect the connector.
 - (2) Remove the bolt and then remove the TPMS & keyless control module.

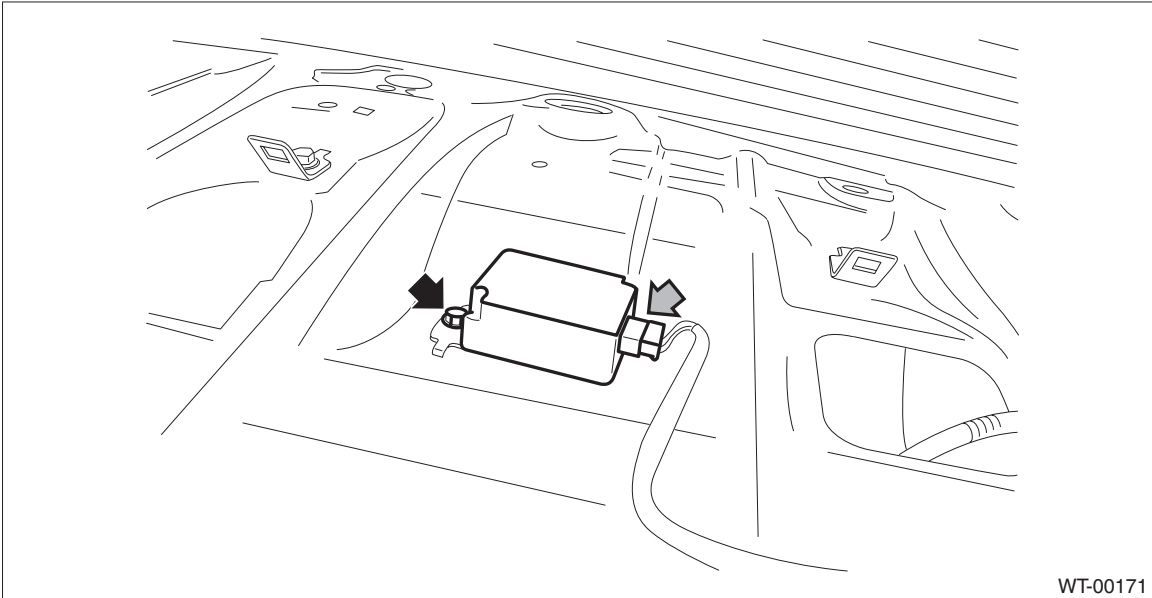

WT-00171

5 door model/XV model

- 1) Disconnect the ground cable from battery.
- 2) Remove the trim panel - rear apron LH. <Ref. to EI-108, 5 DOOR MODEL/XV MODEL, REMOVAL, Rear Quarter Trim.>
- 3) Remove the TPMS & keyless control module.
 - (1) Disconnect the connector.
 - (2) Remove the bolt and then remove the TPMS & keyless control module.

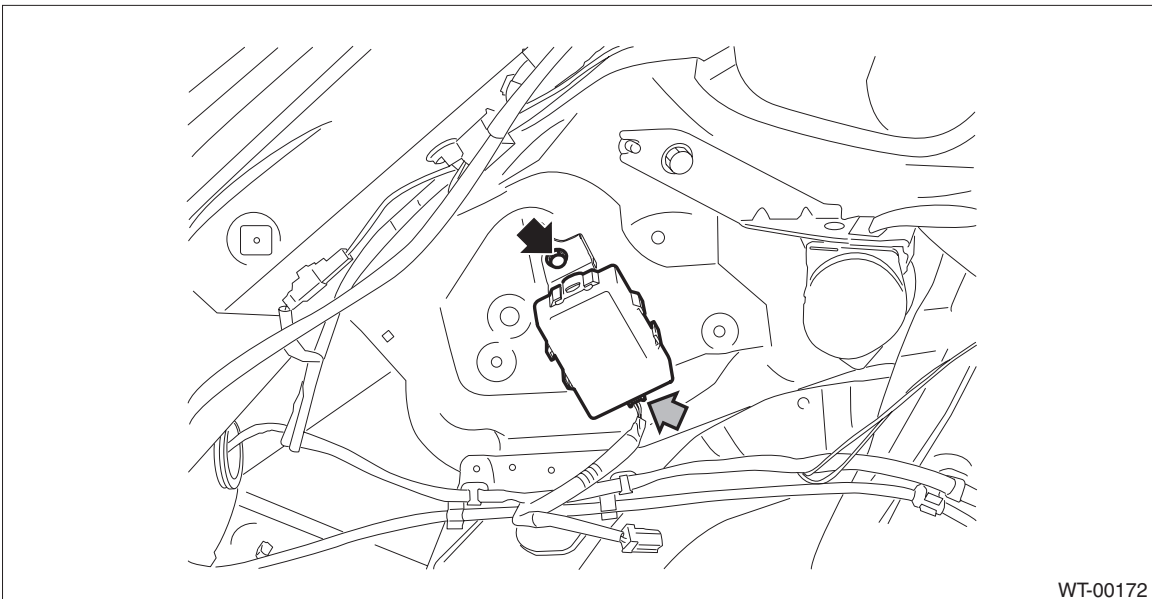

WT-00172

B: INSTALLATION

1. TRANSMITTER (TIRE INFLATION PRESSURE SENSOR)

CAUTION:

Use the new transmitter assembly or replace the new valve and screw, when installing.

1) Replace the valve and screw with a new part when reusing transmitter.

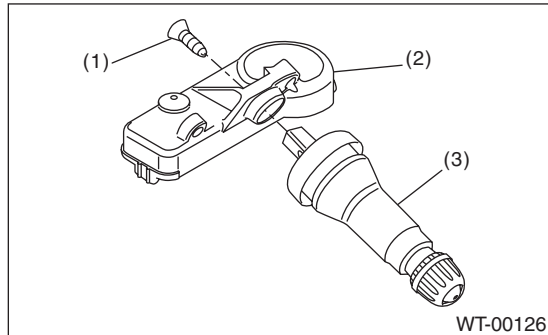

- (1) Screw
- (2) Transmitter
- (3) Valve

Tightening torque:

1.4 N·m (0.14 kgf·m, 1.0 ft·lb)

2) Install the transmitter to the wheel by aligning it with valve hole.

NOTE:

When using the jig that pulls the valve cap by hooking its neck part, use another short-type cap.

3) Install the tires to wheels.

CAUTION:

- Use a tire changer when installing tire to wheel.
- To prevent damaging the transmitter, set the tire changer boom in the position as shown in the figure.

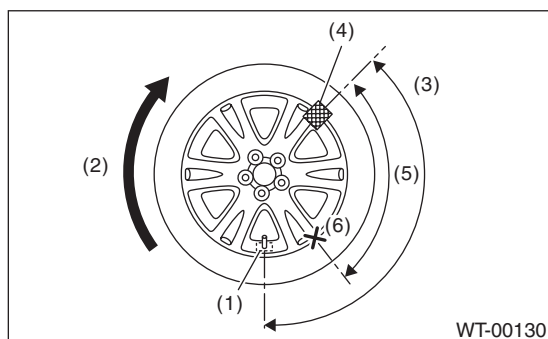

- (1) Transmitter
- (2) Direction of turn table rotation
- (3) 135°
- (4) Tire changer boom
- (5) 90°
- (6) Starting point for fitting the bead to the rim

4) Install the wheels to vehicle. <Ref. to WT-4, INSTALLATION, Tire and Wheel.>

5) Register the transmitter ID to the TPMS & keyless control module. <Ref. to TPM(diag)-13, Register Transmitter (ID).>

Tire Pressure Monitoring System

WHEEL AND TIRE SYSTEM

2. TPMS & KEYLESS CONTROL MODULE

Install each part in the reverse order of removal.

Tightening torque:

13 N·m (1.33 kgf-m, 9.6 ft-lb)

C: ADJUSTMENT

Re-register the transmitter ID when transmitter has been replaced. <Ref. to TPM(diag)-13, Register Transmitter (ID).>