

# Rear Differential (T-type)

## DIFFERENTIALS

### 4. Rear Differential (T-type)

#### A: REMOVAL

- 1) Shift the select lever or gear shift lever to neutral.
- 2) Disconnect the ground cable from battery.
- 3) Release the parking brake.
- 4) Loosen the wheel nuts.
- 5) Lift up the vehicle.
- 6) Remove the rear wheels.
- 7) Drain differential gear oil. <Ref. to DI-19, REPLACEMENT, Differential Gear Oil.>
- 8) Remove the rear exhaust pipe. <Ref. to EX(H4DO)-15, REMOVAL, Rear Exhaust Pipe.>
- 9) Remove the center exhaust cover.

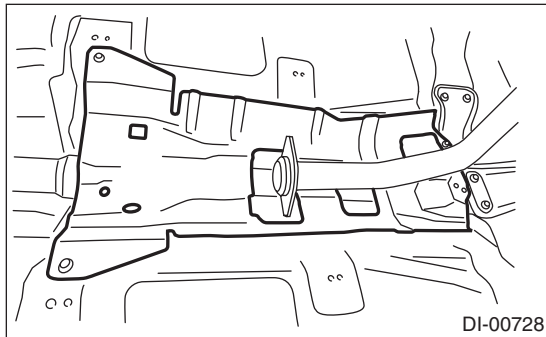

- 10) Remove the propeller shaft. <Ref. to DS-12, REMOVAL, Propeller Shaft.>
- 11) Loosen the self-lock nuts which hold the rear differential to the rear sub frame assembly.

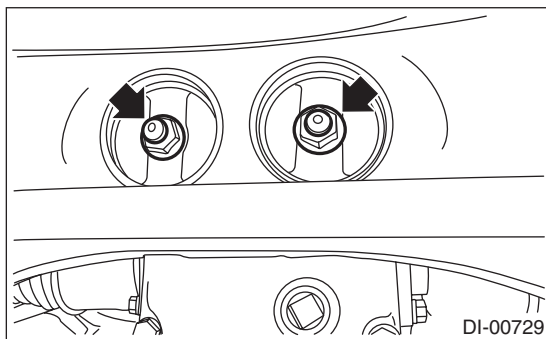

- 12) Remove the DOJ of rear drive shaft from rear differential using ST or tire lever.

#### NOTE:

- For the T-type, use the ST.
- For the VA-type, use the tire lever.
- When removing the DOJ from the rear differential, fit the tire lever or ST to the bolts as shown in the figure so as not to damage the side retainer.

#### T-type

ST 28099PA100 DRIVE SHAFT REMOVER

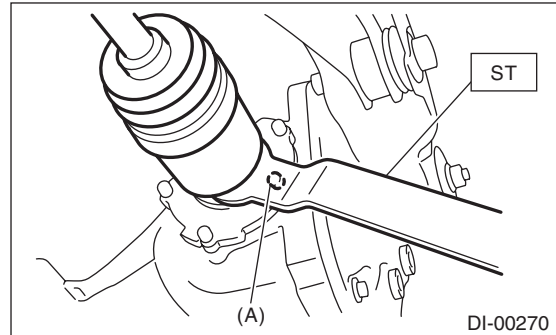

(A) Bolt

#### VA-type

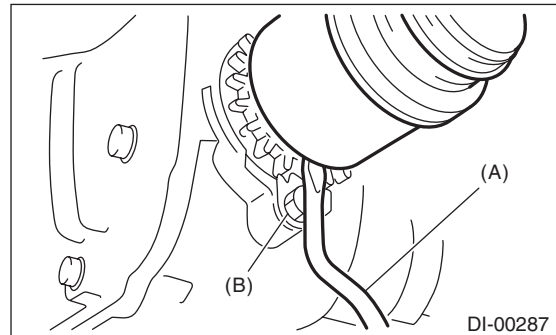

(A) Tire lever

(B) Bolt

- 13) Set the rear differential to transmission jack.

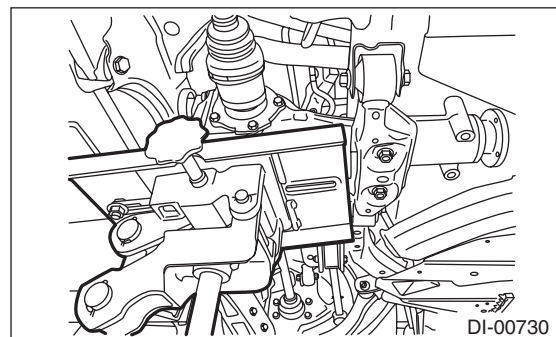

14) Remove the rear differential front member.

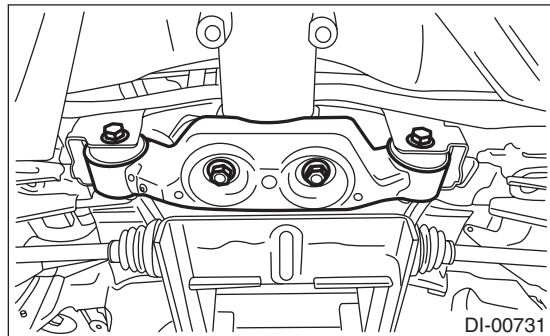

15) Remove the self-lock nuts which hold the rear differential to the rear sub frame assembly.

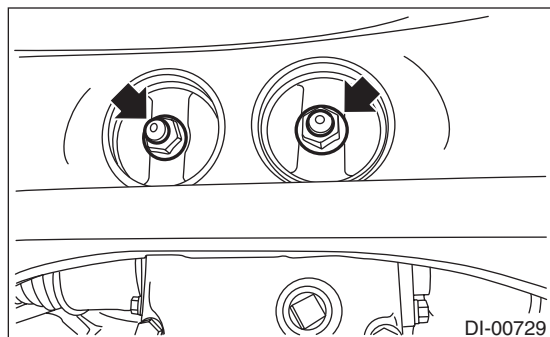

16) Pull out the rear differential stud bolt from rear differential mount bushing.

NOTE:

When removing the stud bolt from the rear differential mount bushing, carefully adjust the angle and location of transmission jack and jack stand, if necessary.

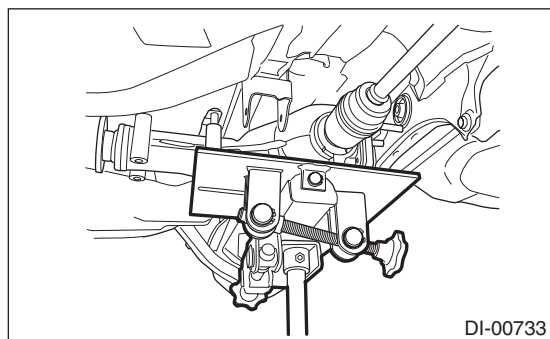

17) Lower the transmission jack.

18) Pull out the rear drive shaft from the rear differential.

NOTE:

If it is difficult to pull out the rear drive shaft from rear differential, use the ST for T-type and the tire lever for VA-type.

ST 28099PA100 DRIVE SHAFT REMOVER

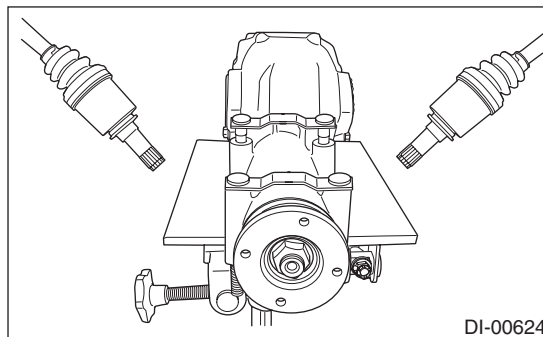

19) Lower the transmission jack.

20) Secure the rear drive shaft to rear lateral link using wire.

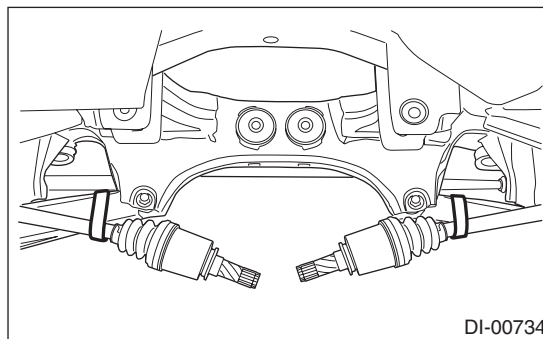

21) Remove the rear differential member plate from rear differential.

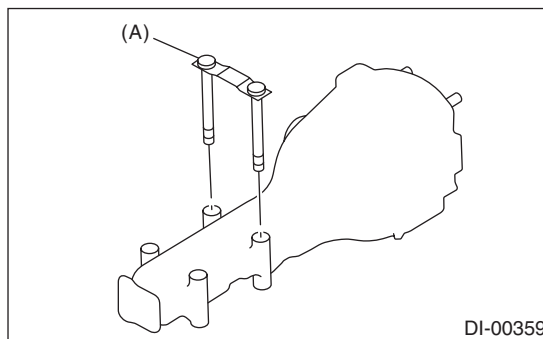

(A) Rear differential member plate

# Rear Differential (T-type)

## DIFFERENTIALS

### B: INSTALLATION

1) Attach the rear differential member plate to the rear differential.

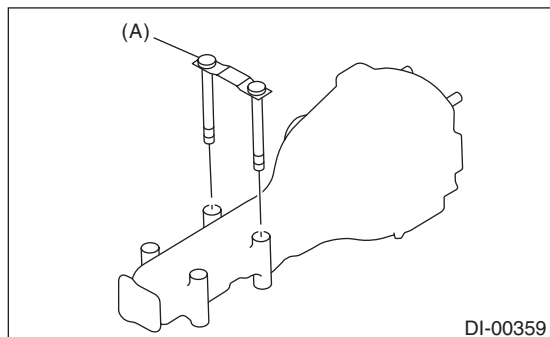

(A) Rear differential member plate

2) Set the rear differential to transmission jack.

3) Set the ST to the rear differential.

ST 28099PA090 OIL SEAL PROTECTOR

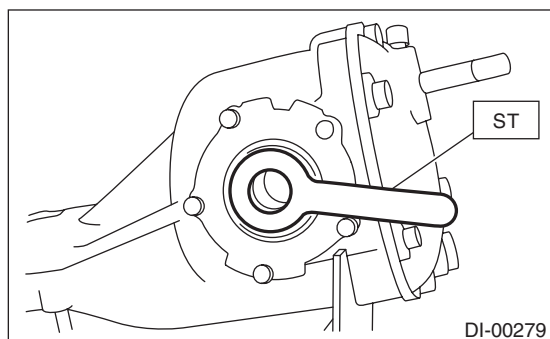

4) Insert the rear drive shaft until the spline portion of the rear drive shaft exceeds the side oil seal.

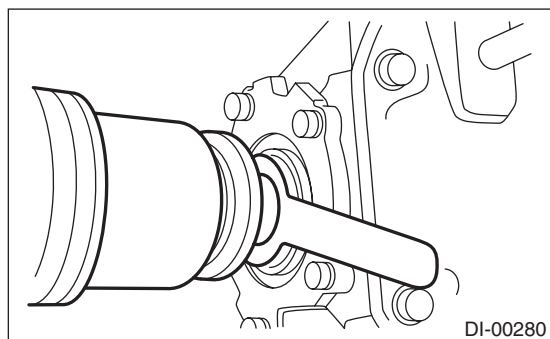

5) Remove ST from rear differential.

6) Push the rear differential from side to side to insert the DOJ into rear differential completely.

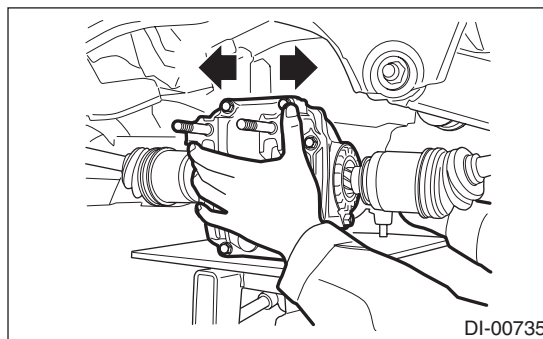

7) Adjust the transmission jack, if necessary, and insert the rear differential stud bolt into the rear differential mount bushing properly.

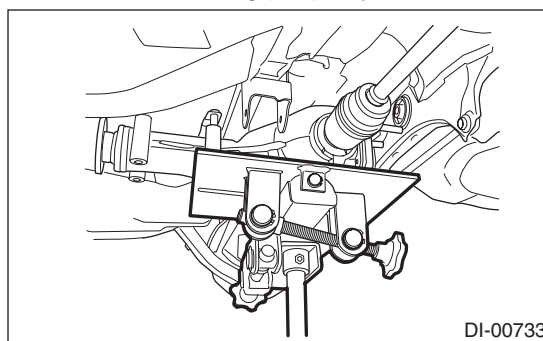

8) After inserting the rear differential stud bolt into the rear differential mount bushing, lift up the transmission jack and align the rear differential to its attachment position.

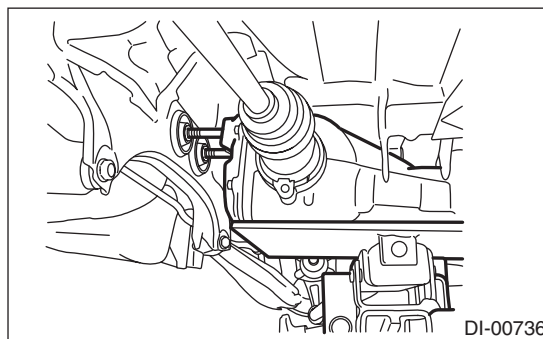

9) Tighten a new self-locking nut temporarily to the rear differential stud bolt.

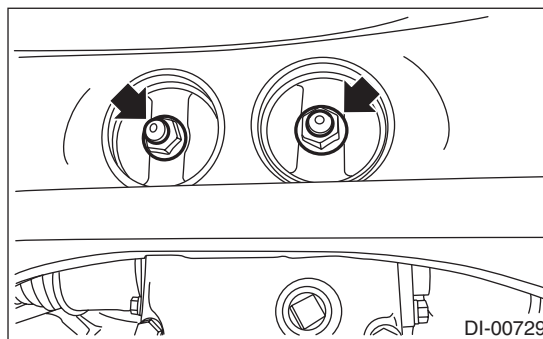

10) Install the rear differential front member with a new self-locking nut.

**Tightening torque:**

**T1: 50 N·m (5.1 kgf·m, 36.9 ft·lb)**

**T2: 110 N·m (11.2 kgf·m, 81.1 ft·lb)**

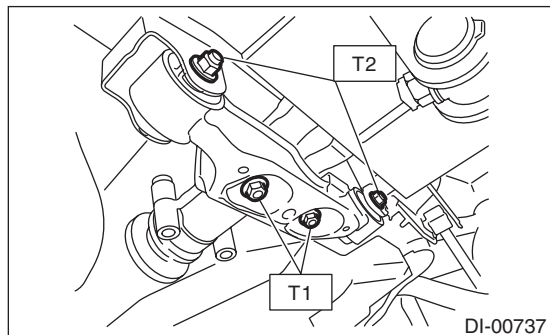

11) Remove the transmission jack.

12) Tighten the self-locking nut.

**Tightening torque:**

**70 N·m (7.1 kgf·m, 51.6 ft·lb)**

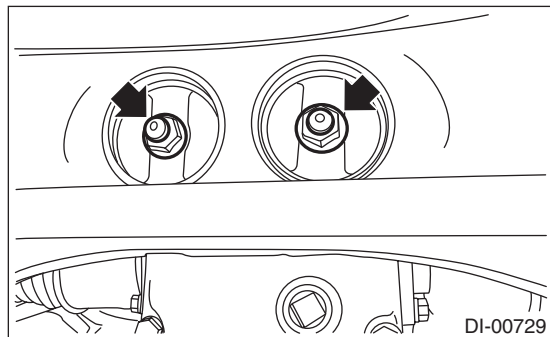

13) Install the propeller shaft. <Ref. to DS-13, INSTALLATION, Propeller Shaft.>

14) Install the center exhaust cover.

**Tightening torque:**

**18 N·m (1.8 kgf·m, 13.3 ft·lb)**

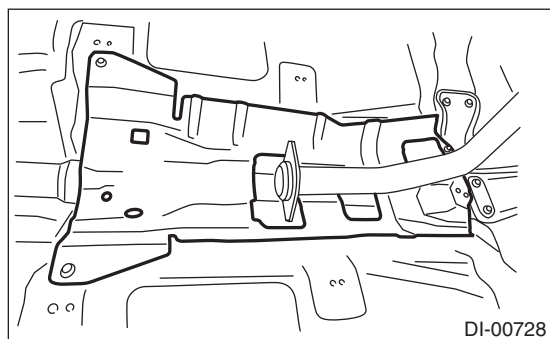

15) Install the rear exhaust pipe. <Ref. to EX(H4DO)-17, INSTALLATION, Rear Exhaust Pipe.>

16) Fill differential gear oil. <Ref. to DI-19, REPLACEMENT, Differential Gear Oil.>

17) Installing procedure hereafter is in the reverse order of removal.

18) Perform "Rear differential inspection mode" using the Subaru Select Monitor. (CVT model) <Ref. to DI-64, Rear Differential Inspection Mode.>

**CAUTION:**

Be sure to perform rear differential inspection mode when the following work has been performed.

- Replacement of rear differential
- Replacement of rear differential hypoid gear set
- Replacement of transmission assembly
- Replacement of front differential hypoid gear set

**C: DISASSEMBLY**

To detect the real cause of trouble, inspect the following items before disassembling.

- Tooth contact and backlash between hypoid driven gear and drive pinion
- Hypoid driven gear runout on its back surface
- Total preload of drive pinion

1) Set the ST on vise and install the differential assembly to ST.

ST 398217700 ATTACHMENT SET

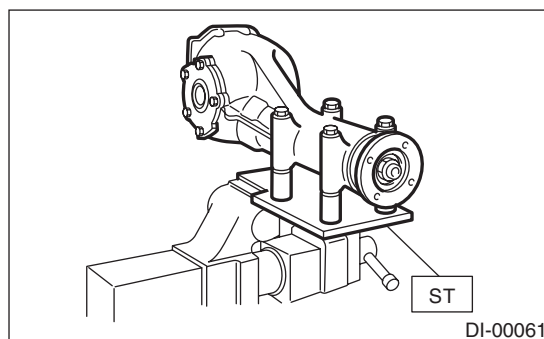

2) Remove the drain plug and filler plug.

3) Remove the air breather cap.

**NOTE:**

- Do not attempt to remove the air breather cap unless necessary.
- Whenever the air breather cap is removed, replace it with a new part.

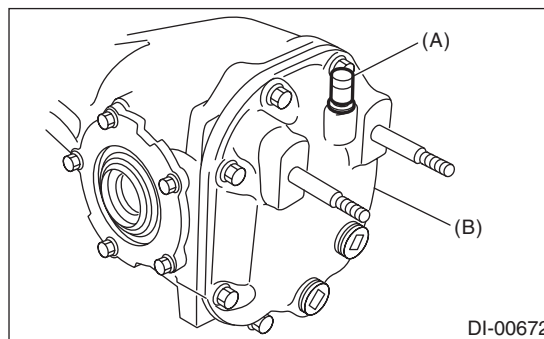

- (A) Air breather cap
- (B) Rear cover

## Rear Differential (T-type)

### DIFFERENTIALS

4) Remove the bolts, and then remove the rear cover.

5) Remove the side retainer attachment bolts, set the ST to differential case, and extract the side retainers RH and LH with a puller.

#### NOTE:

- Side retainer shim of each side should be kept together with its mating retainer.
- Keep the side retainers separate by attaching tags or in similar ways to make it possible to identify RH and LH sides during reassembly.

ST 398457700 ATTACHMENT

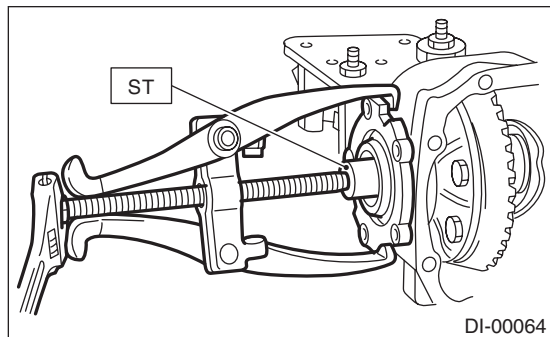

6) Pull out the differential case assembly from the differential carrier.

#### NOTE:

Be careful not to hit the teeth of hypoid driven gear against the differential carrier.

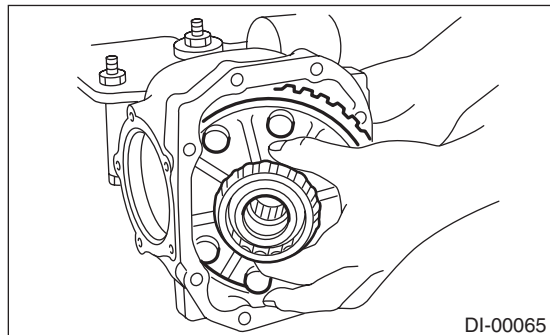

7) Remove the oil seal and O-ring from the side retainer.

8) When replacing the side bearing, remove the bearing race from the side retainer using ST.

ST 398527700 PULLER ASSY

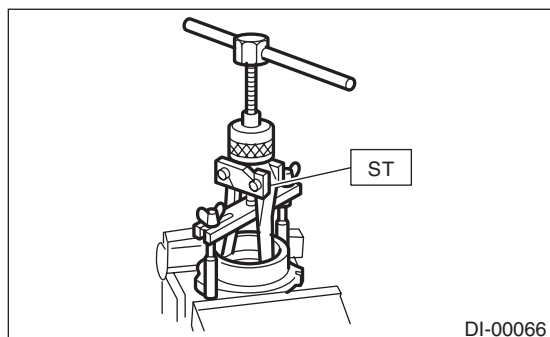

9) Using the ST, remove the bearing cone.

#### NOTE:

- Do not attempt to disassemble the parts unless necessary.
- Set the ST so that its claws catch the edge of the bearing cone.
- Never mix up the RH and LH bearing races and cones.

ST 18759AA000 PULLER ASSY

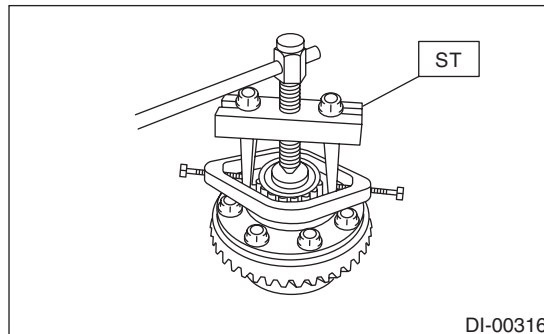

10) Remove the hypoid driven gear by loosening hypoid driven gear bolts.

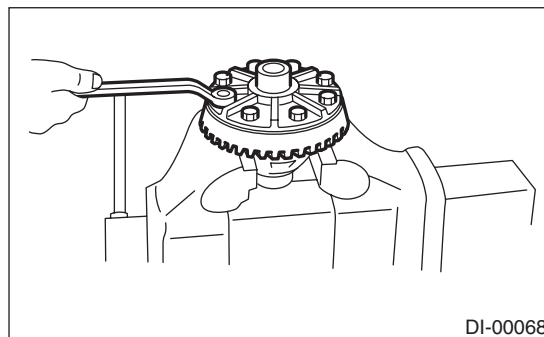

11) Remove the pinion shaft lock pin from hypoid driven gear side using ST.

ST 899904100 STRAIGHT PIN REMOVER

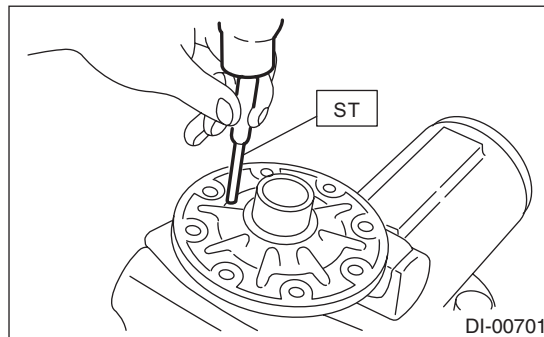

# Rear Differential (T-type)

12) Draw out the pinion mate shaft, and remove pinion mate gears, pinion mate gear washers, side gears, and side gear thrust washers.

**NOTE:**

The gears and washers should be marked with RH or LH, front or rear, or kept separately.

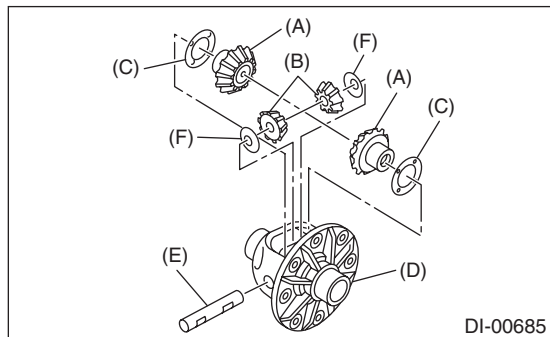

- (A) Side gear
- (B) Pinion mate gear
- (C) Side gear thrust washer
- (D) Differential case
- (E) Pinion mate shaft
- (F) Pinion mate gear washer

13) Remove the self-locking nut while securing the companion flange with ST.

ST 498427200 FLANGE WRENCH

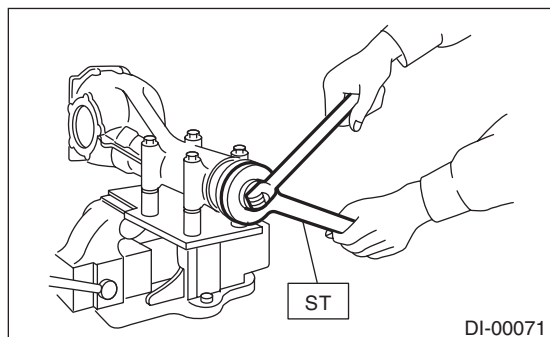

14) Extract the companion flange with a puller.

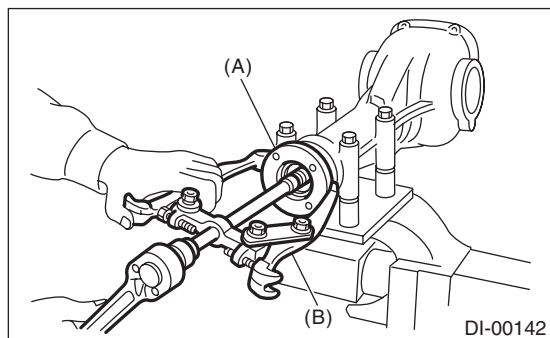

- (A) Companion flange
- (B) Puller

15) Press the end of drive pinion shaft using ST and remove the rear bearing cone, preload adjusting spacer and washer.

**NOTE:**

Hold the drive pinion so as not to drop it.

ST 398467700 DRIFT

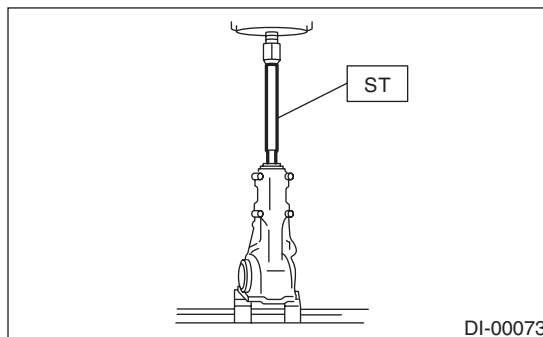

16) Remove the rear bearing cone from drive pinion by supporting the cone with ST.

**NOTE:**

Place the replacer so that its center-recessed side faces the bearing cone.

ST 398517700 REPLACER

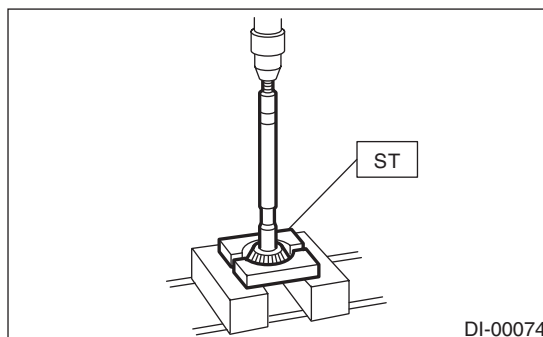

17) Remove the front oil seal from differential carrier using ST.

ST 398527700 PULLER ASSY

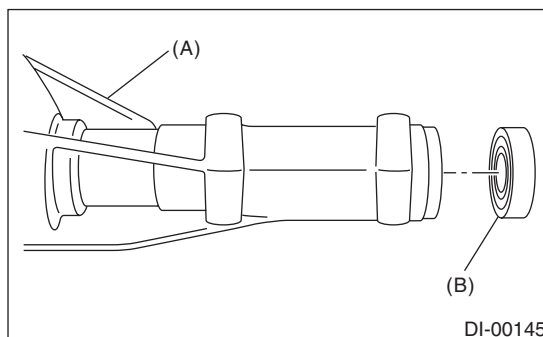

- (A) Differential carrier
- (B) Front oil seal

# Rear Differential (T-type)

## DIFFERENTIALS

18) Remove the pilot bearing together with the front bearing cone and spacer using the ST.  
ST 398467700 DRIFT

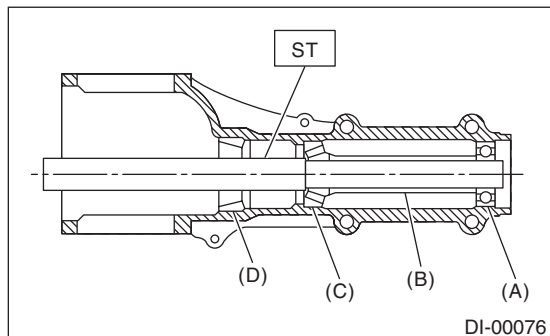

- (A) Pilot bearing
- (B) Spacer
- (C) Front bearing
- (D) Rear bearing race

19) When replacing the bearings, use a brass bar to tap out the front bearing race and rear bearing race in this order to remove them.

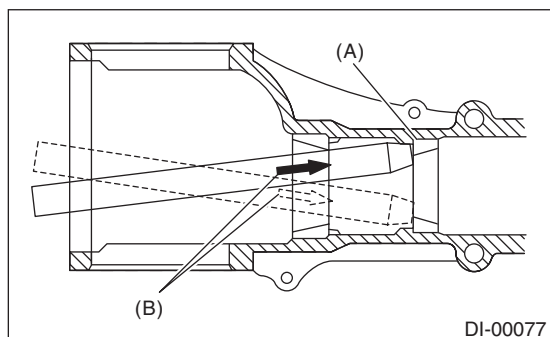

- (A) 2 cutout portions along diagonal lines
- (B) Tap alternately with brass bar.

## D: ASSEMBLY

### NOTE:

- Assemble in the reverse order of disassembly.
- Check and adjust each part during assembly.
- Keep the shims and washers in order, so that they are not improperly installed.
- Thoroughly clean the surfaces on which the shims, washers and bearings are to be installed.
- Apply gear oil when installing the bearings and thrust washers.
- Be careful not to mix up the RH and LH bearing races.
- Use a new O-ring and gasket.
- Replace the oil seal with a new part at every disassembly.
- Be careful not to mix up the oil seal RH and LH.
- Apply differential gear oil to the lips when installing the oil seal.

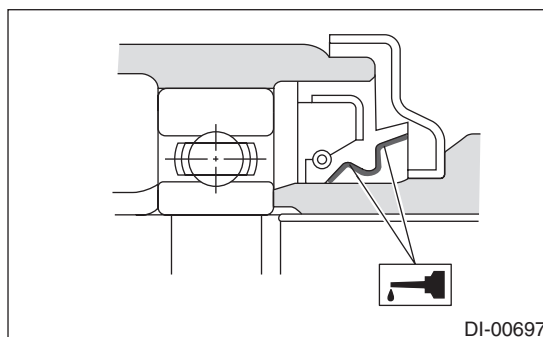

1) Adjusting preload for front and rear bearings

### NOTE:

Adjust the bearing preload between front and rear bearings with pre-load adjusting spacer and washer. Pinion height adjusting washer is not affected by this adjustment. The adjustment must not be carried out with oil seal inserted.

(1) Install the rear bearing race into the differential carrier using ST1 and ST2.

- ST1 398477701 HANDLE
- ST2 398477703 DRIFT 2

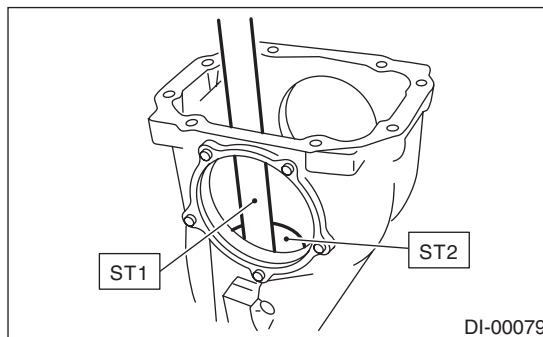

(2) Install the front bearing race to the differential carrier using ST1 and ST2.

**NOTE:**

Use a new front bearing race.

ST1 398477701 HANDLE

ST2 398477702 DRIFT

(3) Insert ST1 into the differential carrier with the pinion height adjusting washer and rear bearing cone fitted onto it.

**NOTE:**

If tooth contact (drive pinion, hypoid driven gear) is normal in the inspection before disassembling, verify that the washer is not deformed, and then re-use the used washer.

(4) Install the preload adjusting spacer and washer, front bearing cone, ST2, companion flange and self-locking nut.

ST1 398507702 DUMMY SHAFT

ST2 398507703 DUMMY COLLAR

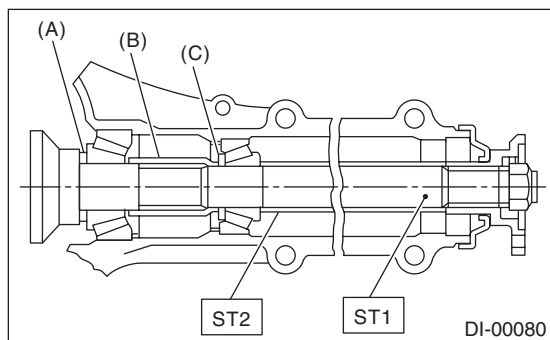

(A) Pinion height adjusting washer

(B) Preload adjusting spacer

(C) Preload adjusting washer

(5) Turn the ST1 by hand to smooth the bearing, and tighten the self-locking nut while measuring the initial load or initial torque with a spring scale or torque wrench. Select the preload adjusting washer and spacer so that the specified preload is obtained when nut is tightened to the specified torque.

**NOTE:**

- Use a new self-locking nut.
- Measure the preload in direction of tangent to the flange.
- Be careful not to give excessive preload.
- When tightening the self-locking nut, lock ST1 with ST2 as shown in the figure.

ST1 398507702 DUMMY SHAFT

ST2 398507704 BLOCK

**Tightening torque:**

**181.5 N·m (18.5 kgf·m, 133.9 ft·lb)**

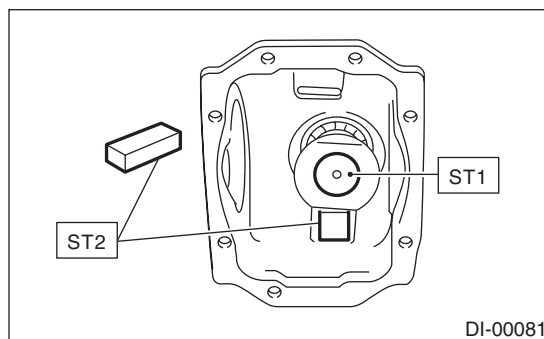

**Initial load:**

**18.1 — 38.8 N (1.8 — 4.0 kgf, 4.1 — 8.7 lbf)**

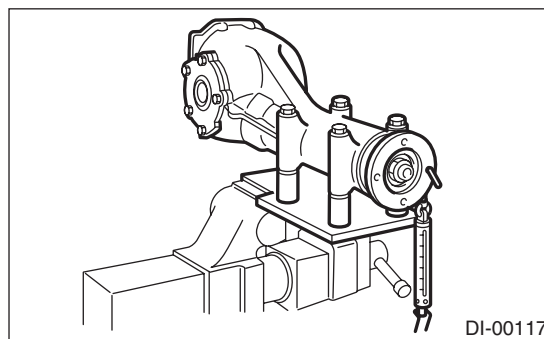

**Initial torque:**

**0.69 — 1.47 N·m (0.07 — 0.15 kgf·m, 0.51 — 1.08 ft·lb)**

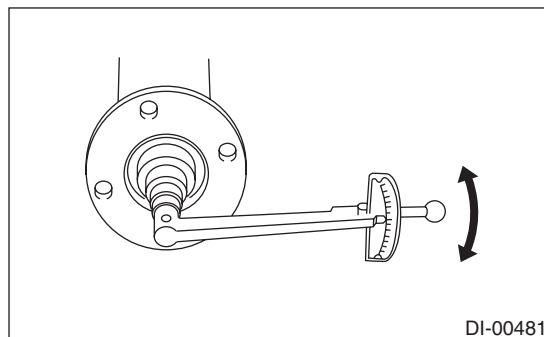



# Rear Differential (T-type)

## DIFFERENTIALS

Preload adjusting washer	
Part No.	Thickness mm (in)
383705200	2.59 (0.1020)
383715200	2.57 (0.1012)
383725200	2.55 (0.1004)
383735200	2.53 (0.0996)
383745200	2.51 (0.0988)
383755200	2.49 (0.0980)
383765200	2.47 (0.0972)
383775200	2.45 (0.0965)
383785200	2.43 (0.0957)
383795200	2.41 (0.0949)
383805200	2.39 (0.0941)
383815200	2.37 (0.0933)
383825200	2.35 (0.0925)
383835200	2.33 (0.0917)
383845200	2.31 (0.0909)

Preload adjusting spacer	
Part No.	Length mm (in)
383695201	56.2 (2.213)
383695202	56.4 (2.220)
383695203	56.6 (2.228)
383695204	56.8 (2.236)
383695205	57.0 (2.244)
383695206	57.2 (2.252)

### 2) Adjusting drive pinion height:

Adjust the drive pinion height with pinion height adjusting washer installed between the rear bearing cone and the back of pinion gear.

(1) Attach the ST2.

#### NOTE:

At this time, install a provisionally selected or previously used pinion height adjusting washer. Measure and record the thickness.

ST1 398507702 DUMMY SHAFT  
 ST2 398507701 DIFFERENTIAL CARRIER GAUGE  
 ST3 398507703 DUMMY COLLAR

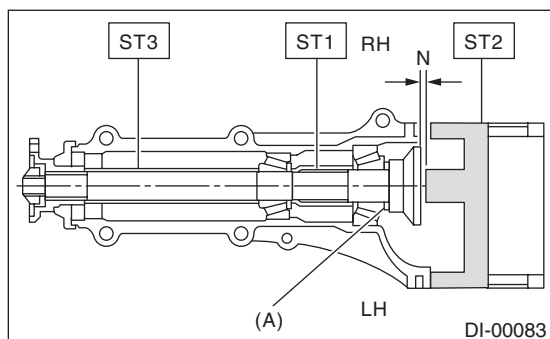

(A) Pinion height adjusting washer

(2) Measure the clearance "N" between the end of ST2 and the end surface of ST1 by using a thickness gauge.

#### NOTE:

Make sure there is no clearance between the differential carrier and ST2.

ST1 398507702 DUMMY SHAFT  
 ST2 398507701 DIFFERENTIAL CARRIER GAUGE

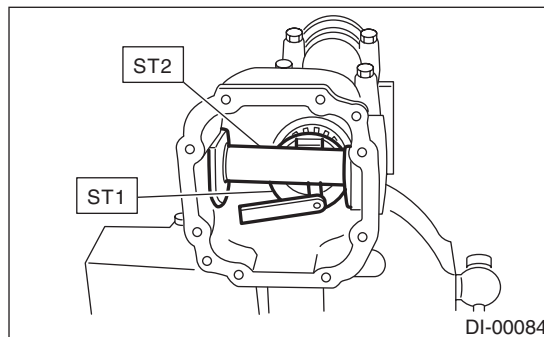

(3) Obtain the thickness of pinion height adjusting washer to be inserted from the following formula, and replace the temporarily installed washer with this one.

$$T = T_o + N - (H \times 0.01) - 0.20 \text{ mm (0.0079 in)}$$

T	Thickness of pinion height adjusting washer mm (in)	
T <sub>o</sub>	Thickness of washer temporarily inserted mm (in)	
N	Clearance of thickness gauge mm (in)	
H	Figure marked on drive pinion head	

Memo:

(Example of calculation)

$T_o = 3.39 \text{ mm (0.1335 in)}$

$N = 0.24 \text{ mm (0.0094 in)}$

$H = + 1$

$T = 3.39 \text{ mm (0.1335 in)} + 0.24 \text{ mm (0.0094 in)}$

$- 0.01 \text{ mm (0.0004 in)} - 0.20 \text{ mm (0.0079 in)} =$

$3.42 \text{ mm (0.1346 in)}$

Result: Thickness = 3.42 mm (0.1346 in)

Therefore use washer 383605200.

Pinion height adjusting washer	
Part No.	Thickness mm (in)
383495200	3.09 (0.1217)
383505200	3.12 (0.1228)
383515200	3.15 (0.1240)
383525200	3.18 (0.1252)
383535200	3.21 (0.1264)
383545200	3.24 (0.1276)
383555200	3.27 (0.1287)
383565200	3.30 (0.1299)
383575200	3.33 (0.1311)
383585200	3.36 (0.1323)
383595200	3.39 (0.1335)
383605200	3.42 (0.1346)
383615200	3.45 (0.1358)
383625200	3.48 (0.1370)
383635200	3.51 (0.1382)
383645200	3.54 (0.1394)
383655200	3.57 (0.1406)
383665200	3.60 (0.1417)
383675200	3.63 (0.1429)
383685200	3.66 (0.1441)

3) Install the selected pinion height adjusting washer on drive pinion, and press the rear bearing cone into position with ST.

ST 398177700 INSTALLER

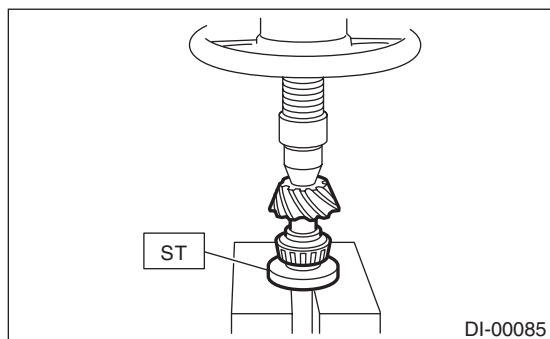

4) Insert the drive pinion into the differential carrier, and install the preselected preload adjusting spacer and washer.

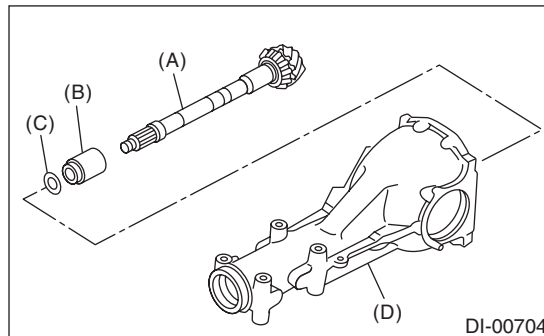

- (A) Drive pinion
- (B) Preload adjusting spacer
- (C) Preload adjusting washer
- (D) Differential carrier

5) Press-fit the front bearing cone with ST1, ST2 and ST3.

NOTE:

Use new front bearing cone.

ST1 398507703 DUMMY COLLAR

ST2 399780104 WEIGHT

ST3 899580100 INSTALLER

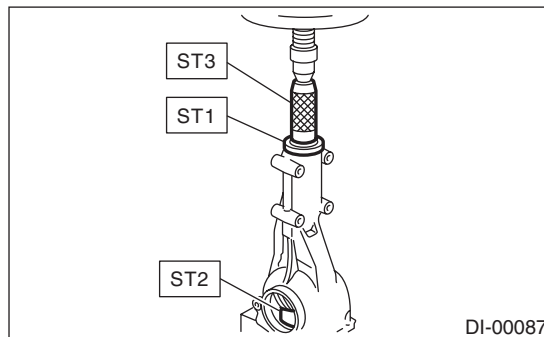

6) Insert the spacer, then press-fit the pilot bearing with ST1 and ST2.

NOTE:

Use a new pilot bearing.

ST1 399780104 WEIGHT

ST2 899580100 INSTALLER

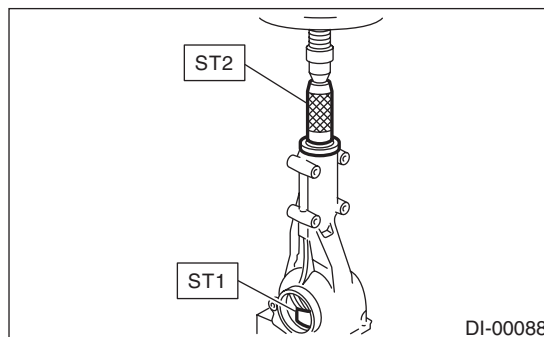

## Rear Differential (T-type)

### DIFFERENTIALS

7) Using the ST, install the oil seal.

**NOTE:**

- Use a new oil seal.
- Press-fit until the oil seal end comes 1 mm (0.04 in) inward from end of carrier.
- Apply differential gear oil to the oil seal lips.

ST 498447120 INSTALLER

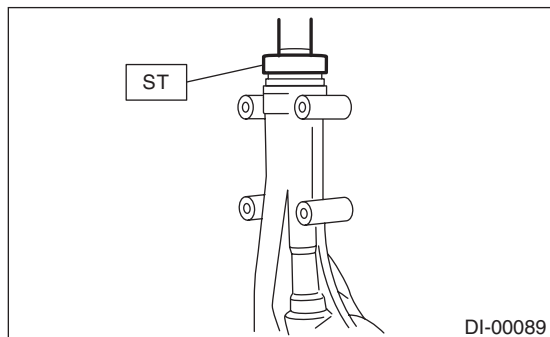

8) Press-fit the companion flange with ST1 and ST2.

**NOTE:**

Be careful not to damage the bearing.

ST1 899874100 INSTALLER

ST2 399780104 WEIGHT

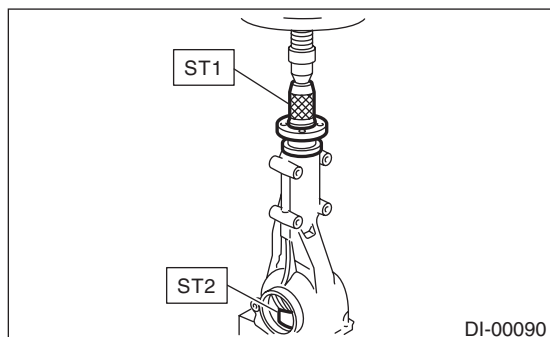

9) Apply seal material on the drive pinion shaft thread and new self-locking nut seat.

**Seal material:**

**THREE BOND 1324 (Part No. 004403042) or equivalent**

10) Attach the new self-locking nut and use the ST to fix the companion flange in place, then tighten the self-locking nut.

**Tightening torque:**

**181.5 N·m (18.5 kgf·m, 133.9 ft·lb)**

ST 498427200 FLANGE WRENCH

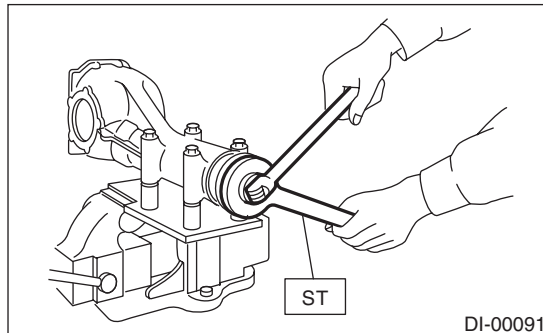

11) Check the initial torque or initial load.

**Initial load:**

**18.1 — 38.8 N (1.8 — 4.0 kgf, 4.1 — 8.7 lbf)**

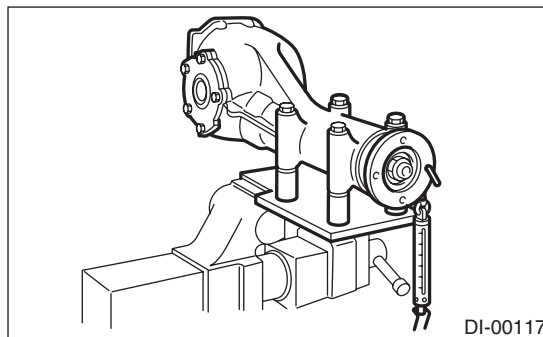

**Initial torque:**

**0.69 — 1.47 N·m (0.07 — 0.15 kgf·m, 0.51 — 1.08 ft·lb)**

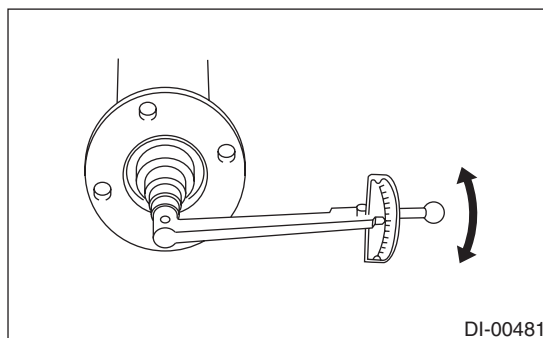

## 12) Assembling differential case

(1) Install the side gears and pinion mate gears, with their side gear thrust washers, pinion mate gear washer, and pinion mate shaft, into the differential case.

### NOTE:

- Apply gear oil on both sides of the washer and on the pinion mate shaft before installing.
- Insert the pinion mate shaft into the differential case by aligning the pin holes.

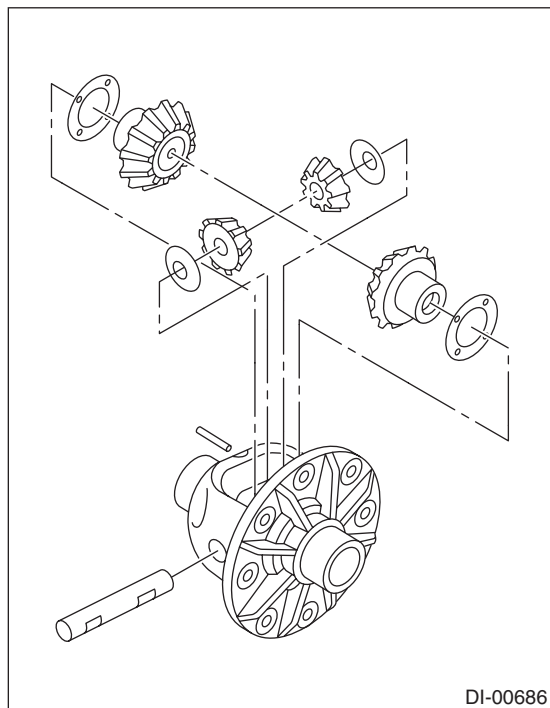

(2) Measure the side gear backlash.

### Side gear backlash:

**0.10 — 0.20 mm (0.004 — 0.008 in)**

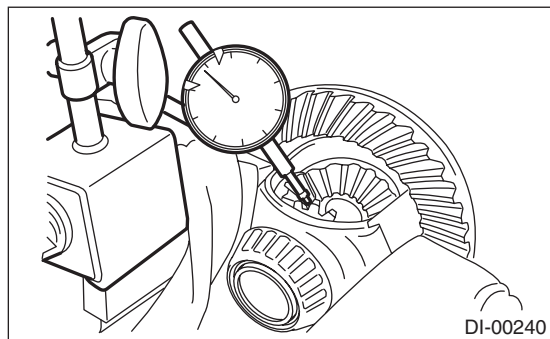

(3) Adjust the backlash as specified by selecting side gear thrust washer.

Side gear thrust washer	
Part No.	Thickness mm (in)
383445201	0.75 — 0.80 (0.0295 — 0.0315)
383445202	0.80 — 0.85 (0.0315 — 0.0335)
383445203	0.85 — 0.90 (0.0335 — 0.0354)

(4) Check the condition of rotation after applying oil to the gear tooth surfaces and washer surfaces.

(5) Drive the pinion shaft lock pin into the differential case.

### NOTE:

Use a new pinion shaft lock pin.

ST 899904100 STRAIGHT PIN REMOVER

13) Install the driven gear to the differential case.

### NOTE:

- Before installing bolts, apply seal material to bolt threads.

### Seal material:

**THREE BOND 1324 (Part No. 004403042) or equivalent**

- Make sure there is no clearance between the differential case and driven gear.
- Tighten opposing bolts in order.

### Tightening torque:

**103 N·m (10.5 kgf·m, 76.0 ft·lb)**

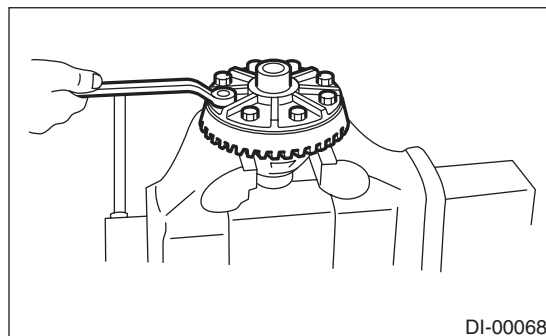

14) Using the ST, press-fit the side bearing to the differential case.

ST 398487700 DRIFT

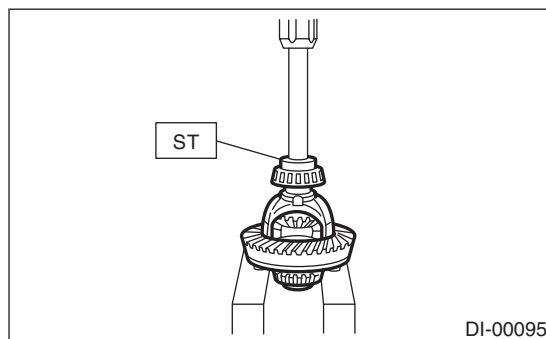

## Rear Differential (T-type)

### DIFFERENTIALS

15) Using the ST, press-fit the side bearing outer race to the side retainer.

#### CAUTION:

**Make sure that the bearing outer races and cones are properly assembled.**

ST 398417700 DRIFT

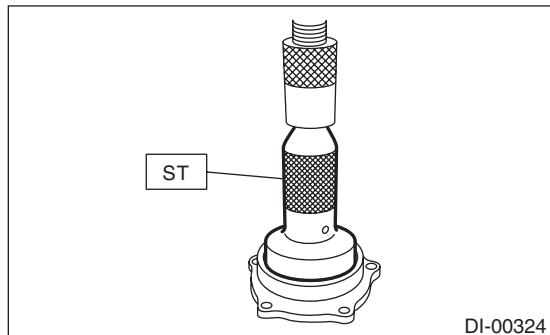

#### 16) Side retainer shim adjustment

(1) The hypoid driven gear backlash and side bearing preload can be adjusted by the side retainer shim thickness.

(2) Install the differential case assembly into differential carrier in the reverse order of disassembly.

#### NOTE:

Be careful not to hit the teeth of hypoid driven gear against the differential carrier.

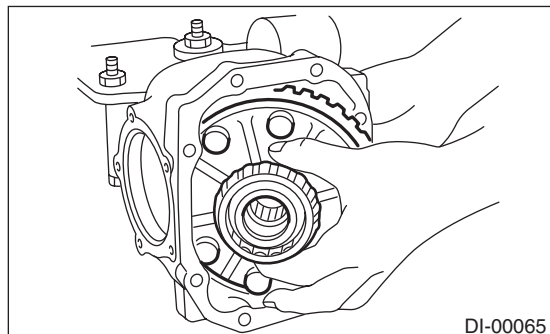

(3) Install the side retainer shim.

#### NOTE:

- Be careful not to mix up the side retainer shim RH and LH.
- Replace broken or corroded side retainer shims with a new part of the same thickness.

Side retainer shim	
Part No.	Thickness mm (in)
383475201	0.20 (0.0079)
383475202	0.25 (0.0098)
383475203	0.30 (0.0118)
383475204	0.40 (0.0157)
383475205	0.50 (0.0197)

(4) Align the arrow mark on the differential carrier with the arrow mark on the side retainer when installing the side retainer.

#### NOTE:

Be careful that the side bearing outer race is not damaged by the bearing roller.

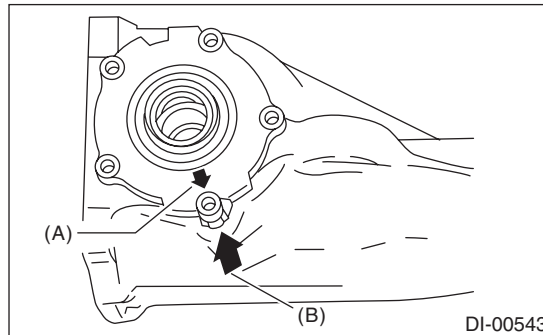

(A) Arrow mark (on the side retainer)

(B) Arrow mark (on the differential carrier)

(5) Tighten the side retainer bolts.

#### Tightening torque:

**10.5 N·m (1.1 kgf·m, 7.7 ft·lb)**

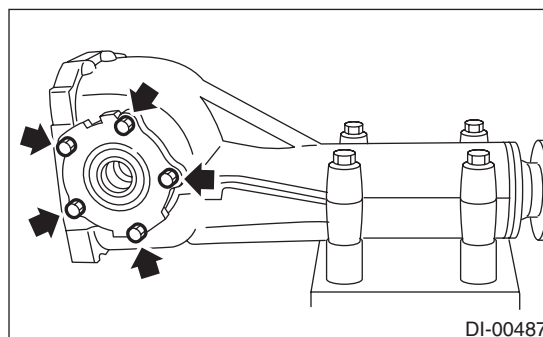

(6) Measure the hypoid driven gear to drive pinion backlash. Set the magnet base on differential carrier. Align the contact point of dial gauge with tooth face of hypoid driven gear, and move hypoid driven gear while holding drive pinion still. Read the value indicated on dial gauge. If the backlash is outside the standard range, adjust the side retainer shim by the following method.

#### •When backlash is less than 0.1 mm (0.004 in):

Reduce the thickness of shim on the back side of the hypoid driven gear and increase the thickness of shims on the teeth side of the hypoid driven gear.

#### •When backlash exceeds 0.2 mm (0.008 in):

Increase the thickness of shim on the back side of the hypoid driven gear and reduce the thickness of shims on the teeth side of the hypoid driven gear.

**Backlash:**

**0.10 — 0.20 mm (0.004 — 0.008 in)**

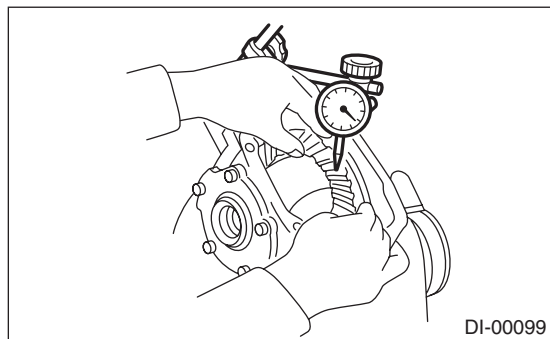

DI-00099

(7) Measure the total preload of the drive pinion. If the total preload is outside the specification range, adjust the thickness of side retainer shims, increasing/reducing both shims by an even amount at a time.

**Total preload:**

**20.7 — 54.4 N (2.1 — 5.5 kgf, 4.7 — 12.2 lbf)**

17) Recheck the hypoid driven gear to drive pinion backlash.

**Backlash:**

**0.10 — 0.20 mm (0.004 — 0.008 in)**

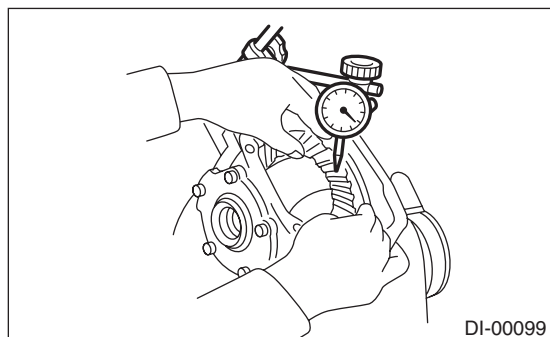

DI-00099

18) Check pinion and hypoid driven gears rotate smoothly and make sure of the hypoid driven gear runout on its back surface. If the hypoid driven gear runout on its back surface exceeds the specification, check for any foreign objects between the hypoid driven gear and differential case, and for any deformation of the differential case or hypoid driven gear.

**Hypoid driven gear back surface runout:**

**0.05 mm (0.002 in)**

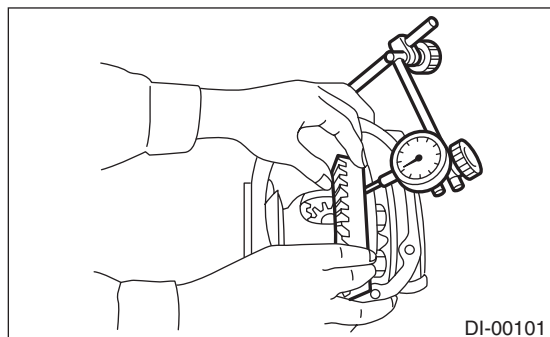

DI-00101

19) Check and adjustment of the tooth contact of hypoid driven gear and drive pinion

(1) Apply lead-free red dye evenly on the both sides of three to four teeth of the hypoid driven gear. Check the contact pattern after rotating the hypoid driven gear several revolutions back and forth until a definite contact pattern appears on the hypoid driven gear.

(2) When the contact pattern is not correct, re-adjust.

**NOTE:**

Be sure to wipe off the lead-free red dye completely after the adjustment is completed.

- Correct tooth contact

**Check item: Tooth contact pattern is slightly shifted toward toe side under no-load rotation. (When driving, it moves towards the heel side.)**

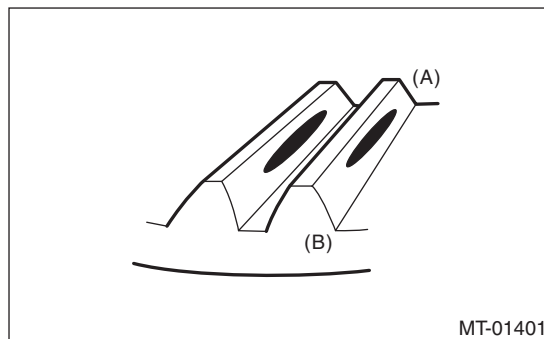

MT-01401

(A) Toe side

(B) Heel side

# Rear Differential (T-type)

## DIFFERENTIALS

- Face contact

**Check item: Backlash is too large.**

Contact pattern

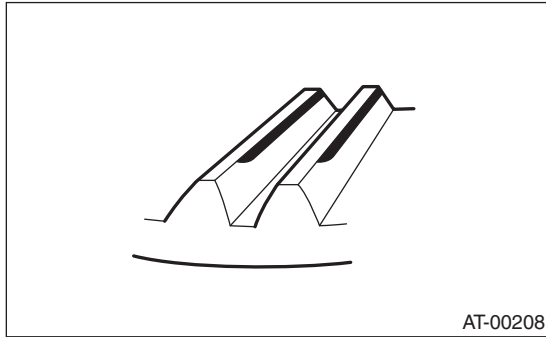

Corrective action: Increase thickness of pinion height adjusting washer according to the procedure for bringing drive pinion close to hypoid driven gear side.

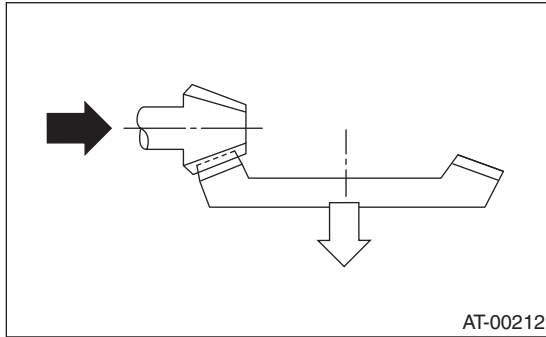

- Flank contact

**Check item: Backlash is too small.**

Contact pattern

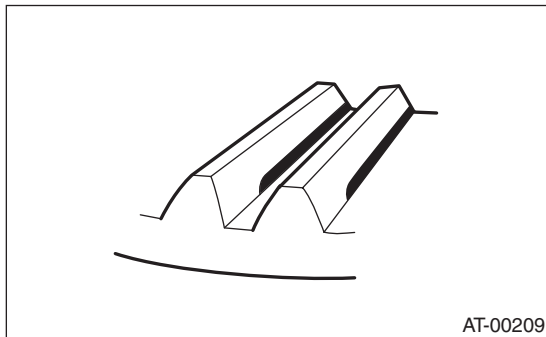

Corrective action: Reduce the thickness of pinion height adjusting washer according to the procedure for bringing drive pinion away from hypoid driven gear.

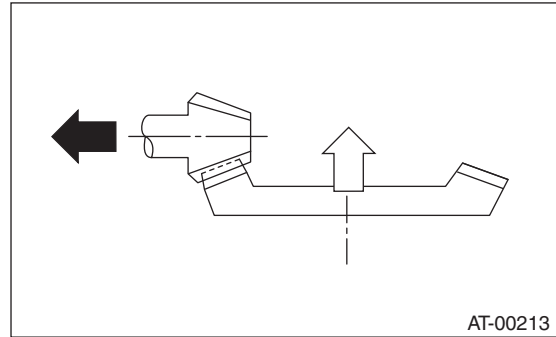

- Toe contact (inside contact)

**Check item: Teeth contact area is too small.**

Contact pattern

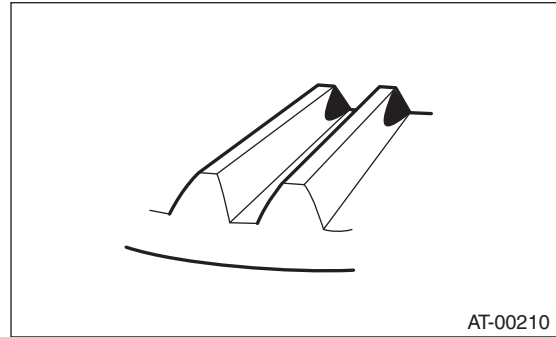

Corrective action: Reduce the thickness of pinion height adjusting washer according to the procedure for bringing drive pinion away from hypoid driven gear.

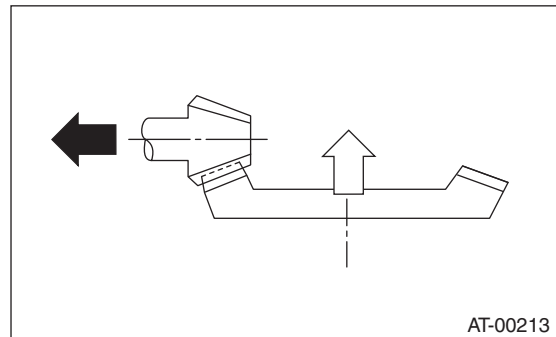

- Heel contact (outside end contact)  
**Check item: Teeth contact area is too small.**  
 Contact pattern

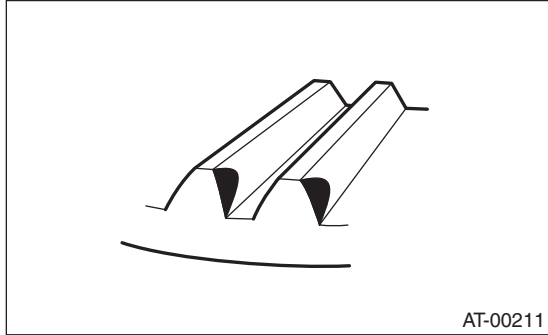

Corrective action: Increase thickness of pinion height adjusting washer according to the procedure for bringing drive pinion close to hypoid driven gear side.

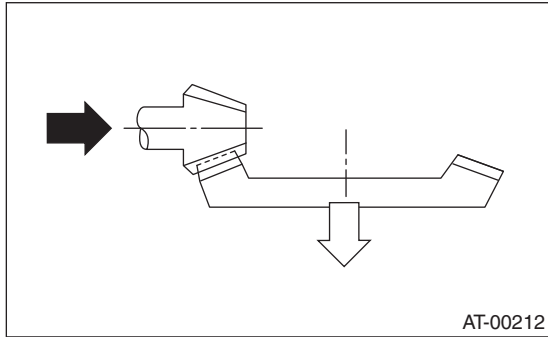

20) If proper tooth contact is not obtained, readjust the drive pinion height by changing the RH and LH side retainer shims and the hypoid gear backlash.

(1) Drive pinion height

- ST1 398507702 DUMMY SHAFT
- ST2 398507701 DIFFERENTIAL CARRIER GAUGE

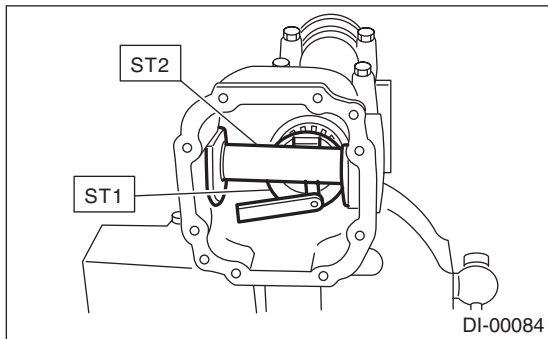

$$T = T_o + N - (H \times 0.01) - 0.20 \text{ mm (0.0079 in)}$$

T	Thickness of pinion height adjusting washer mm (in)	
T <sub>o</sub>	Thickness of washer temporarily inserted mm (in)	
N	Clearance of thickness gauge mm (in)	
H	Figure marked on drive pinion head	
Memo:		

(2) Hypoid gear backlash

**Backlash:**

**0.10 — 0.20 mm (0.004 — 0.008 in)**

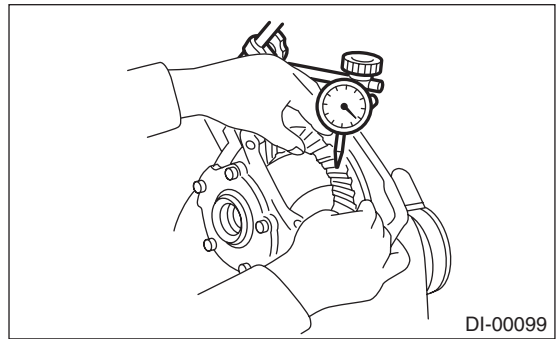

- 21) Remove the RH and LH side retainers.
- 22) Install the O-ring to left and right side retainers.

**NOTE:**

Use new O-rings.

23) Install the oil seal to the side retainers on both sides. <Ref. to DI-58, REPLACEMENT, Rear Differential Side Oil Seal.>

24) Align the arrow mark on the differential carrier with the arrow mark on the side retainer when installing the side retainer.

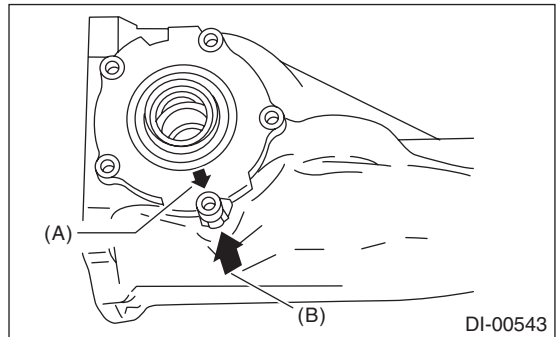

- (A) Arrow mark (on the side retainer)
- (B) Arrow mark (on the differential carrier)



## Rear Differential (T-type)

### DIFFERENTIALS

25) Apply liquid gasket to the bolts indicated by arrows, and tighten the bolts.

**Liquid gasket:**  
**THREE BOND 1110B (Part No. K0879Y0020)**  
**or equivalent**

**Tightening torque:**  
**10.5 N·m (1.1 kgf-m, 7.7 ft-lb)**

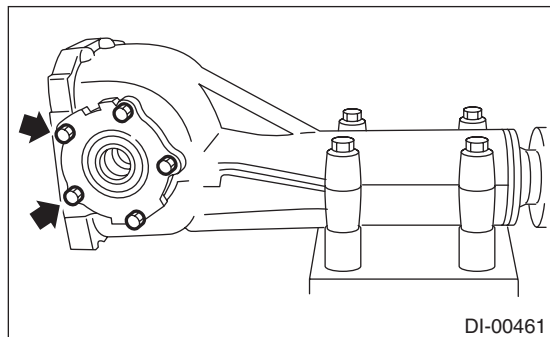

26) Install the gasket and rear cover, and tighten the bolts to specified torque.

**NOTE:**  
Use a new gasket.

**Tightening torque:**  
**29.5 N·m (3.0 kgf-m, 21.8 ft-lb)**

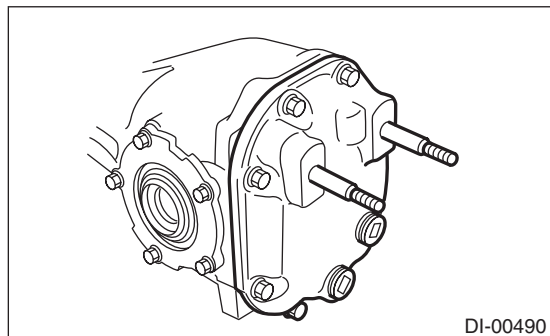

27) Install the air breather cap.

**NOTE:**  
When installing the air breather cap, do not tap section (A). Be sure to tap section (B) to install.

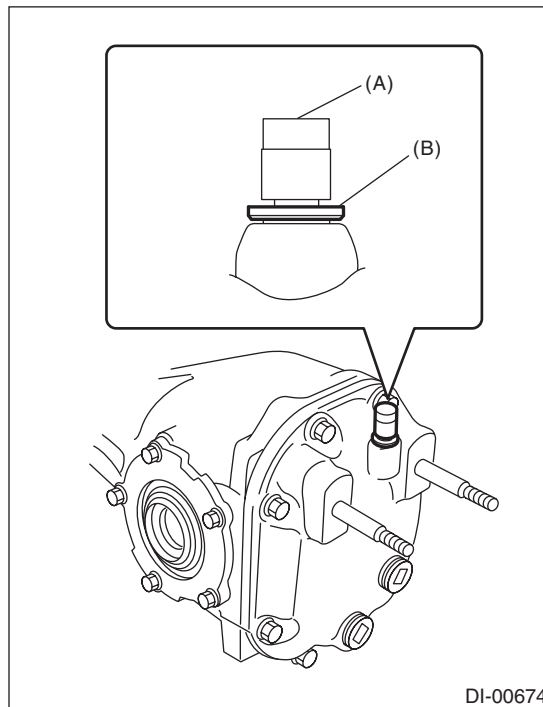

28) Install the drain plug.

**NOTE:**  
Apply liquid gasket to the drain plug.

**Liquid gasket:**  
**THREE BOND 1105 (Part No. 004403010)**  
**or equivalent**

**Tightening torque:**  
**49 N·m (5.0 kgf-m, 36.1 ft-lb)**

29) Install the filler plug.

**NOTE:**  
After installing the rear differential assembly to the vehicle, fill the gear oil, then apply liquid gasket, and tighten to the specified torque. <Ref. to DI-19, REPLACEMENT, Differential Gear Oil.>

**E: INSPECTION**

Wash all the disassembled parts clean, and examine them for wear, damage and other defects. Repair or replace the defective parts as necessary.

**1) Hypoid driven gear and drive pinion**

- If there is evidently an abnormal tooth contact, find out the cause and adjust until the teeth contact correctly. Replace the gear if there is an excessive worn or an incapable adjustment.
- If crack, cutout or seizure is found, replace the parts as a set. Slight damage of some teeth can be corrected by oil stone or the like.

**2) Side gear and pinion mate gear**

- Replace if cracks, scoring or other defects are evident on the tooth surface.
- Replace if thrust washer contact surface is worn or scored. Slight damages of the surface can be corrected by oil stones or equivalent.

**3) Bearing**

Replace if seizure, peeling, wear, rust, dragging during rotation, noise or other defect is evident.

**4) Thrust washer of the side gear and pinion mate gear**

Replace if seized, flawed, abnormally worn or having other defects.

**5) Oil seal**

Replace if deformed or damaged, and at every disassembling.

**6) Differential carrier**

Replace if the bearing bores are worn or damaged.

**7) Differential case**

Replace if sliding surfaces are abnormally worn, burned, or cracked.

**8) Companion flange**

Replace if the oil seal lip contact surface shows cracking.

**1. SIDE GEAR BACKLASH**

Using a dial gauge, check the backlash of side gear.

**Side gear backlash:**

**0.10 — 0.20 mm (0.004 — 0.008 in)**

If the side gear backlash is not within the specified range, select the side gear thrust washer and adjust the side gear backlash as specified.

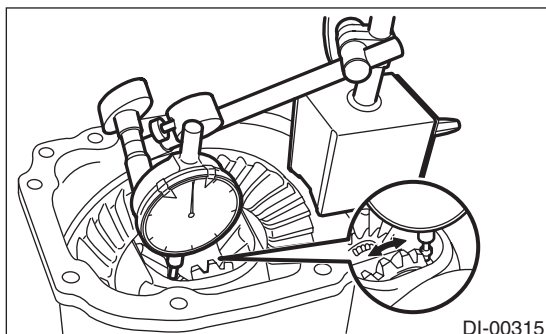

DI-00315

**2. HYPOID DRIVEN GEAR BACKLASH**

Using a dial gauge, check the backlash of hypoid driven gear.

**Hypoid driven gear backlash:**

**0.10 — 0.20 mm (0.004 — 0.008 in)**

If the hypoid driven gear backlash is outside the specification range, adjust the side bearing preload and repair if necessary.

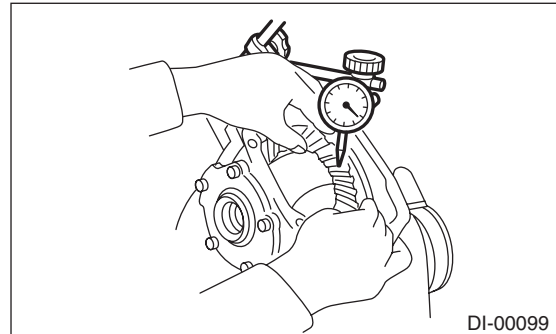

DI-00099

**3. HYPOID DRIVEN GEAR RUNOUT ON ITS BACK SURFACE**

Using a dial gauge, check the hypoid driven gear back surface runout.

**Hypoid driven gear back surface runout:**

**0.05 mm (0.002 in)**

If the hypoid driven gear runout on its back surface exceeds the limit, replace the hypoid driven gear.

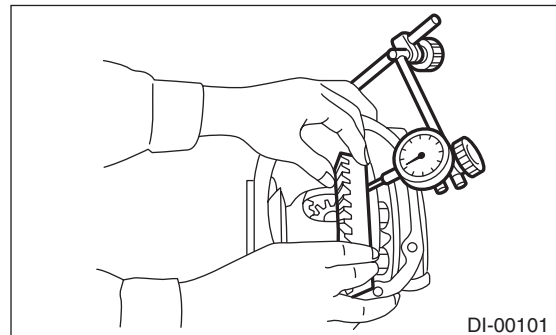

DI-00101

**4. TOOTH CONTACT BETWEEN HYPOID DRIVEN GEAR AND DRIVE PINION**

Inspect the tooth contact between the hypoid driven gear and drive pinion. <Ref. to DI-28, ASSEMBLY, Rear Differential (T-type).>

# Rear Differential (T-type)

## DIFFERENTIALS

### 5. TOTAL PRELOAD

Using a spring scale, check the total preload.

#### **Total preload:**

**20.7 — 54.4 N (2.1 — 5.5 kgf, 4.7 — 12.2 lb)**

If the total preload is not within the specified range, adjust the side retainer shim.

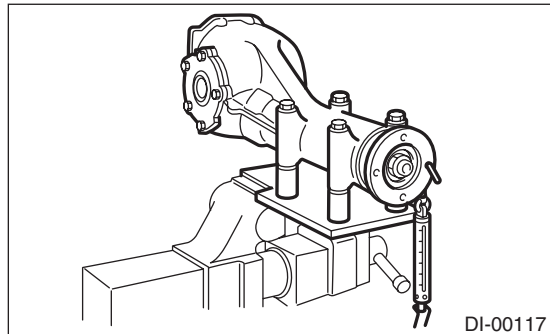

### 6. COMPANION FLANGE

1) If rust or dirt is attached to the companion flange, remove them.

2) Set a dial gauge at a companion flange surface (mating surface of propeller shaft and companion flange), and then measure the companion flange runout.

#### **Limit of runout:**

**0.08 mm (0.003 in)**

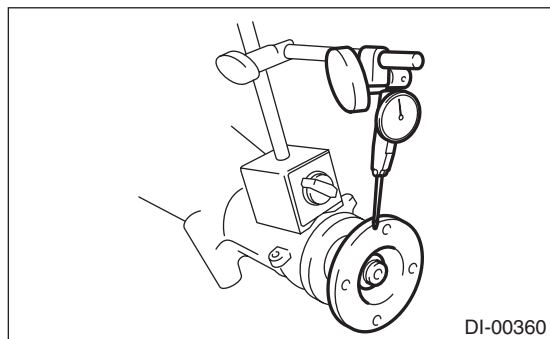

3) Set the gauge inside of the companion flange, and measure the runout.

#### **Limit of runout:**

**0.08 mm (0.003 in)**

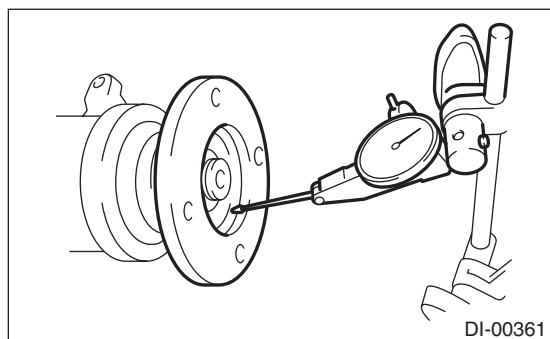

4) If either runout exceeds the limit, move the phase of companion flange and drive pinion 90° each, and find the point where the runout is within the limit.

5) If the runout exceeds the limit even after changing the phase, replace the companion flange and recheck the runout.

6) If the runout exceeds the limit after replacing the companion flange, the drive pinion may be assembled incorrectly or bearing is faulty.

## F: ADJUSTMENT

### 1. SIDE GEAR BACKLASH

Adjust the side gear backlash. <Ref. to DI-28, ASSEMBLY, Rear Differential (T-type).>

### 2. HYPOID DRIVEN GEAR BACKLASH

Adjust hypoid driven gear backlash. <Ref. to DI-28, ASSEMBLY, Rear Differential (T-type).>

### 3. TOOTH CONTACT BETWEEN HYPOID DRIVEN GEAR AND DRIVE PINION

Adjust the tooth contact between hypoid driven gear and drive pinion gear. <Ref. to DI-28, ASSEMBLY, Rear Differential (T-type).>

### 4. TOTAL PRELOAD

Adjust the side retainer shim. <Ref. to DI-28, ASSEMBLY, Rear Differential (T-type).>