

## 3. Front Axle

### A: REMOVAL

- 1) Lift up the vehicle, and then remove the front wheels.
- 2) Remove the nut - axle.

#### CAUTION:

**Do not loosen the nut - axle while the front axle is loaded. Doing so may damage the hub unit COMPL.**

- (1) Lift the crimped section of the nut - axle.
- (2) Remove the nut - axle using a socket wrench while depressing the brake pedal.

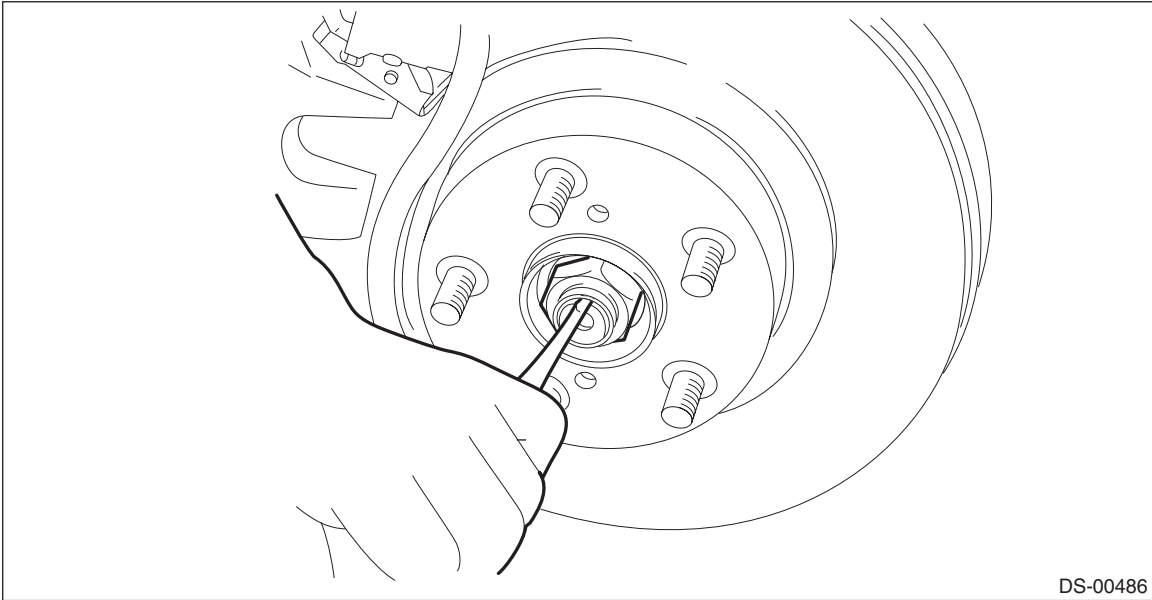

- 3) Remove the caliper body assembly from the housing assembly - front axle.
  - (1) Remove the mounting bolts, and then remove the caliper body assembly.
  - (2) Prepare wiring harnesses etc. to be discarded, and suspend the caliper body assembly from the strut assembly.

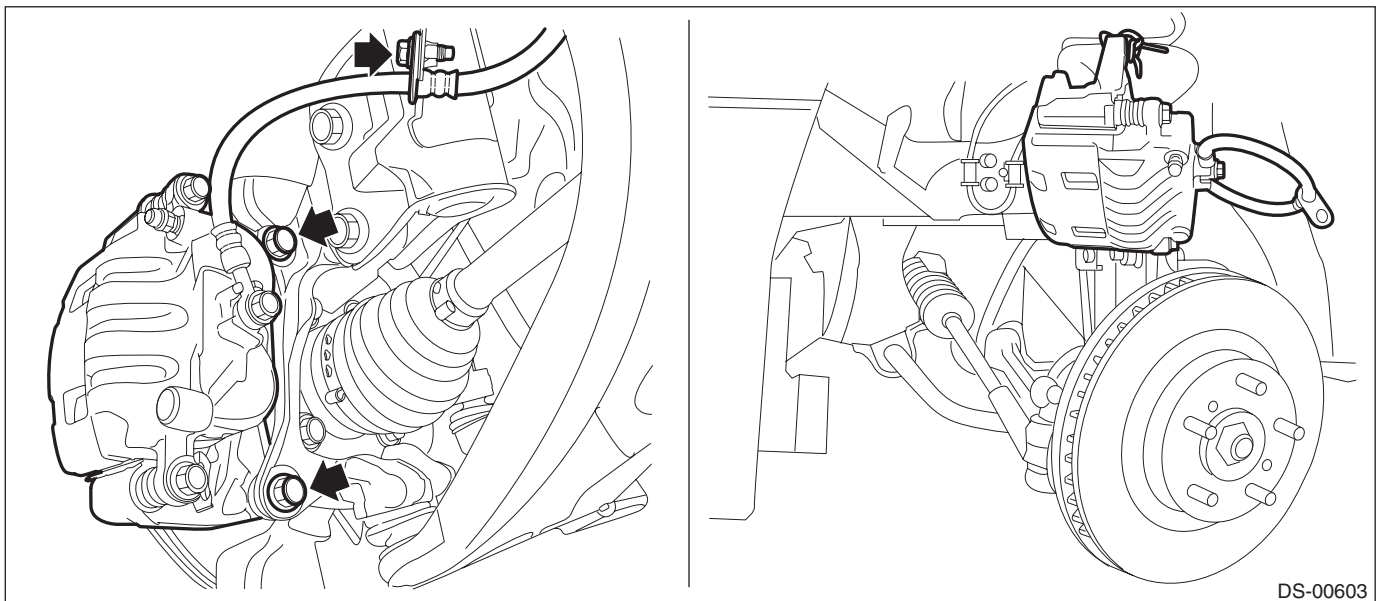

# Front Axle

## DRIVE SHAFT SYSTEM

4) Remove the disc rotor.

### NOTE:

When the disc rotor is difficult to be removed from the hub unit COMPL - front axle, screw in 8 mm (0.31 in) bolt to the threaded part of the disc rotor (A), and remove the disc rotor.

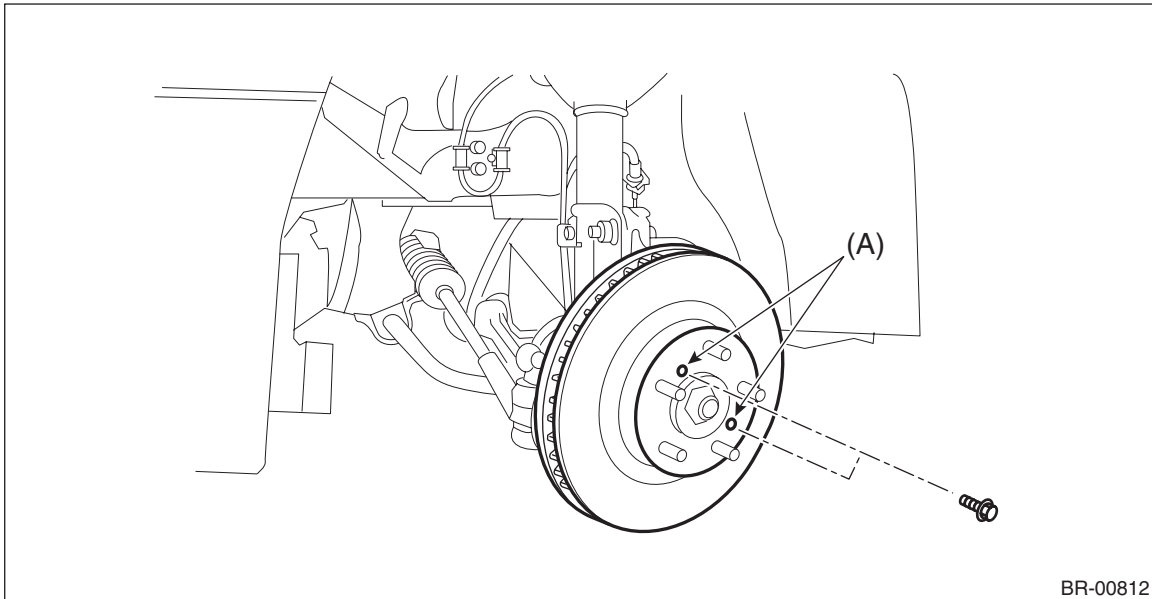

5) Disconnect the tie-rod end.

- (1) Pull out the cotter pin (a).
- (2) Remove the castle nut (b).
- (3) Using a tie-rod ball joint puller, remove the tie-rod end (c).

### CAUTION:

Be careful not to damage the boot of the joint.

### Preparation tool:

*Tie-rod ball joint puller*

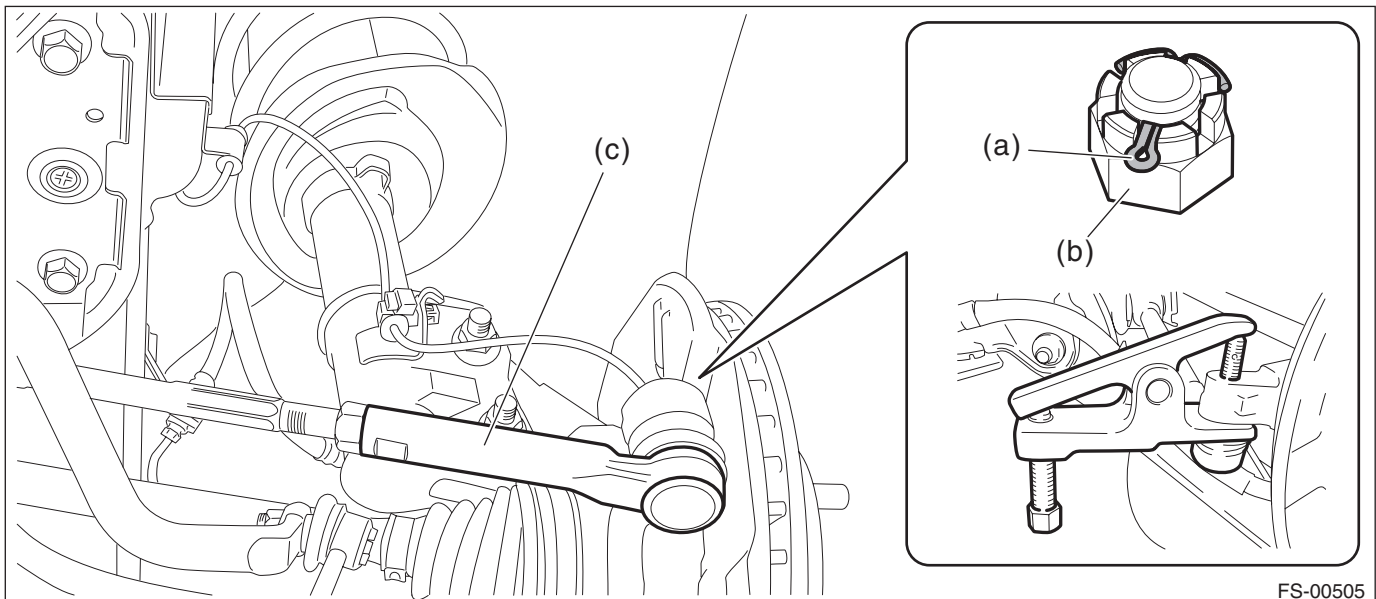

6) Remove the bolts, and remove the front ABS wheel speed sensor.

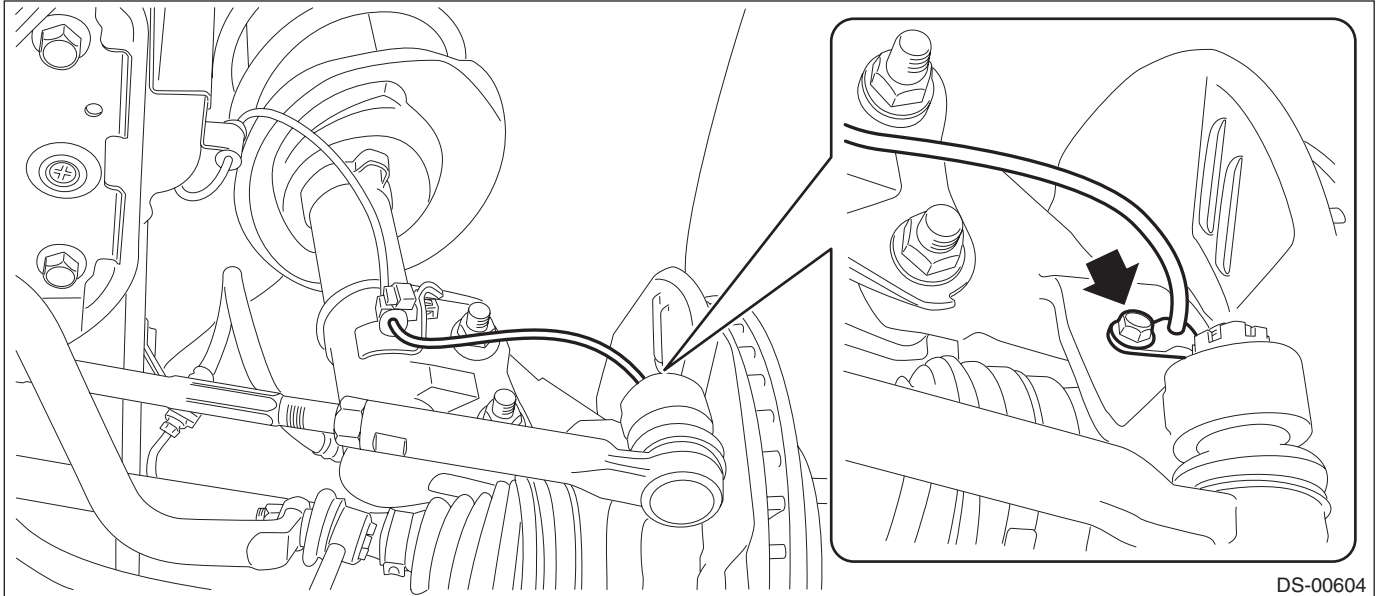

7) Remove the stabilizer link and ball joint.

**CAUTION:**

**Be careful not to damage the boot of the joint.**

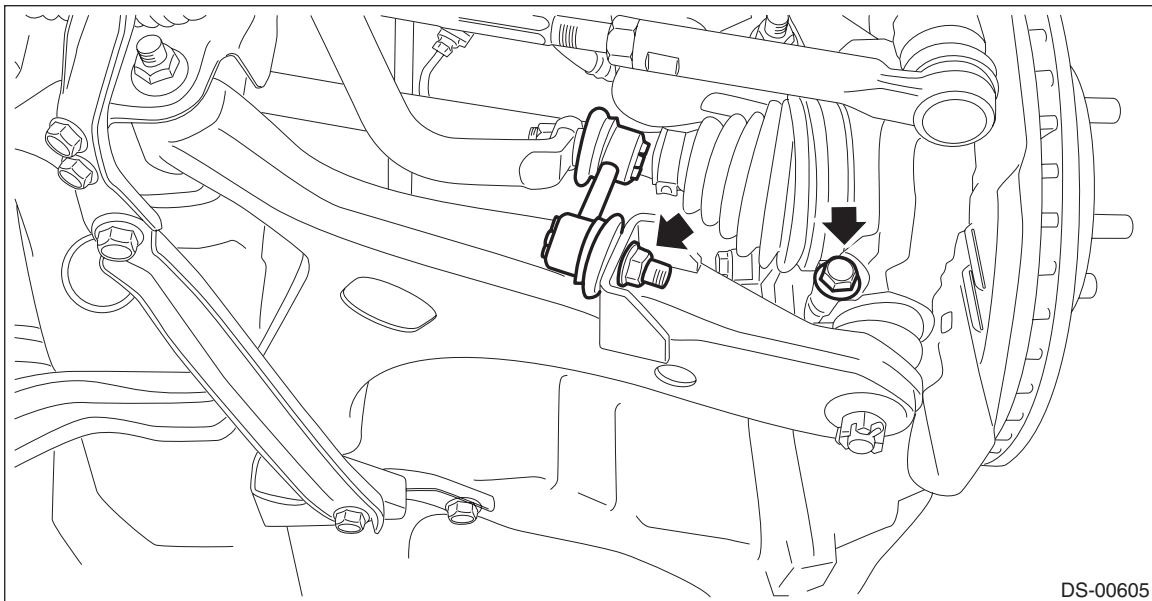

8) Using a crowbar, remove the front axle shaft from the transmission.

**CAUTION:**

**Be careful not to allow the bar to damage holder area.**

## Front Axle

### DRIVE SHAFT SYSTEM

9) Remove the front axle shaft assembly from the hub unit COMPL - front axle.

#### Preparation tool:

**ST1: AXLE SHAFT PULLER (926470000)**

**ST2: AXLE SHAFT PULLER PLATE (28099PA110)**

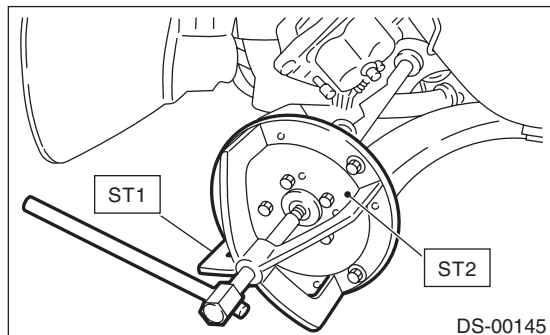

#### NOTE:

If it is hard to remove, use the ST.

10) Remove the housing assembly - front axle.

(1) Place an alignment mark (a) on the adjusting bolt and the strut.

(2) Remove the adjusting bolts and flange bolts for the strut assembly, and then remove the housing assembly - front axle.

#### CAUTION:

- While holding the head of the adjusting bolt, loosen the flange nut.
- Be careful of the weight of the housing assembly - front axle.
- Be careful not to damage the spline portion of the axle shaft.

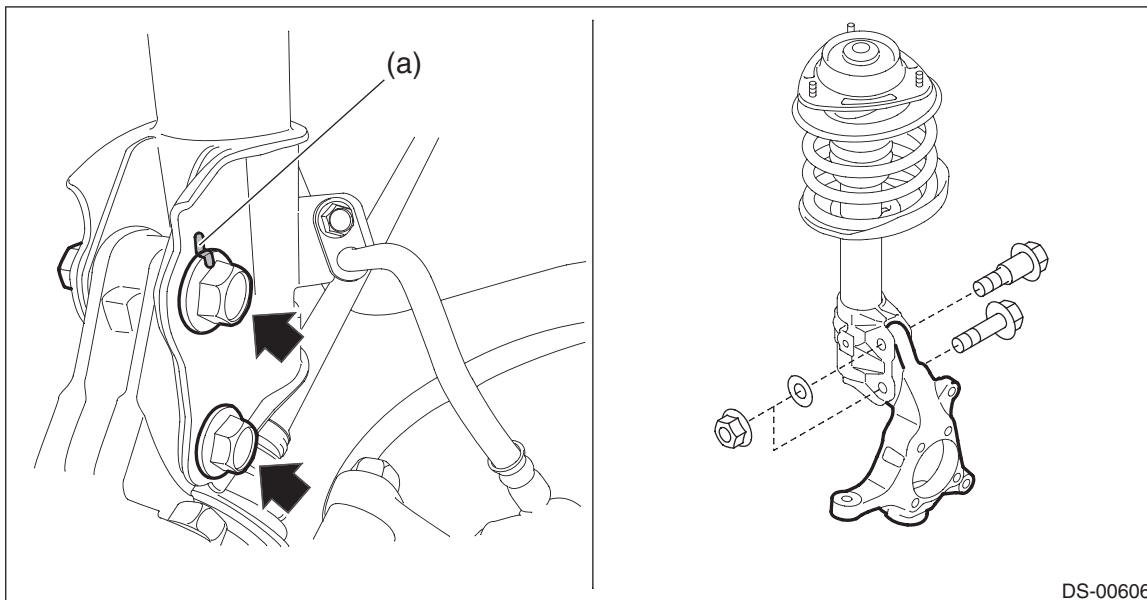

11) For removal of the hub unit COMPL - front axle, refer to "Front Hub Unit Bearing". <Ref. to DS-25, REMOVAL, Front Hub Unit Bearing.>

## B: INSTALLATION

1) Install the front axle shaft assembly.

### CAUTION:

- Do not tap the axle shaft using a hammer when installing axle shaft assembly.
- Use new nut - axle.

(1) Insert the axle shaft assembly into the hub spline, and pull in the axle shaft assembly into specified position.

(2) Temporarily tighten the nut - axle.

2) Install the ball joint assembly to the housing assembly - front axle.

### CAUTION:

- Before tightening, make sure the bottom surface of the housing assembly - front axle and the stepped section of ball joint are in contact.
- Be careful not to damage the boot of the joint.

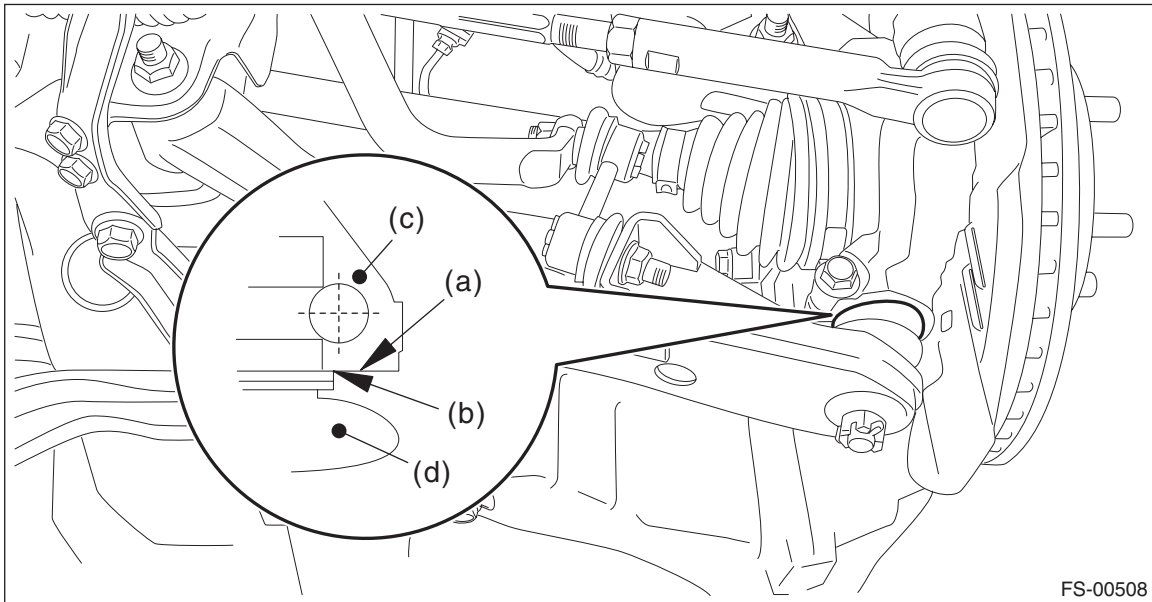

FS-00508

- (a) Bottom surface of housing ASSY - front axle      (c) Housing ASSY - front axle      (d) Ball joint ASSY  
 (b) Raised section of ball joint

### Tightening torque:

**50 N·m (5.10 kgf-m, 36.9 ft-lb)**

3) Install the front ABS wheel speed sensor.

### Tightening torque:

**7.5 N·m (0.76 kgf-m, 5.5 ft-lb)**

4) Install the disc rotor.

5) Install the caliper body assembly.

### Tightening torque:

**80 N·m (8.16 kgf-m, 59.0 ft-lb)**

6) Install the stabilizer link assembly.

- Except for XV model

### Tightening torque:

**38 N·m (3.87 kgf-m, 28.0 ft-lb)**

- XV model

### Tightening torque:

**60 N·m (6.12 kgf-m, 44.3 ft-lb)**

## Front Axle

### DRIVE SHAFT SYSTEM

---

7) Connect the tie-rod ends.

- (1) Connect the tie-rod ends to the housing assembly - front axle.
- (2) Tighten the castle nuts to the specified torque.

**CAUTION:**

**When connecting the tie-rod, do not hit the cap at bottom of tie-rod end with a hammer.**

**Tightening torque:**

**27 N·m (2.75 kgf-m, 19.9 ft-lb)**

- (3) Tighten the castle nut within the range of 60° so that the cotter pin hole and cutout portion of the castle nut are aligned.
- (4) Insert the cotter pin, and bend the tip of the pin to fix it.

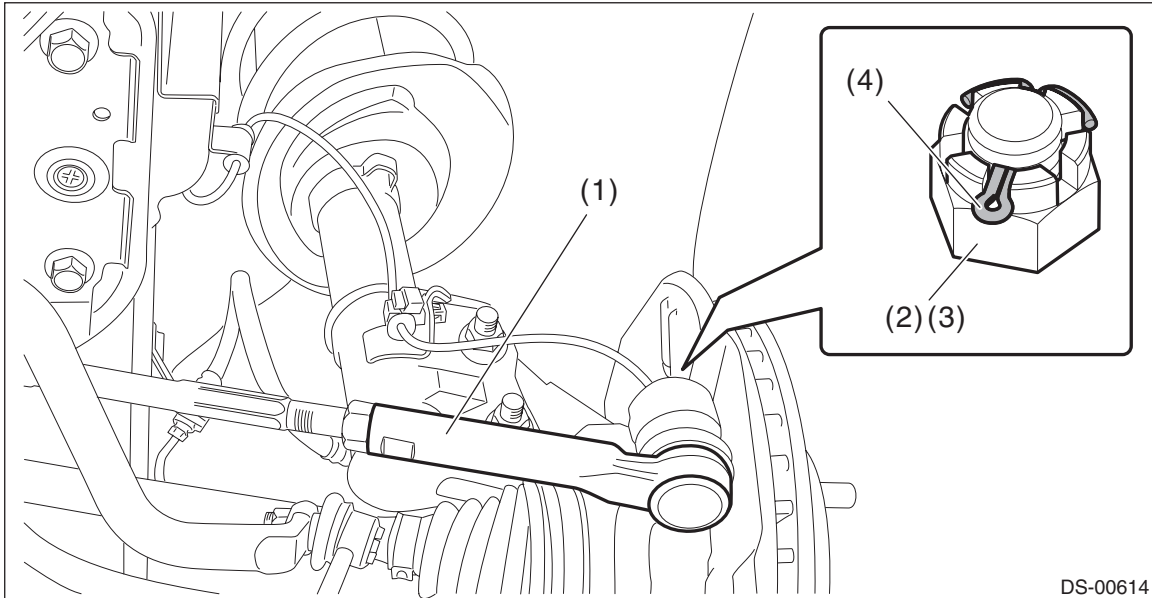

8) While depressing the brake pedal, tighten a new nut - axle to the specified torque and lock it securely.

**CAUTION:**

**Do not load the front axle before tightening the nut - axle. Doing so may damage the hub unit COMPL.**

**Tightening torque:**

**220 N·m (22.43 kgf-m, 162.3 ft-lb)**

9) Inspect the lean of axis direction using a dial gauge. Replace the hub unit COMPL - front axle if the play exceeds the limit.

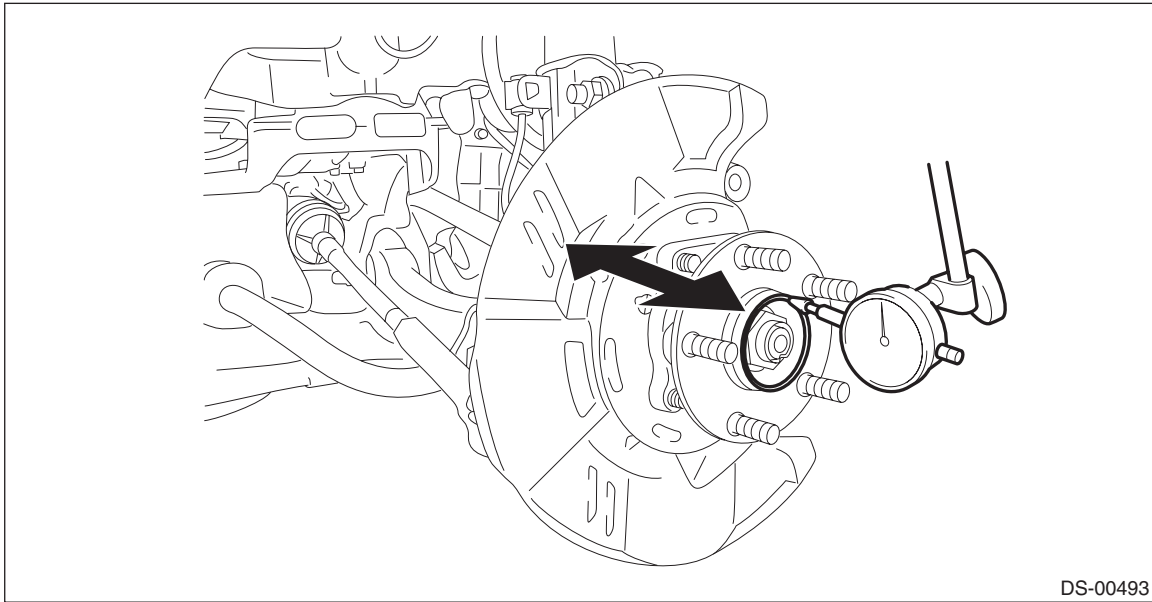

**Service limit:**

**Maximum: 0.05 mm (0.0020 in)**

10) After tightening the nut - axle, lock it securely.

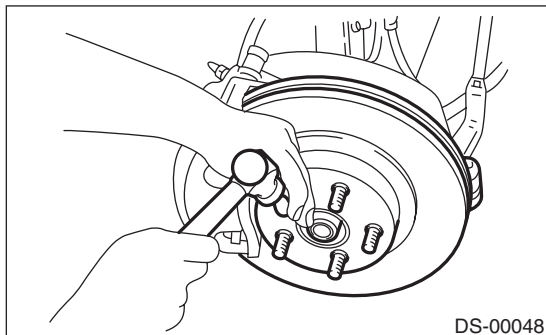

11) Install the front wheels, and perform the following inspections.

**Tightening torque:**

**120 N·m (12.24 kgf-m, 88.5 ft-lb)**

1. Check the wheels for smooth rotation.

## Front Axle

### DRIVE SHAFT SYSTEM

---

2. Check that there is no play by moving the upper and lower portions of front tire in an axial direction with the brake pedal released.

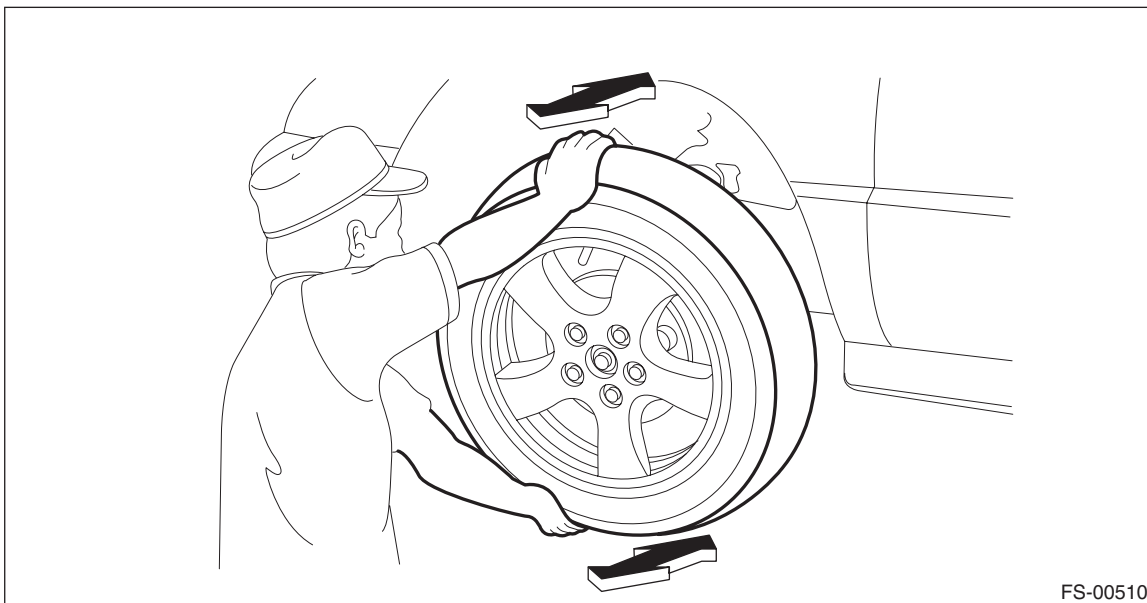

- **Play exists** → Check the hub unit COMPL - front axle. <Ref. to DS-34, INSPECTION, Front Hub Unit Bearing.>
3. Check that there is no play by moving the upper and lower portions of front tire in an axial direction with the brake pedal depressed.
- **Play exists** → Replace the ball joint assembly. <Ref. to FS-32, REMOVAL, Front Ball Joint.>
- 12) Inspect the wheel alignment and adjust if necessary.
- Inspection: <Ref. to FS-7, INSPECTION, Wheel Alignment.>
  - Adjustment: <Ref. to FS-12, ADJUSTMENT, Wheel Alignment.>

#### **CAUTION:**

**When the wheel alignment has been adjusted, perform “VDC sensor midpoint setting mode.”**

13) Perform reinitialization of the auto headlight beam leveler system. (Model with auto headlight beam leveler) <Ref. to LI-17, PROCEDURE, Auto Headlight Beam Leveler System.>