

Rear Hub Unit Bearing

DRIVE SHAFT SYSTEM

6. Rear Hub Unit Bearing

A: REMOVAL

- 1) Lift up the vehicle, and then remove the rear wheels.
- 2) Remove the nut - axle.

CAUTION:

Do not loosen the nut - axle while the rear axle is loaded. Doing so may damage the hub unit COMPL.

- (1) Lift the crimped section of the nut - axle.
- (2) Remove the nut - axle using a socket wrench while depressing the brake pedal.

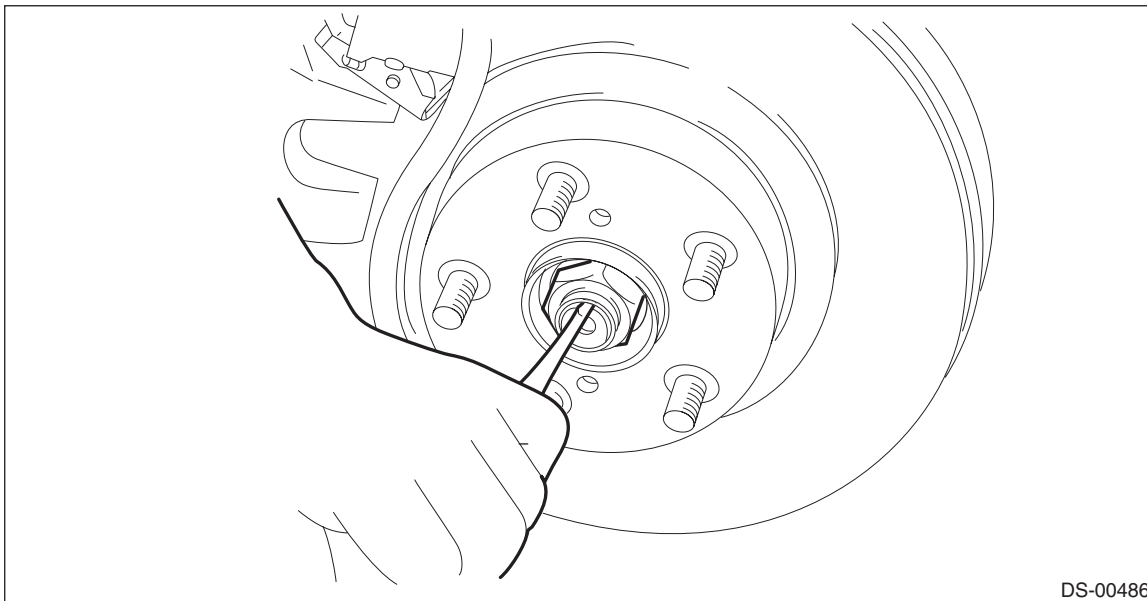

DS-00486

- 3) Remove the rear ABS wheel speed sensor from the rear axle housing.
 - (1) Remove the bolts, and remove the rear ABS wheel speed sensor.
 - (2) Remove the rear ABS wheel speed sensor harness from the upper arm.

CAUTION:

- Be careful not to damage the sensor.
- Do not apply excessive force to the sensor harness.
 - Except for XV model: Remove the harness clamp clip.

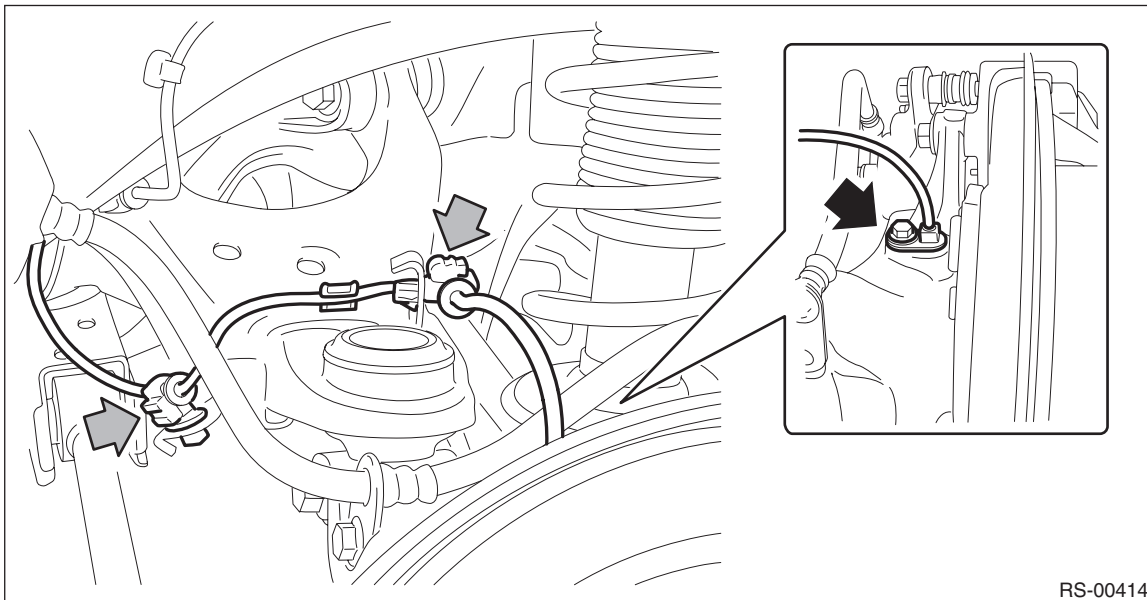

RS-00414

- XV model: Remove the bolts and remove the sensor bracket.

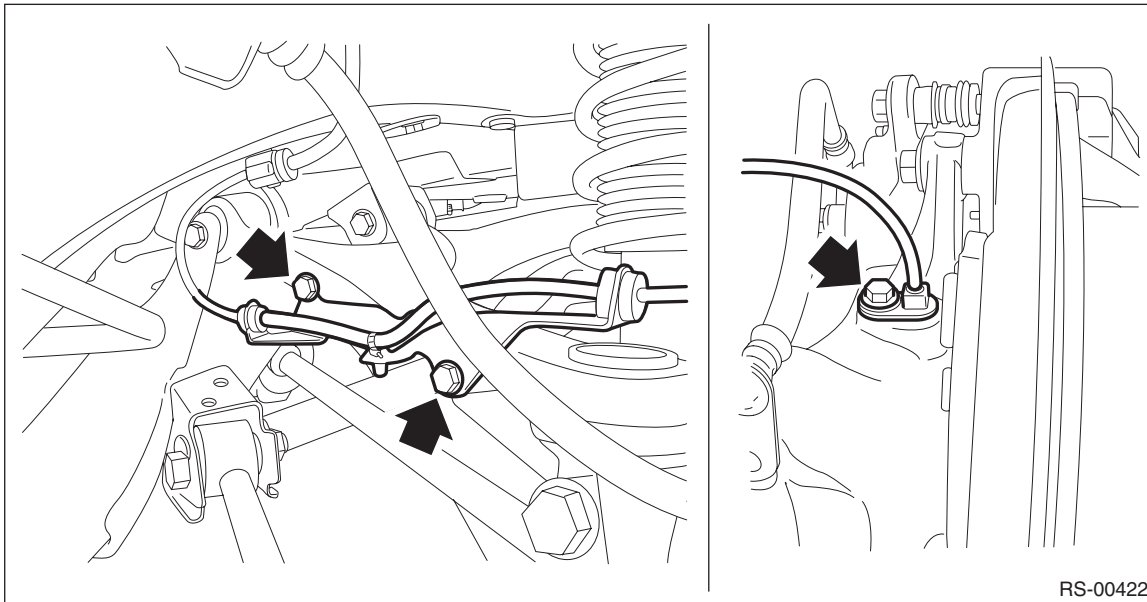

- 4) Remove the caliper body assembly from the housing assembly - rear axle.
(1) Remove the bolts and then remove the brake hose bracket and caliper body assembly.

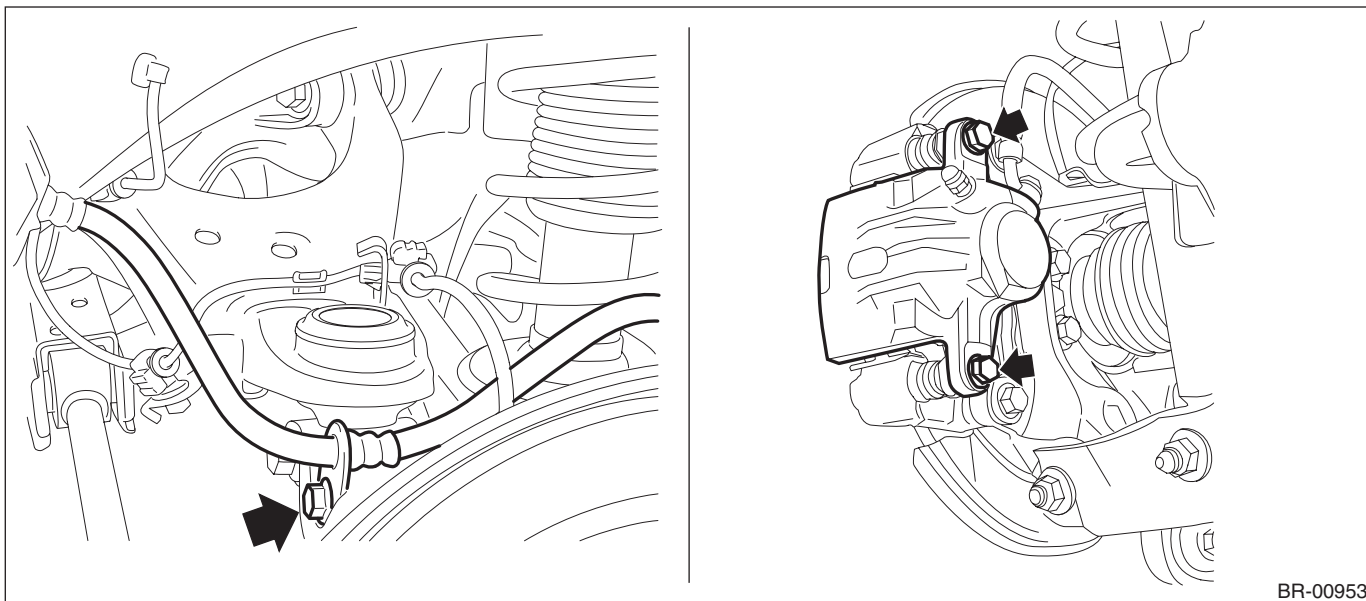

Rear Hub Unit Bearing

DRIVE SHAFT SYSTEM

(2) Prepare wiring harnesses etc. to be discarded, and suspend the caliper body assembly from the strut assembly.

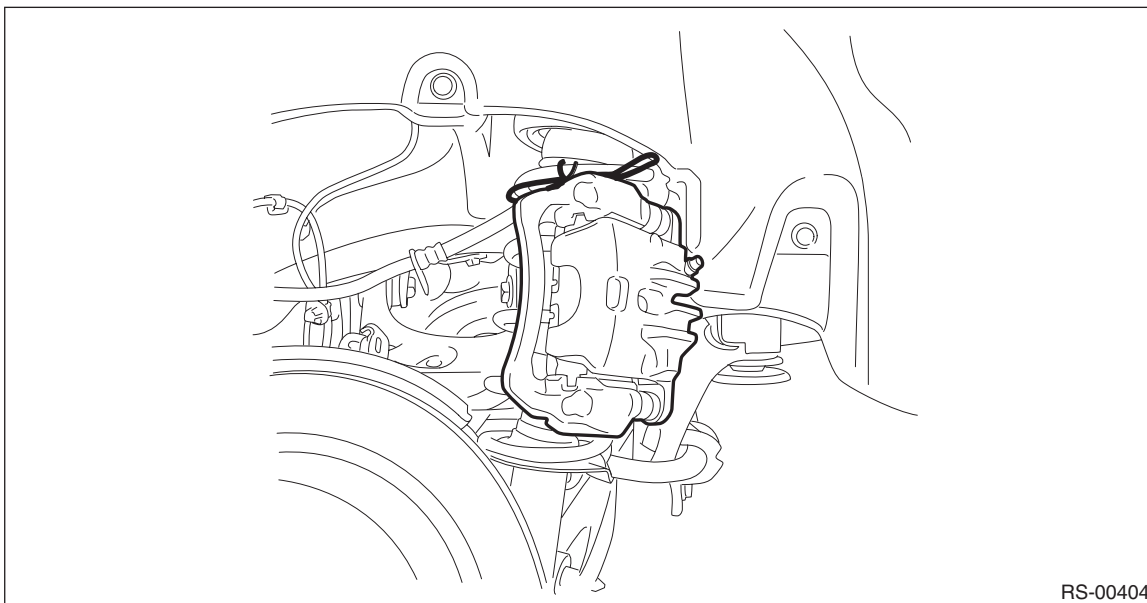

5) Remove the rear disc rotor.

NOTE:

If it is difficult to remove the disc rotor, perform the following two methods in order.

1. Remove the adjusting hole cover (A) for the disc rotor, and rotate the adjuster assembly - rear brake using a flat tip screwdriver until the brake shoe moves far enough from the disc rotor.

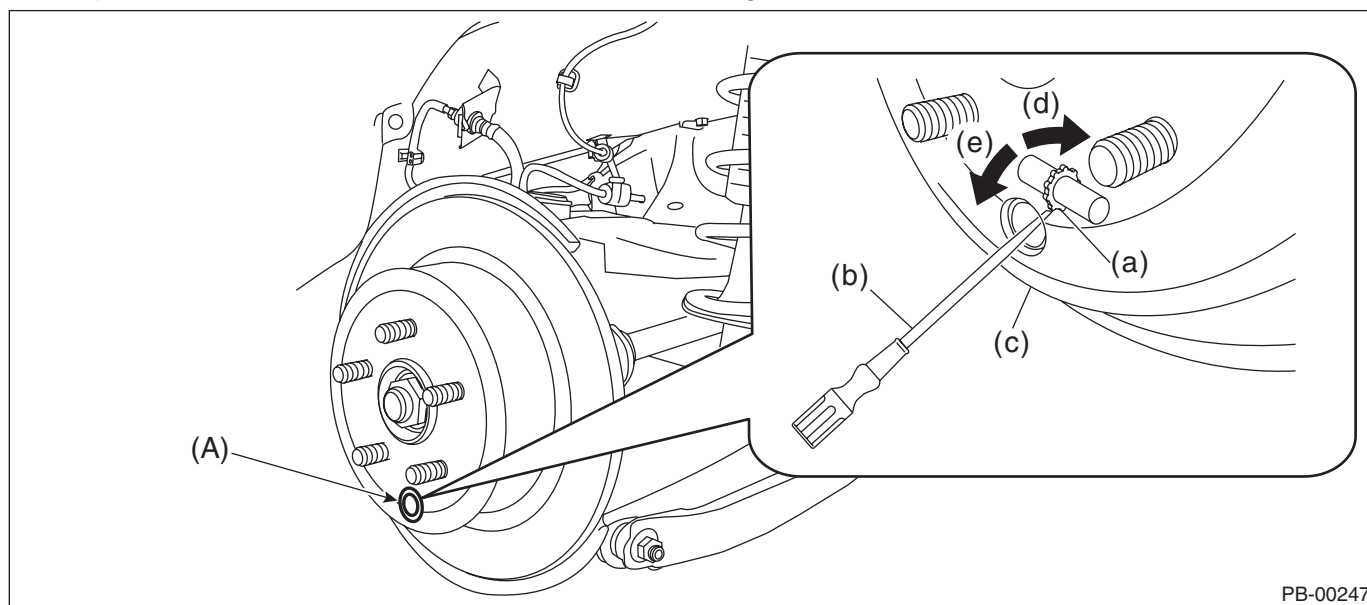

(a) Adjuster ASSY - rear brake

(c) Disc rotor

(e) Shorten the adjuster ASSY - rear brake

(b) Flat tip screwdriver

(d) Extend the adjuster ASSY - rear brake

Rear Hub Unit Bearing

DRIVE SHAFT SYSTEM

2. When the disc rotor is difficult to be removed from the hub unit COMPL - rear axle, screw in 8 mm (0.31 in) bolt to the threaded part of the disc rotor (A), and remove the disc rotor.

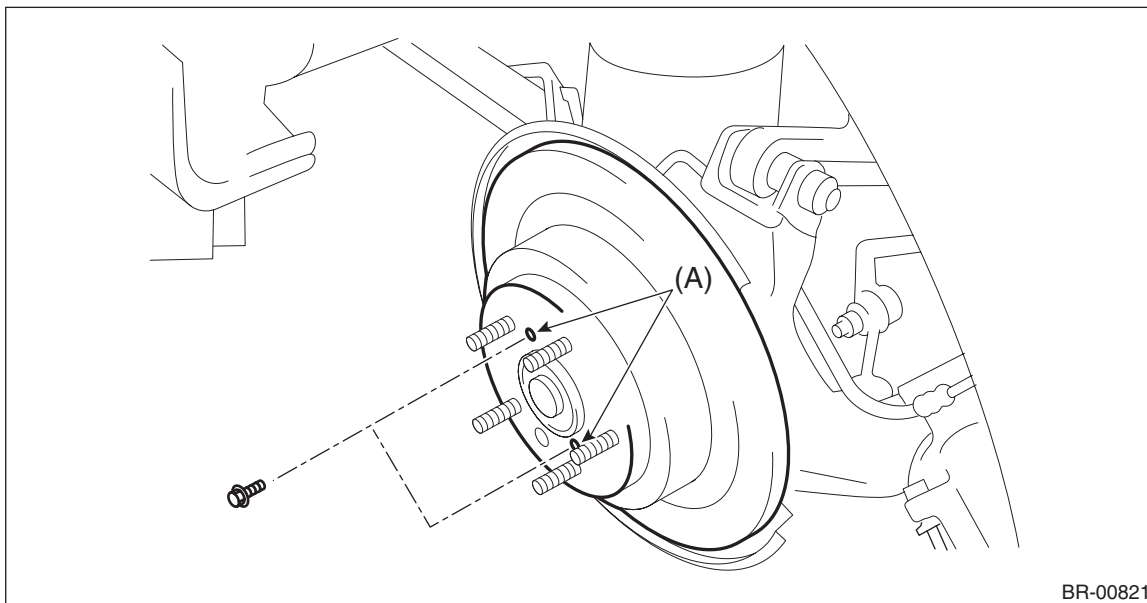

BR-00821

6) Remove the bolts from the housing assembly - rear axle, and then remove the hub unit COMPL - rear axle.

CAUTION:

- Be careful not to damage the magnetic encoder.
- Do not get closer the tool which charged magnetism to magnetic encoder.

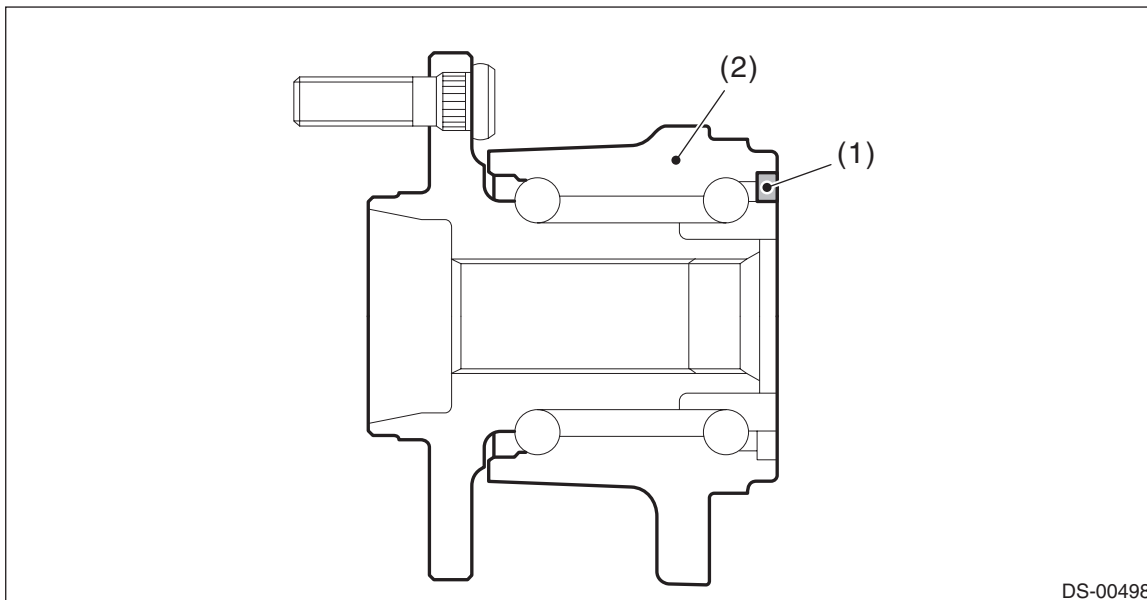

DS-00498

(1) Magnetic encoder

(2) Hub unit COMPL - rear axle

Rear Hub Unit Bearing

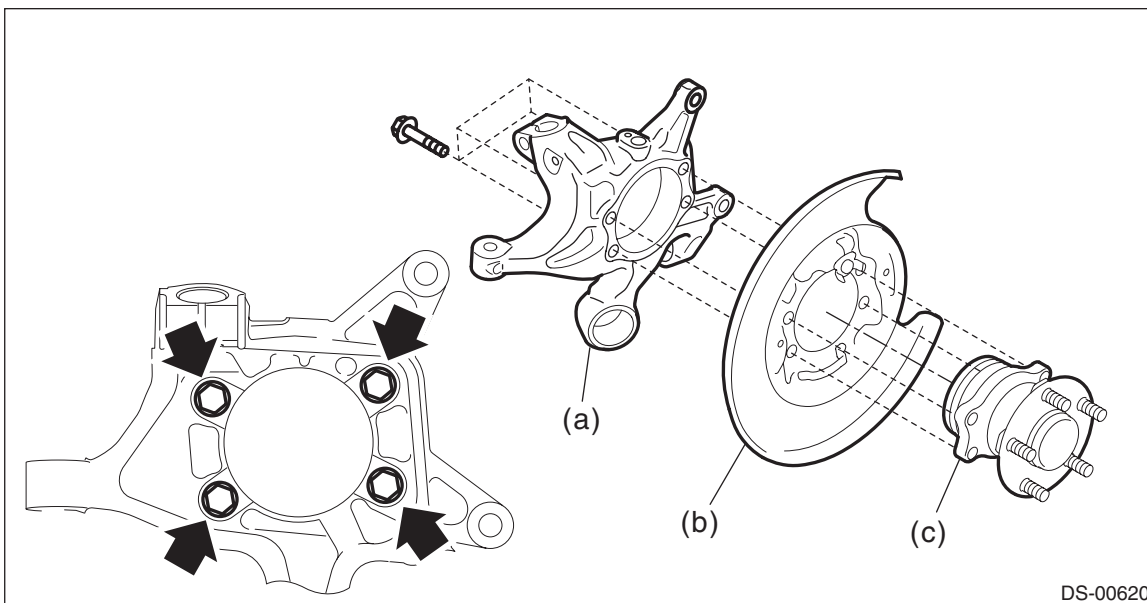

(a) Housing ASSY - rear axle

(b) Back plate - rear brake

(c) Hub unit COMPL - rear axle

NOTE:

If it is hard to remove, use the ST.

Preparation tool:

ST1: AXLE SHAFT PULLER (926470000)

ST2: AXLE SHAFT PULLER PLATE (28099PA110)

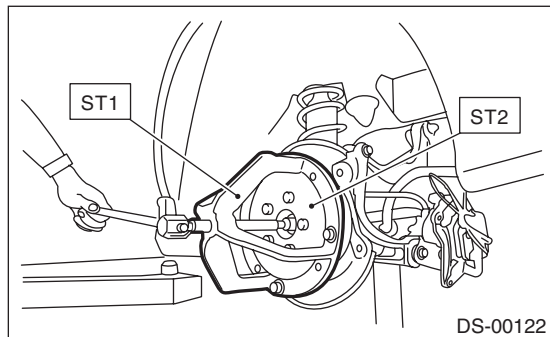

B: INSTALLATION

1) Place the back plate - rear brake between the housing assembly - rear axle and the hub unit COMPL - rear axle, and tighten the bolt.

CAUTION:

- Be careful not to damage the magnetic encoder.
- Do not get closer the tool which charged magnetism to magnetic encoder.

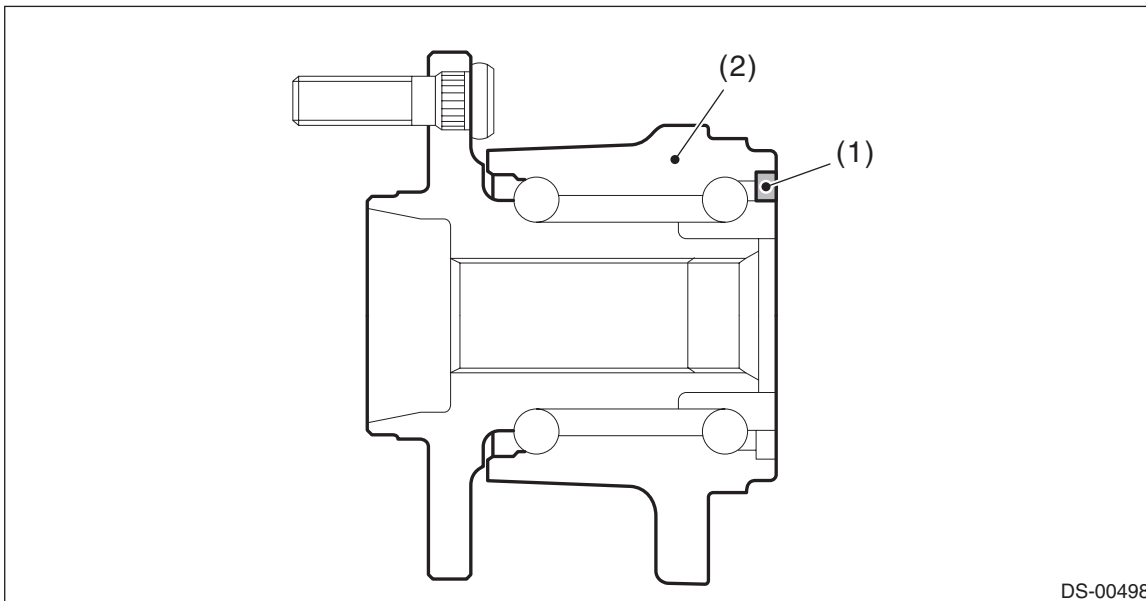

DS-00498

(1) Magnetic encoder

(2) Hub unit COMPL - rear axle

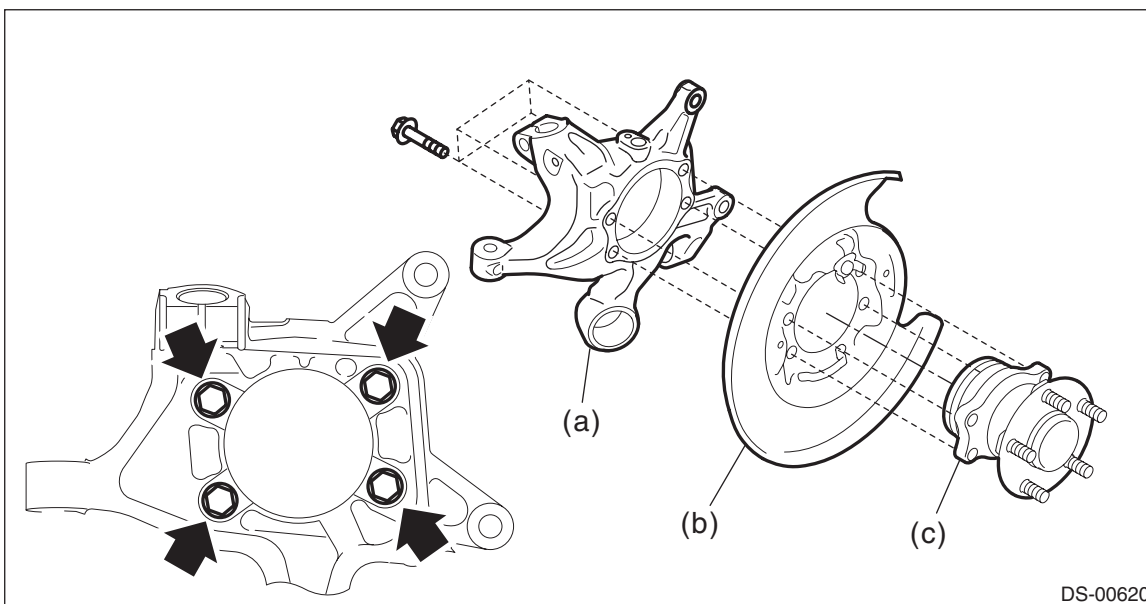

DS-00620

(a) Housing ASSY - rear axle

(b) Back plate - rear brake

(c) Hub unit COMPL - rear axle

Tightening torque:

65 N·m (6.63 kgf·m, 47.9 ft·lb)

Rear Hub Unit Bearing

DRIVE SHAFT SYSTEM

2) Install the rear axle shaft assembly.

CAUTION:

- Do not tap the axle shaft using a hammer when installing axle shaft assembly.
- Use new nut - axle.

(1) Insert the axle shaft assembly into the hub spline, and pull in the axle shaft assembly into specified position.

(2) Temporarily tighten the nut - axle.

3) Install the disc rotor to the hub unit COMPL - rear axle.

4) Install the caliper body assembly to the housing assembly - rear axle.

Tightening torque:

66 N·m (6.73 kgf-m, 48.7 ft-lb)

5) Install the rear ABS wheel speed sensor.

Tightening torque:

7.5 N·m (0.76 kgf-m, 5.5 ft-lb)

6) While depressing the brake pedal, tighten new nuts - axle to the specified torque.

CAUTION:

Do not load the rear axle before tightening the nut - axle. Doing so may damage the hub unit COMPL.

Tightening torque:

190 N·m (19.37 kgf-m, 140.1 ft-lb)

7) Inspect the lean of axis direction using a dial gauge. Replace the hub unit COMPL - rear axle if the play exceeds the limit.

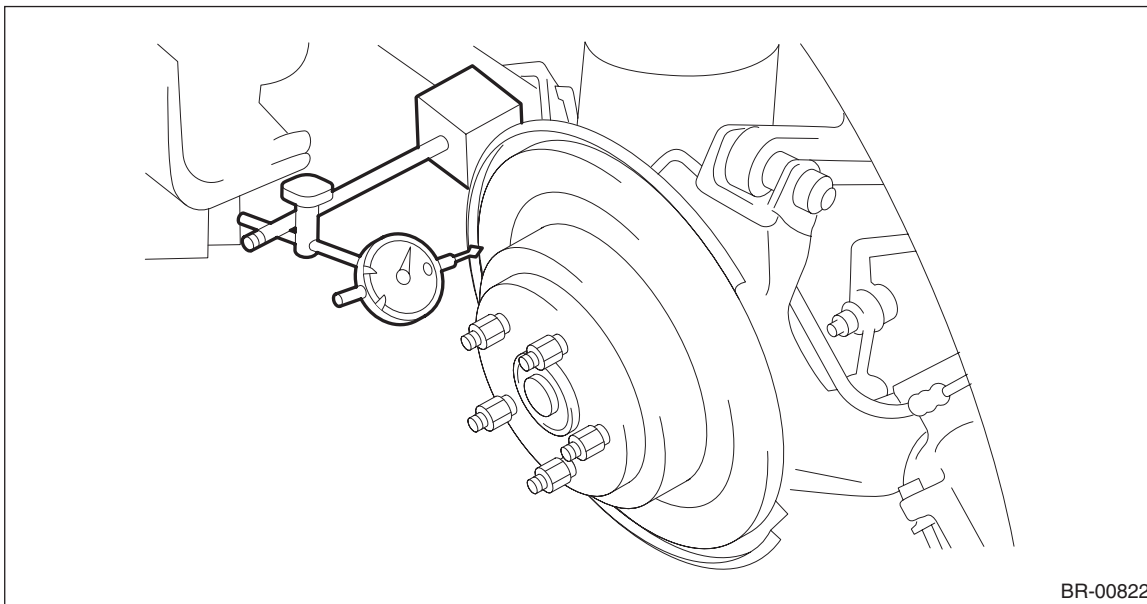

Service limit:

Maximum: 0.05 mm (0.0020 in)

8) After tightening the nut - axle, lock it securely.

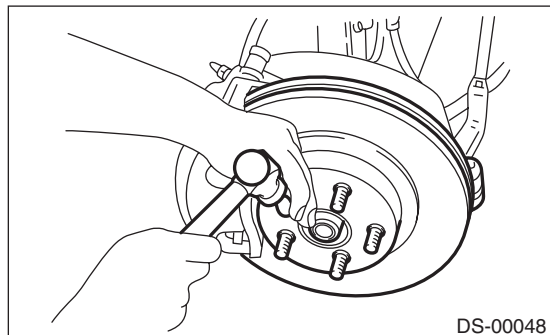

9) Install the rear wheels, and perform the following inspections.

Tightening torque:

120 N·m (12.24 kgf-m, 88.5 ft-lb)

1. Check the wheels for smooth rotation.
2. Check that there is no play by moving the upper and lower portions of rear tire in an axial direction with the brake pedal released.

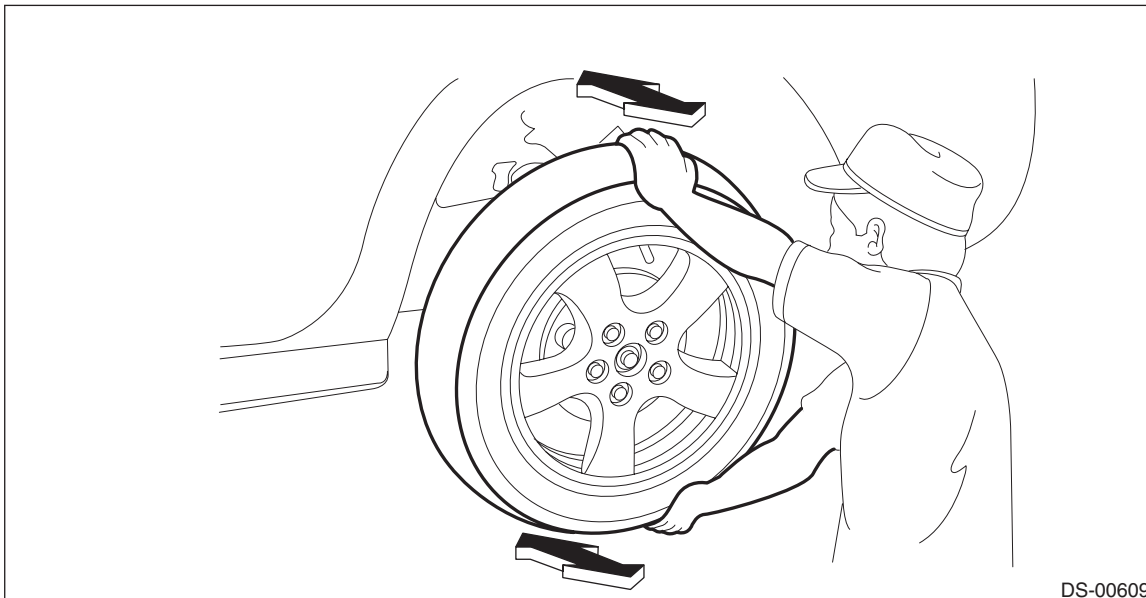

DS-00609

- **Play exists** → Check the hub unit COMPL - rear axle. <Ref. to DS-56, INSPECTION, Rear Hub Unit Bearing.>

Rear Hub Unit Bearing

DRIVE SHAFT SYSTEM

C: DISASSEMBLY

Using the ST or a hydraulic press, push out the bolt - hub (b) from the hub unit COMPL - rear axle (a).

CAUTION:

- Be careful not to hammer the bolts - hub. This may deform the hub unit COMPL.
- Do not reuse the bolt - hub.

PREPARATION TOOL:

ST: HUB STAND (28399AG000)

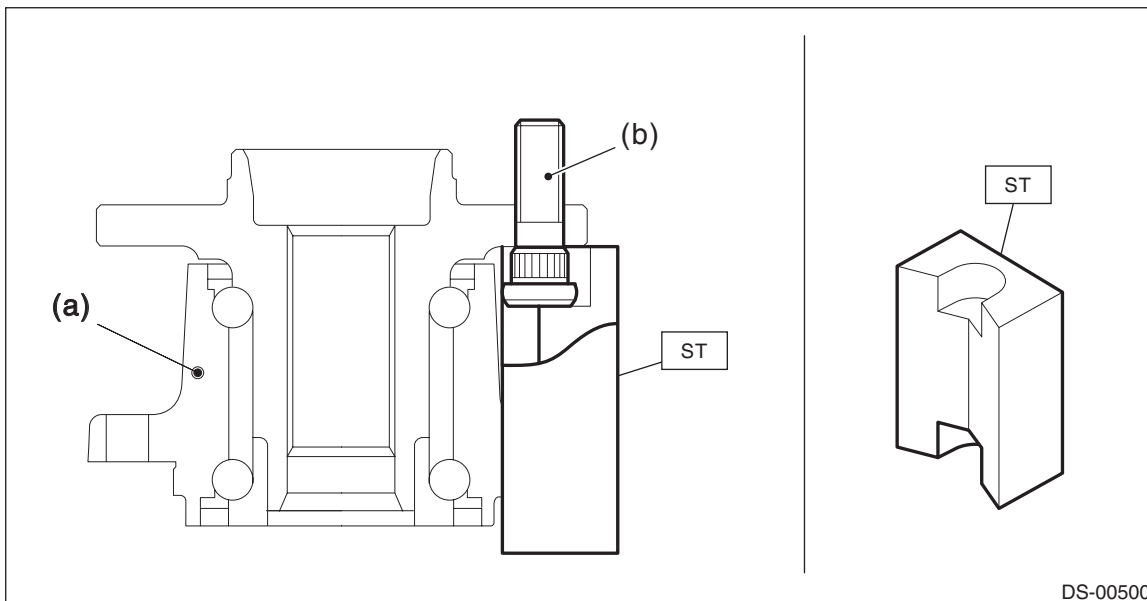

DS-00500

NOTE:

Since the hub unit COMPL - rear axle cannot be disassembled, only bolts - hub can be removed.

D: ASSEMBLY

1) Install the hub unit COMPL - rear axle to the ST securely.

Preparation tool:

ST: HUB STAND (927080000)

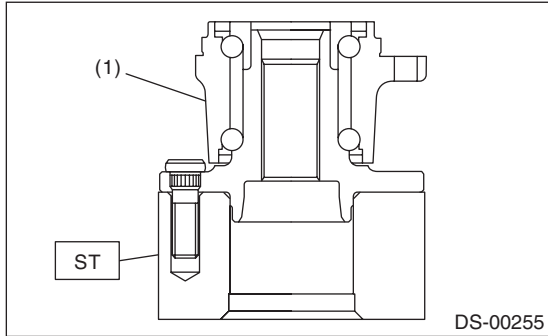

(1) Hub unit COMPL - rear axle

2) Using a press, press new bolts - hub (b) until their seating surfaces contact the hub unit COMPL - rear axle (a).

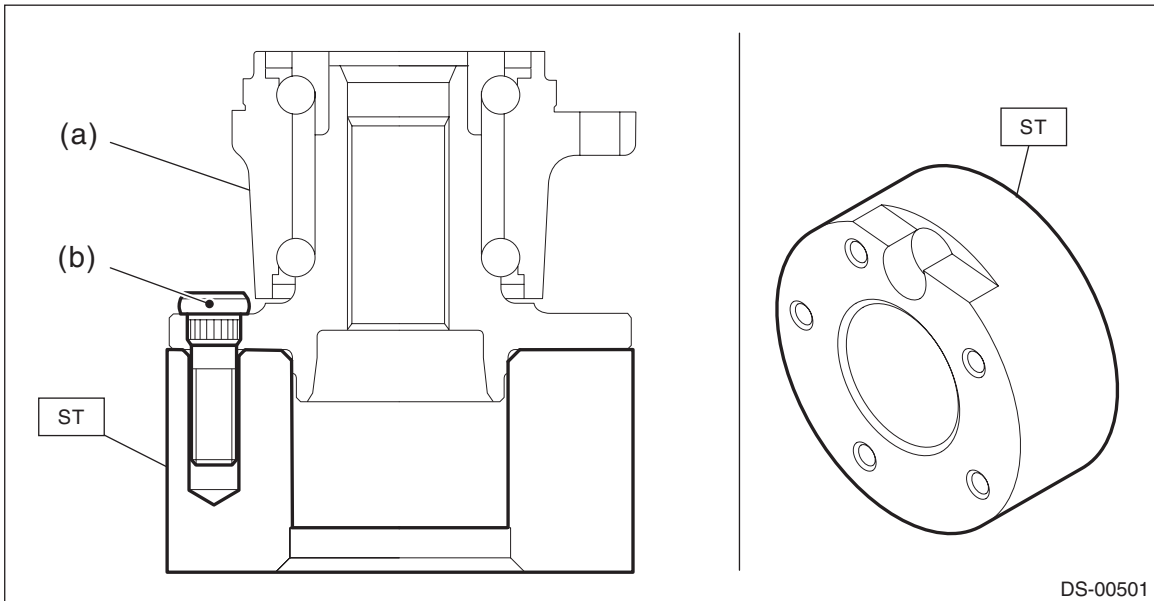

NOTE:

Use the 12 mm (0.47 in) dia. holes in the HUB STAND to prevent bolts from tilting.

Rear Hub Unit Bearing

DRIVE SHAFT SYSTEM

E: INSPECTION

1) Moving the rear tire up and down by hand, check there is no backlash in bearing, and check the wheel rotates smoothly.

CAUTION:

If there is any fault in the bearing, replace the hub unit COMPL - rear axle.

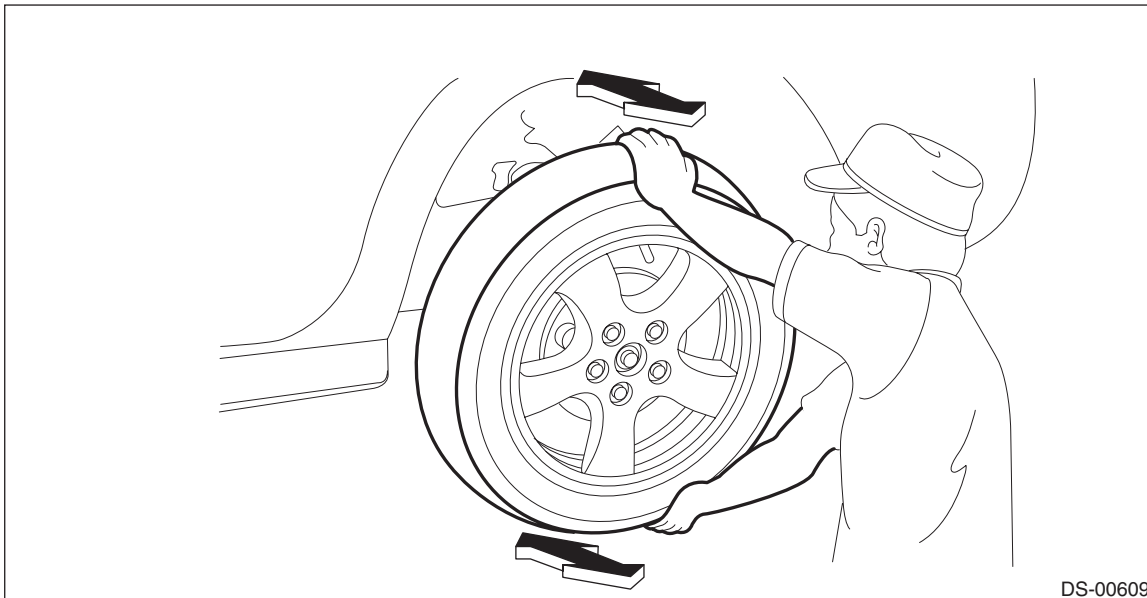

2) Inspect the lean of axis direction using a dial gauge. Replace the hub unit COMPL - rear axle if the play exceeds the limit.

Service limit:

Maximum: 0.05 mm (0.0020 in)

