

## 8. Rear Drive Shaft

### A: REMOVAL

- 1) Disconnect the ground cable from battery.
- 2) Lift up the vehicle, and then remove the rear wheels.
- 3) Remove the nut - axle.

#### CAUTION:

**Do not loosen the nut - axle while the rear axle is loaded. Doing so may damage the hub unit COMPL.**

- (1) Lift the crimped section of the nut - axle.
- (2) Remove the nut - axle using a socket wrench while depressing the brake pedal.

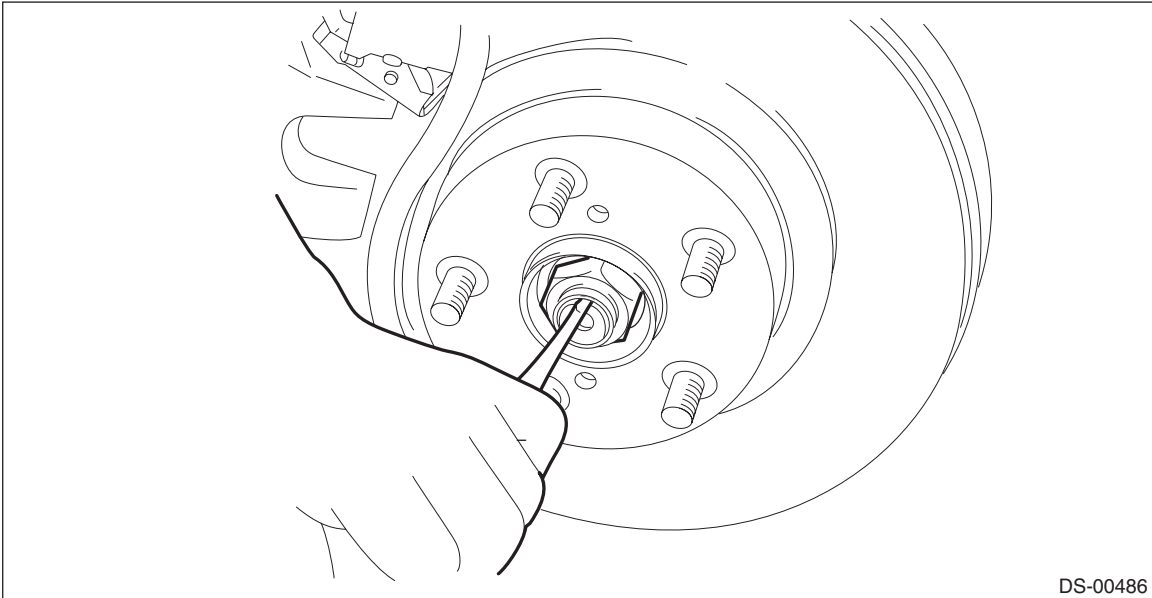

DS-00486

- 4) Remove the sensor assembly - headlight beam leveler. (Model with auto headlight beam leveler)
  - (1) Disconnect the connector of the sensor assembly - headlight beam leveler.
  - (2) Remove the bolts and nuts, and remove the sensor assembly - headlight beam leveler.

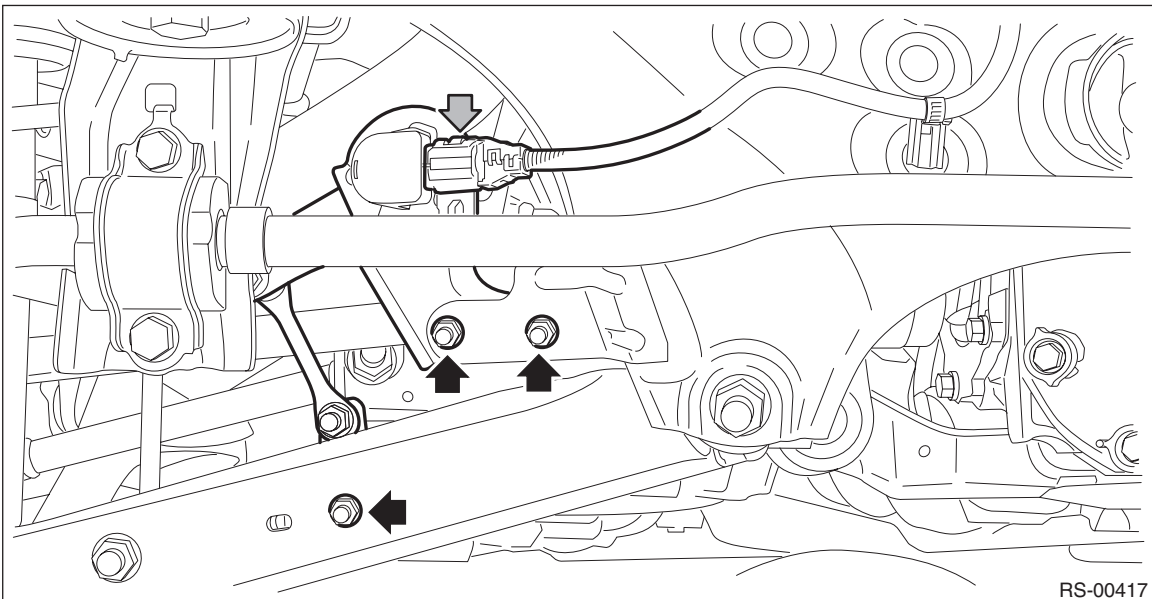

RS-00417

- 5) Drain differential gear oil.
- 6) Remove the propeller shaft. <Ref. to DS-12, REMOVAL, Propeller Shaft.>

# Rear Drive Shaft

## DRIVE SHAFT SYSTEM

7) Loosen the joint of rear differential assembly and rear axle shaft assembly.

- T type: Pull out the rear axle shaft assembly by fitting the ST to the bolt (a) as shown in the figure.

### CAUTION:

Fit the ST to the bolts as shown in the figure to prevent damage of the side bearing retainer.

**Preparation tool:**

**ST: DRIVE SHAFT REMOVER (28099PA100)**

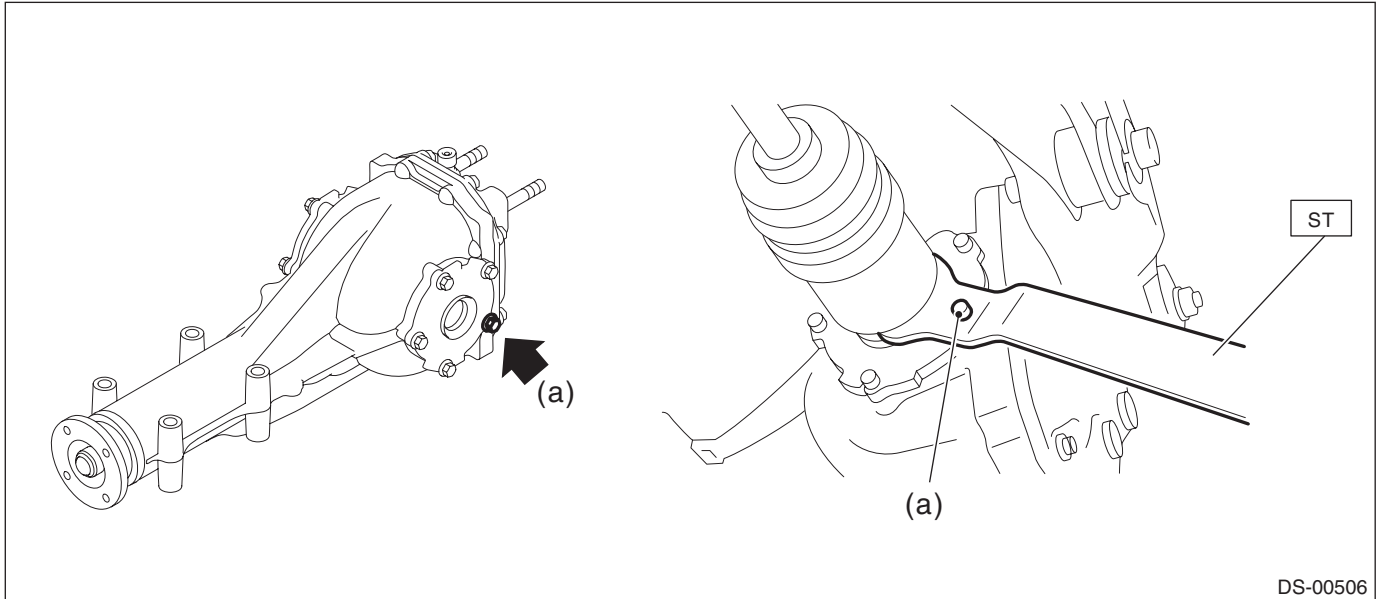

- VA type: Pull out the rear axle shaft assembly by fitting the tire lever (b) to the bolt (a) as shown in the figure.

### CAUTION:

To prevent damage to the side bearing retainer, use by placing the tire lever against the bolt as shown in the figure.

**Preparation tool:**

**Tire lever**

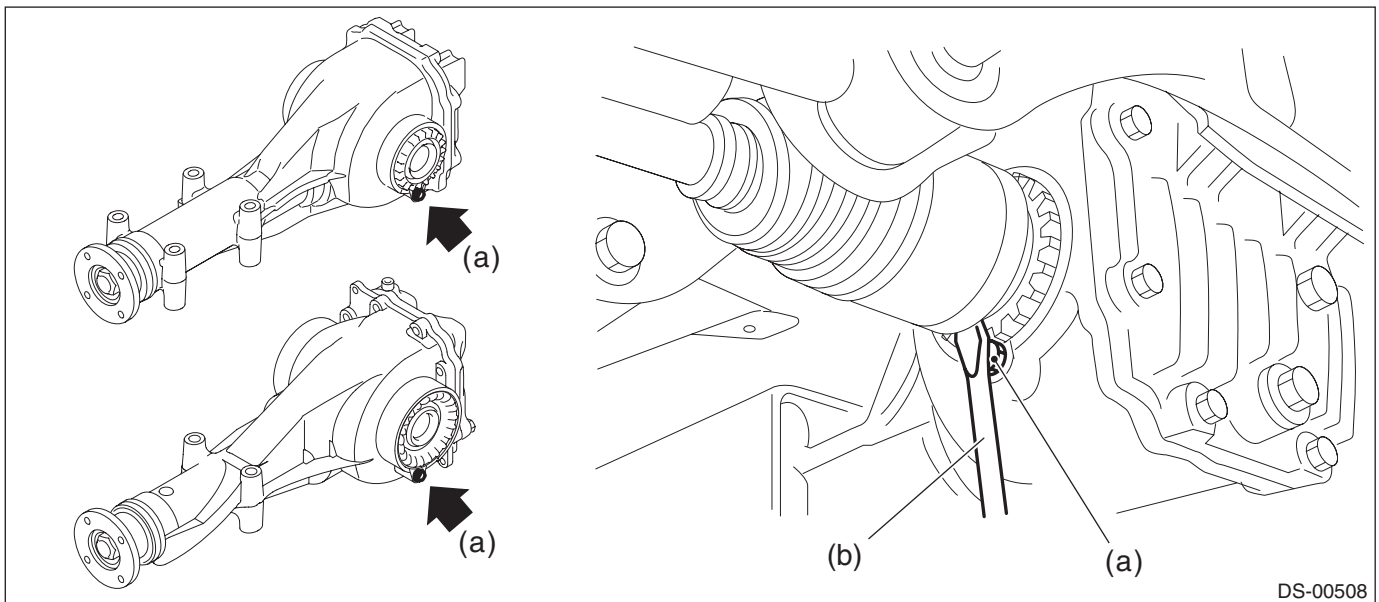

- 8) Remove the installation section of rear differential assembly.
- (1) Support the rear differential assembly with a transmission jack.
  - (2) Remove the bolts which hold the rear differential front crossmember from the rear sub frame assembly.

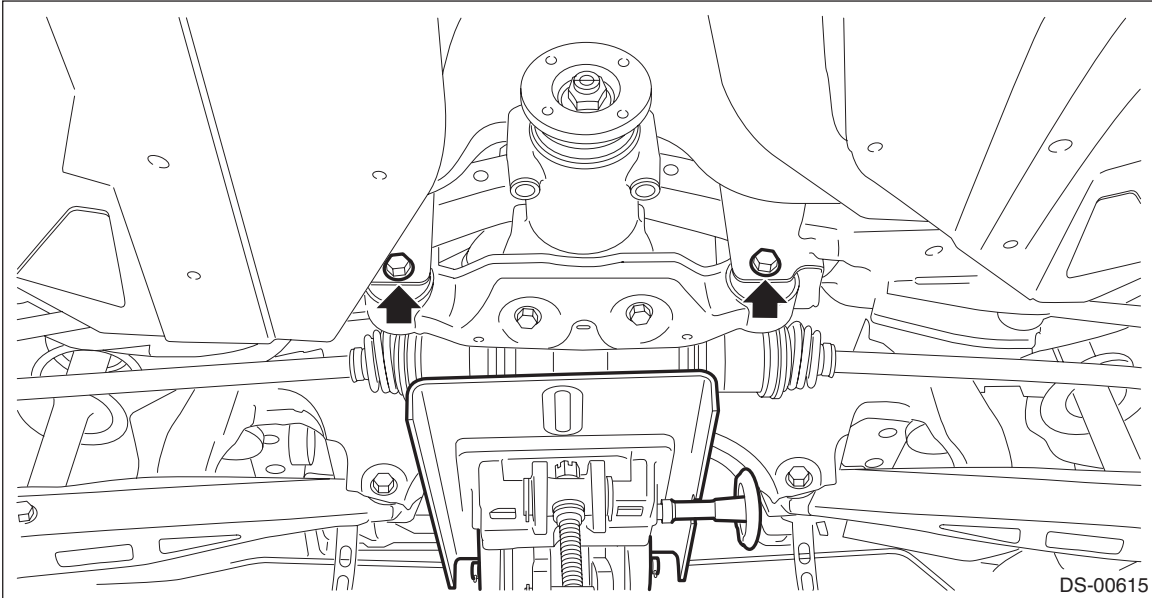

- (3) Remove the self-locking nuts which hold the rear differential to the rear sub frame assembly.

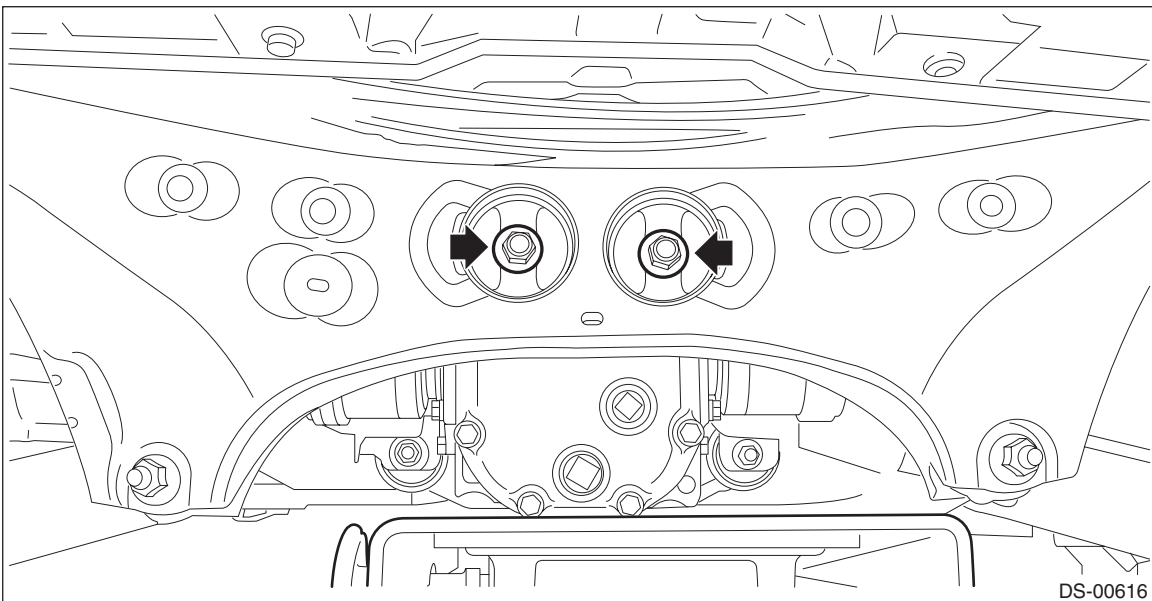

## Rear Drive Shaft

### DRIVE SHAFT SYSTEM

---

9) Completely pull out the rear axle shaft assembly while lowering the rear differential.

**CAUTION:**

**Pay attention to avoid damaging the boot of axle shaft.**

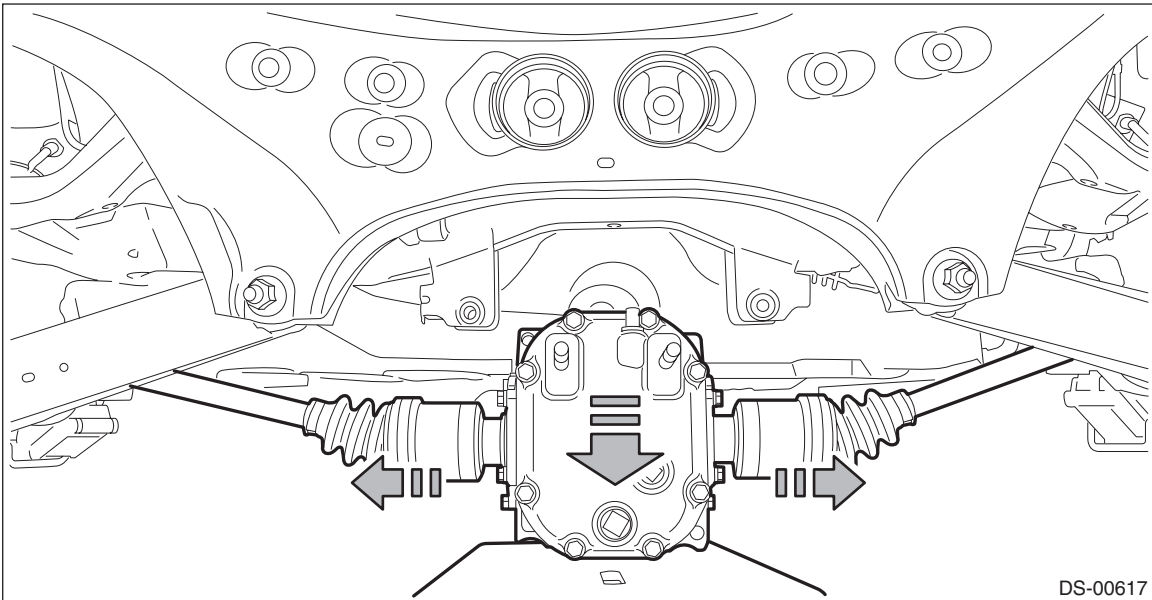

10) Remove the rear axle shaft assembly from the housing assembly - rear axle.

**NOTE:**

If it is hard to remove, use the ST.

**Preparation tool:**

**ST1: AXLE SHAFT PULLER (926470000)**

**ST2: AXLE SHAFT PULLER PLATE (28099PA110)**

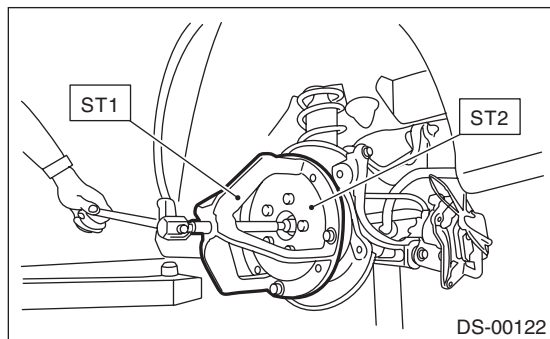

**B: INSTALLATION**

1) Replace the rear differential side oil seal. <Ref. to DI-58, REPLACEMENT, Rear Differential Side Oil Seal.>

**NOTE:**

After pulling out the axle shaft assembly, be sure to replace with a new oil seal.

2) Insert the axle shaft assembly into the rear hub spline, and pull in the axle shaft assembly into specified position.

**CAUTION:**

- Be careful not to damage the magnetic encoder.
- Do not get closer the tool which charged magnetism to magnetic encoder.
- Do not tap the axle shaft using a hammer when installing axle shaft assembly.

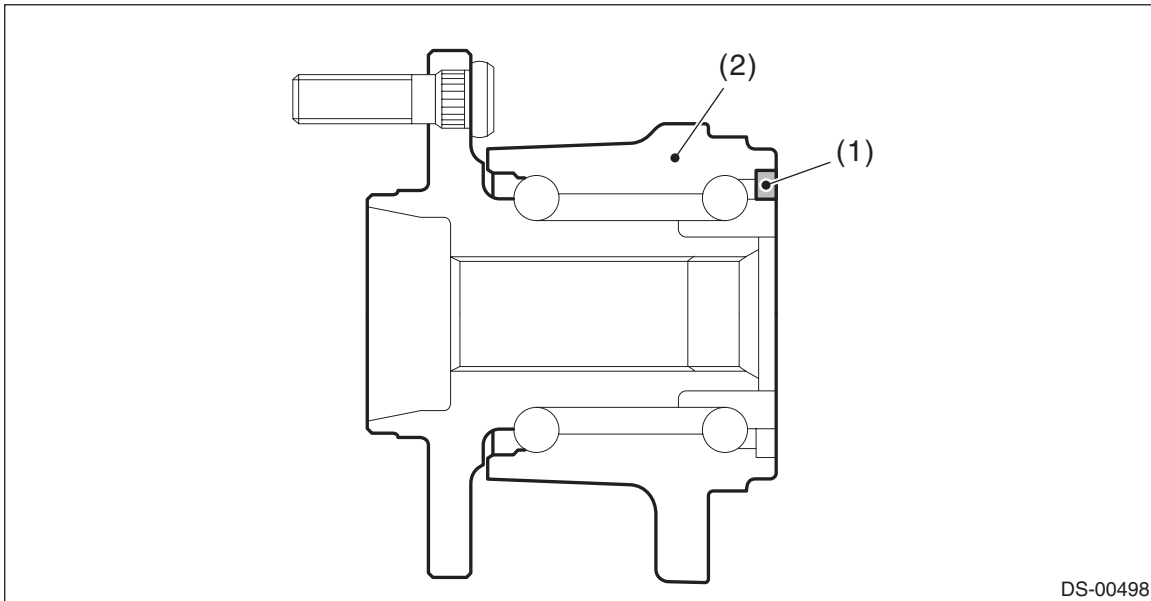

DS-00498

(1) Magnetic encoder

(2) Hub unit COMPL - rear axle

3) Temporarily tighten the nut - axle.

4) Using the ST, install the rear axle shaft assembly to the rear differential.

**Preparation tool:**

**ST: OIL SEAL PROTECTOR (28099PA090)**

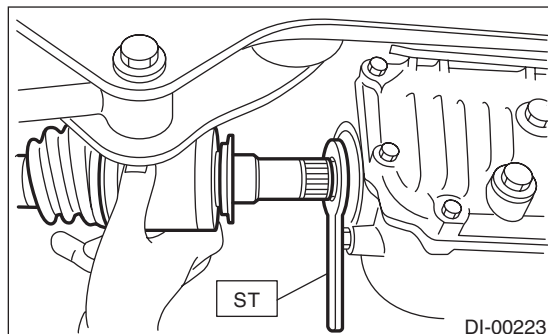

5) Install the rear differential assembly to the rear sub frame assembly.

**CAUTION:**

Be sure to use a new self-locking nut.

**Tightening torque:**

**Differential assembly — bushing - differential: 70 N·m (7.14 kgf-m, 51.6 ft-lb)**

**Differential assembly — rear sub frame assembly: 110 N·m (11.22 kgf-m, 81.1 ft-lb)**

## Rear Drive Shaft

### DRIVE SHAFT SYSTEM

---

6) Install the sensor assembly - headlight beam leveler.

**Tightening torque:**

**7.5 N·m (0.76 kgf-m, 5.5 ft-lb)**

7) While pressing the brake pedal, tighten the new axle nuts to the specified torque.

**CAUTION:**

**Do not load the rear axle before tightening the nut - axle. Doing so may damage the hub unit COMPL.**

**Tightening torque:**

**190 N·m (19.37 kgf-m, 140.1 ft-lb)**

8) Lock the nut - axle securely.

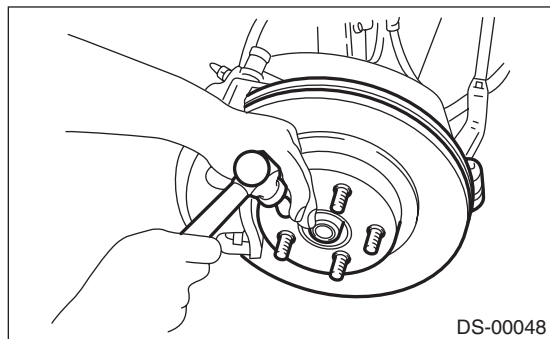

9) Fill differential gear oil.

10) Install the rear wheels.

**Tightening torque:**

**120 N·m (12.24 kgf-m, 88.5 ft-lb)**

11) Perform reinitialization of the auto headlight beam leveler system. (Model with auto headlight beam leveler) <Ref. to LI-17, PROCEDURE, Auto Headlight Beam Leveler System.>

## C: DISASSEMBLY

1) Take out the DOJ outer race from the shaft assembly.

**CAUTION:**

**Be careful not to damage the boot.**

(1) Using a flat tip screwdriver or plier, loosen the boot band on the large end of DOJ boot.

**CAUTION:**

**Be careful not to damage the boot.**

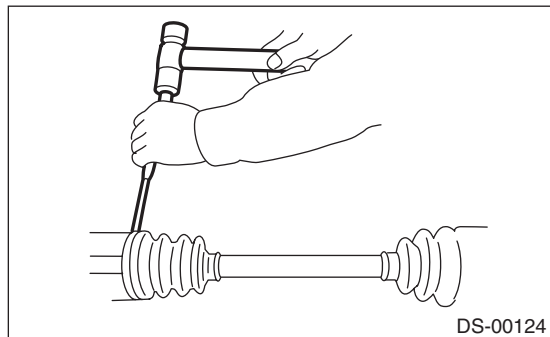

(2) Remove the boot band on the small end of DOJ boot in the same manner.

(3) Remove the large end of DOJ boot from DOJ outer race.

- (4) Remove the round snap ring at the neck of DOJ outer race with a flat tip screwdriver.

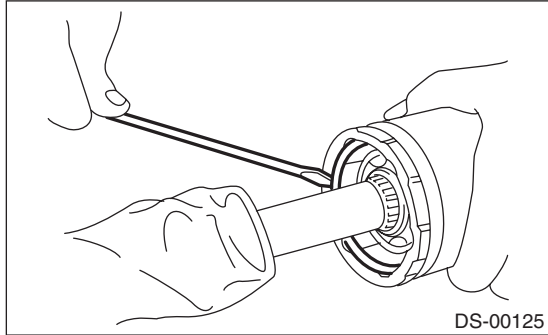

- (5) Take out the DOJ outer race from the shaft assembly.  
 (6) Wipe off the grease and take out the ball bearings.

**CAUTION:**

The grease is a special grease (grease for constant velocity joints). Do not mix with other greases.

**NOTE:**

Disassemble the parts taking care not to lose balls.

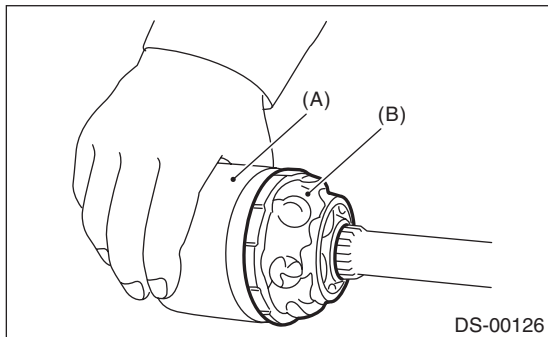

- (A) Outer race  
 (B) Grease

- 2) Remove the cage from the inner race.  
 (1) Turn the cage by a half pitch to the track groove of inner race and shift the cage.  
 (2) Using pliers, remove the snap ring fixing the inner race to the shaft.

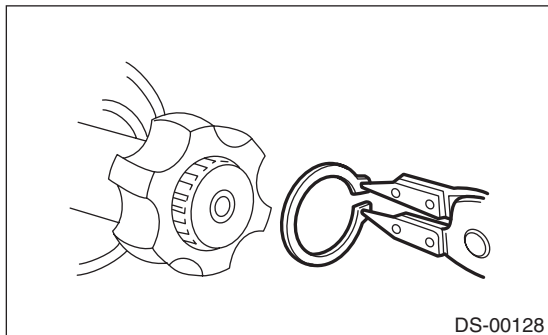

- (3) Take out the DOJ inner race.  
 (4) Take off the DOJ cage from shaft and remove the DOJ boot.

**CAUTION:**

Wrap shaft splines with vinyl tape to protect the boot from scratches.

- 3) Remove the BJ boot or EBJ boot in the same procedure as the DOJ boot.

**NOTE:**

The BJ is a non-disassembly part, so the axle shaft disassembly stops here.

# Rear Drive Shaft

## DRIVE SHAFT SYSTEM

---

### D: ASSEMBLY

#### 1. MT MODEL

##### CAUTION:

Wrap shaft splines with vinyl tape to protect the boot from scratches.

##### NOTE:

Use specified grease.

##### Grease:

**BJ, EBJ side: NKG814**

**DOJ side: NKG814**

1) Install the DOJ inner race to the shaft.

(1) Install the EBJ boot to the specified position, and fill it with 50 to 60 g (1.76 to 2.12 oz) of specified grease.

(2) Place the DOJ boot at the center of shaft.

(3) Insert the DOJ cage onto shaft.

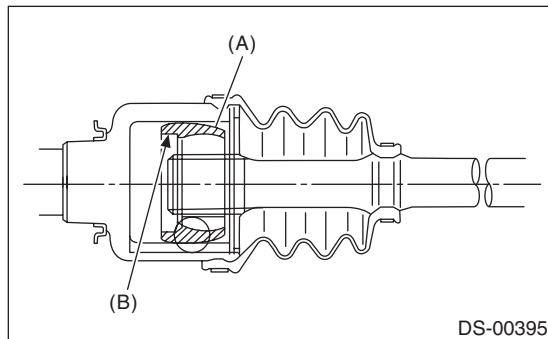

(A) Cage

(B) Cutout portion

##### NOTE:

Insert the cage with the cutout portion facing the shaft end, since the cage has an orientation.

(4) Install the DOJ inner race on shaft and fix the snap ring in place with pliers.

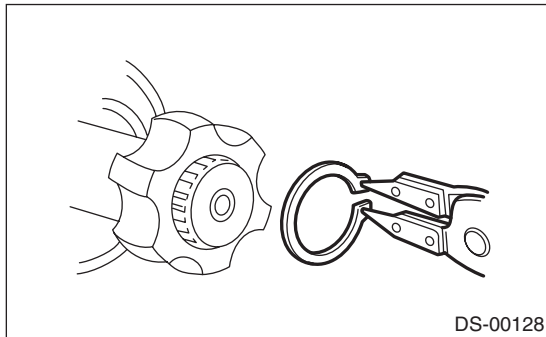

##### NOTE:

Confirm that the snap ring is completely fitted in the shaft groove.



2) Install the cage to the inner race.

- (1) Install the cage (B) with the protruding section aligned with the track on the inner race (A), and turn by a half pitch.

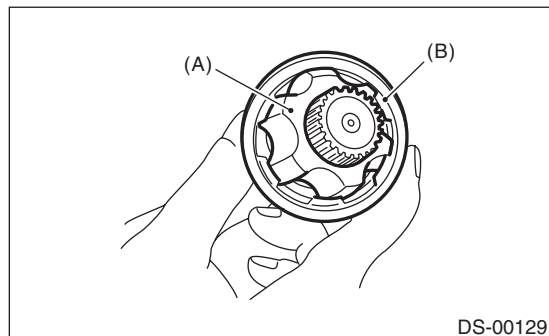

- (2) Fill 80 to 90 g (2.82 to 3.17 oz) of specified grease into the inner side of the DOJ outer race.  
 (3) Apply a thin coat of specified grease to the cage pocket and ball.  
 (4) Insert the ball bearings into the cage pocket.

3) Connect the shaft assembly to the outer race.

- (1) Align the outer race track and ball positions, and place the shaft, inner race, cage and ball bearings in the original positions, and then fix outer race in place.

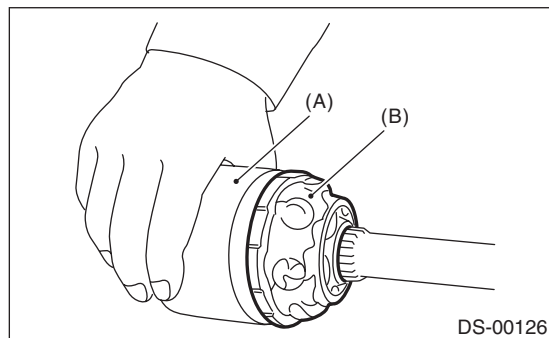

- (A) Outer race  
 (B) Grease

- (2) Install the snap ring in the groove on the DOJ outer race.

**CAUTION:**

**Be careful of the following items during installation:**

- **Make sure that the balls, cage and inner race are completely fitted in the outer race of DOJ.**
- **Use care not to place the matched position of snap ring in the ball groove of outer race.**
- **Pull the shaft lightly and assure that the circlip is completely fitted in the groove.**

- (3) Apply an even coat of the specified grease [20 to 30 g (0.71 to 1.06 oz)] to the entire inner surface of boot. Also apply grease to the shaft.  
 (4) Install the DOJ boot taking care not to twist it.

**NOTE:**

- The inside of the large end of DOJ boot and the boot groove shall be cleaned so as to be free from grease and other substances.
- When installing the DOJ boot, position the outer race of DOJ at center of the stroke.  
 (5) Put a new band through the clip and wind twice in the band groove of the boot.  
 (6) Pinch the end of band with pliers. Hold the clip and tighten securely.

**NOTE:**

When tightening boot, use care so that the air within the boot is appropriate.

## Rear Drive Shaft

### DRIVE SHAFT SYSTEM

---

(7) Tighten the band using the ST.

**Preparation tool:**

**ST: BAND TIGHTENING TOOL (925091000)**

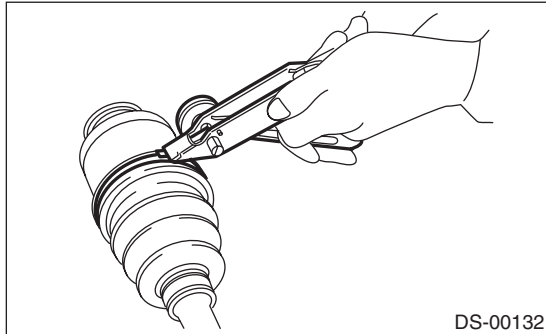

**NOTE:**

Tighten the band until it cannot be moved by hand.

(8) Tap the clip with the punch provided at the end of the ST.

**Preparation tool:**

**ST: BAND TIGHTENING TOOL (925091000)**

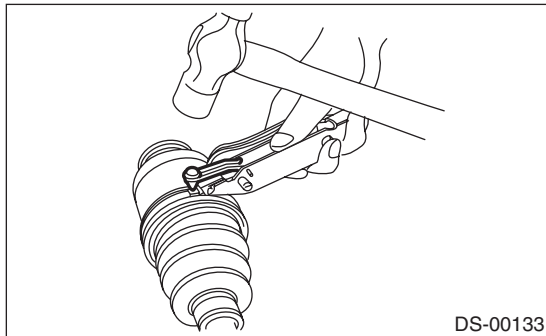

**NOTE:**

Tap to an extent that the boot underneath is not damaged.

(9) Cut off the band with an allowance of about 10 mm (0.39 in) left from the clip and bend this allowance over the clip.

**CAUTION:**

**Make sure that the end of the band is in close contact with clip.**

4) Extend and retract the DOJ repeatedly to provide an equal coating of grease.

## 2. CVT MODEL

### CAUTION:

Wrap shaft splines with vinyl tape to protect the boot from scratches.

### NOTE:

Use specified grease.

### Grease:

**BJ side: Raremax LF-G**

**DOJ side: Raremax LF-G**

1) Install the DOJ inner race to the shaft.

(1) Install the BJ boot to the specified position, and fill it with 50 to 60 g (1.76 to 2.12 oz) of specified grease.

(2) Place the DOJ boot at the center of shaft.

(3) Insert the DOJ cage onto shaft.

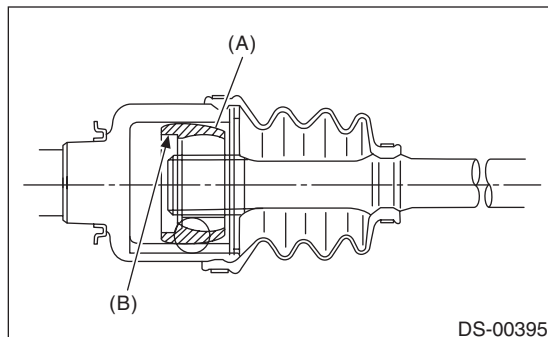

(A) Cage

(B) Cutout portion

### NOTE:

Insert the cage with the cutout portion facing the shaft end, since the cage has an orientation.

(4) Install the DOJ inner race on shaft and fix the snap ring in place with pliers.

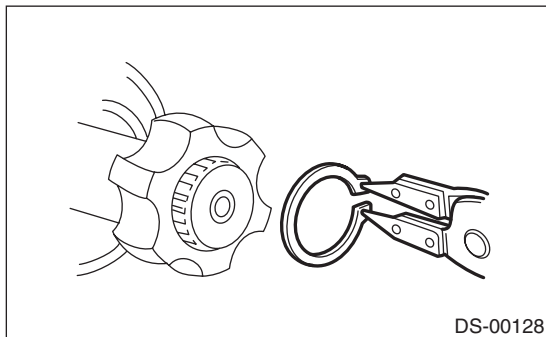

### NOTE:

Confirm that the snap ring is completely fitted in the shaft groove.

## Rear Drive Shaft

### DRIVE SHAFT SYSTEM

---

#### 2) Install the cage to the inner race.

- (1) Install the cage (B) with the protruding section aligned with the track on the inner race (A), and turn by a half pitch.

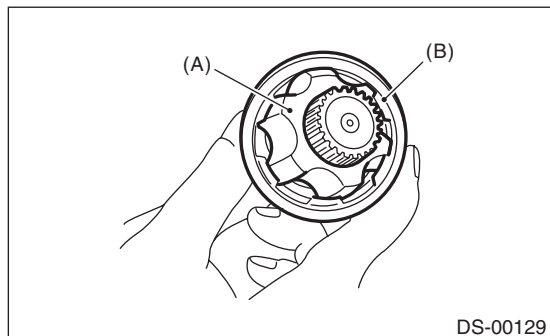

- (2) Fill 80 to 90 g (2.82 to 3.17 oz) of specified grease into the inner side of the DOJ outer race.

- (3) Apply a thin coat of specified grease to the cage pocket and ball.

- (4) Insert the ball bearings into the cage pocket.

#### 3) Connect the shaft assembly to the outer race.

- (1) Align the outer race track and ball positions, and place the shaft, inner race, cage and ball bearings in the original positions, and then fix outer race in place.

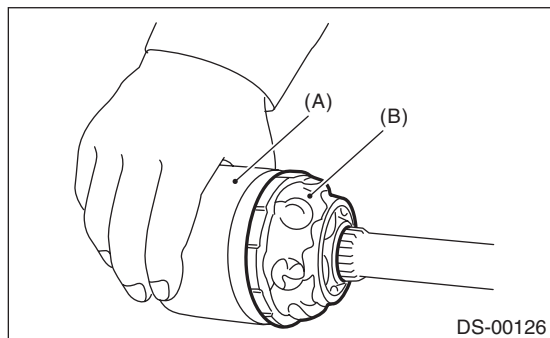

(A) Outer race

(B) Grease

- (2) Install the snap ring in the groove on the DOJ outer race.

#### **CAUTION:**

##### **Be careful of the following items during installation:**

- **Make sure that the balls, cage and inner race are completely fitted in the outer race of DOJ.**
- **Use care not to place the matched position of snap ring in the ball groove of outer race.**
- **Pull the shaft lightly and assure that the circlip is completely fitted in the groove.**

- (3) Apply an even coat of the specified grease [20 to 30 g (0.71 to 1.06 oz)] to the entire inner surface of boot. Also apply grease to the shaft.

- (4) Install the DOJ boot and BJ boot taking care not to twist it.

#### **NOTE:**

- The inside of the large end of DOJ boot and the boot groove shall be cleaned so as to be free from grease and other substances.
- When installing the DOJ boot, position the outer race of DOJ at center of the stroke.

(5) Prepare a new band, pinch (a) and (e) of the band with needle nose pliers, and align it with the groove of the boot.

**CAUTION:**

- Be careful not to damage the boot.
- When tightening boot, use care so that the air within the boot is appropriate.

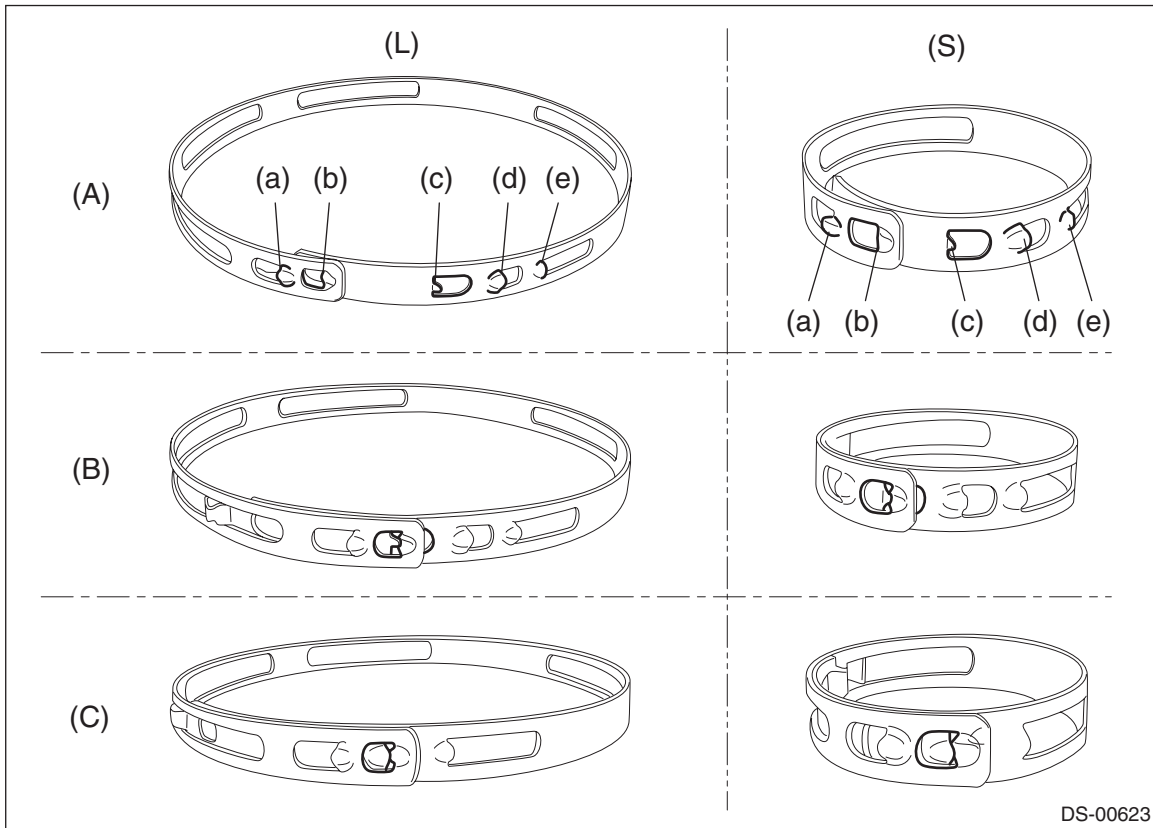

- |                                  |   |                                  |
|----------------------------------|---|----------------------------------|
| (L) Band for large diameter      | (S) Band for small diameter                         |                                  |
| (A) Free position                | (B) Temporarily tightening position                 | (C) Fully tightening position    |
| (a) Holding portion using pliers | (c) Convex claw for temporarily tightening position | (e) Holding portion using pliers |
| (b) Concave claw                 | (d) Convex claw                                     |                                  |

# Rear Drive Shaft

## DRIVE SHAFT SYSTEM

(6) Pinch (a) and (e) of the band with needle nose pliers, and align the concave claw (b) with the convex claw (c) for temporarily tightening position.

**Preparation tool:**  
**Needle nose pliers**

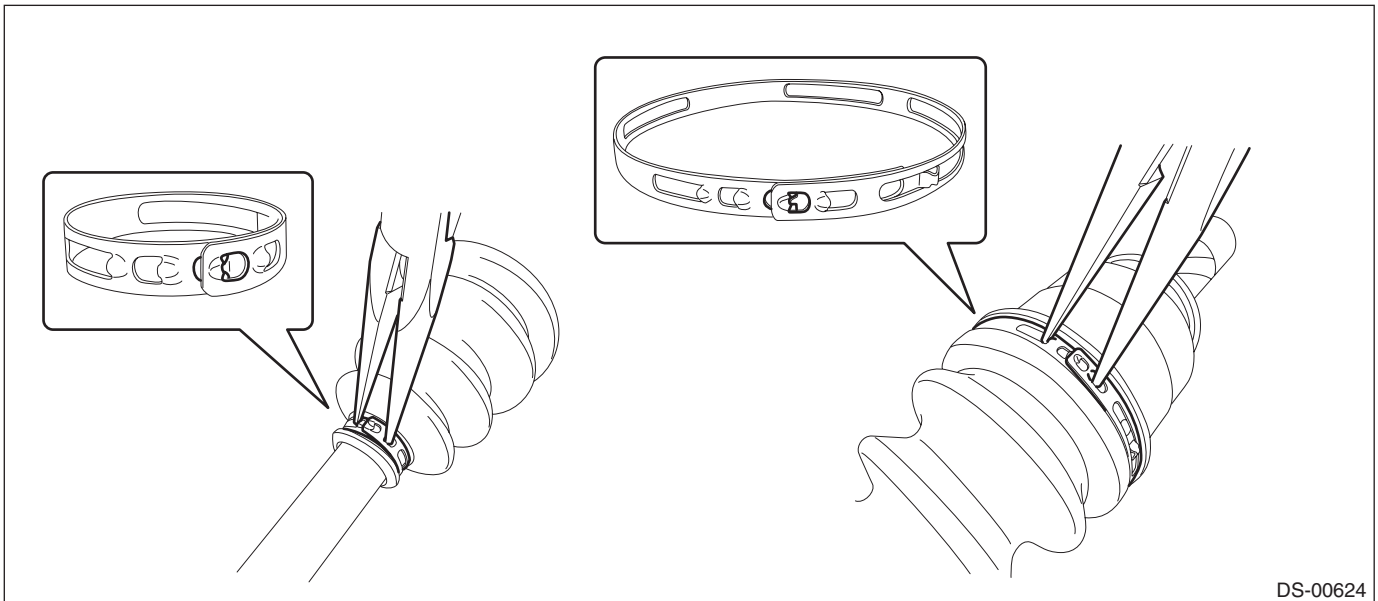

(7) Check the positions of the boot and band, align the concave claw (b) with the convex claw (d), and tighten the band.

4) Extend and retract the DOJ repeatedly to provide an equal coating of grease.

## E: INSPECTION

Check the removed parts for damage, wear, corrosion etc. Repair or replace if defective.

- **DOJ (Double Offset Joint):**

Check for seizure, corrosion, damage, wear and excessive play.

- **BJ (Bell Joint):**

Check for seizure, corrosion, damage and excessive play.

- **EBJ (High-Efficiency Compact Ball fixed Joint)**

Check for seizure, corrosion, damage and excessive play.

- **Shaft:**

Check for excessive bending, twisting, damage and wear.

- **Boot:**

Check for wear, warping, breakage and scratches.

- **Grease:**

Check for discoloration and fluidity.