

4. VDC Control Module and Hydraulic Control Unit (VDCCM&H/U)

A: REMOVAL

- 1) Disconnect the ground cable from battery.
- 2) Remove the intake boot. <Ref. to IN(H4DO)-12, REMOVAL, Air Intake Boot.>

CAUTION:

Move aside the intake boot to perform the operation without disconnecting the PCV hose.

- 3) Remove the VDC control module & hydraulic control unit (VDCCM&H/U).
 - (1) Remove any dirt from around the VDCCM&H/U.
 - (2) Pull up the lock lever (b) while pressing the lock button (a) and disconnect the VDCCM&H/U connector.

CAUTION:

Do not pull on the harness when disconnecting the connector.

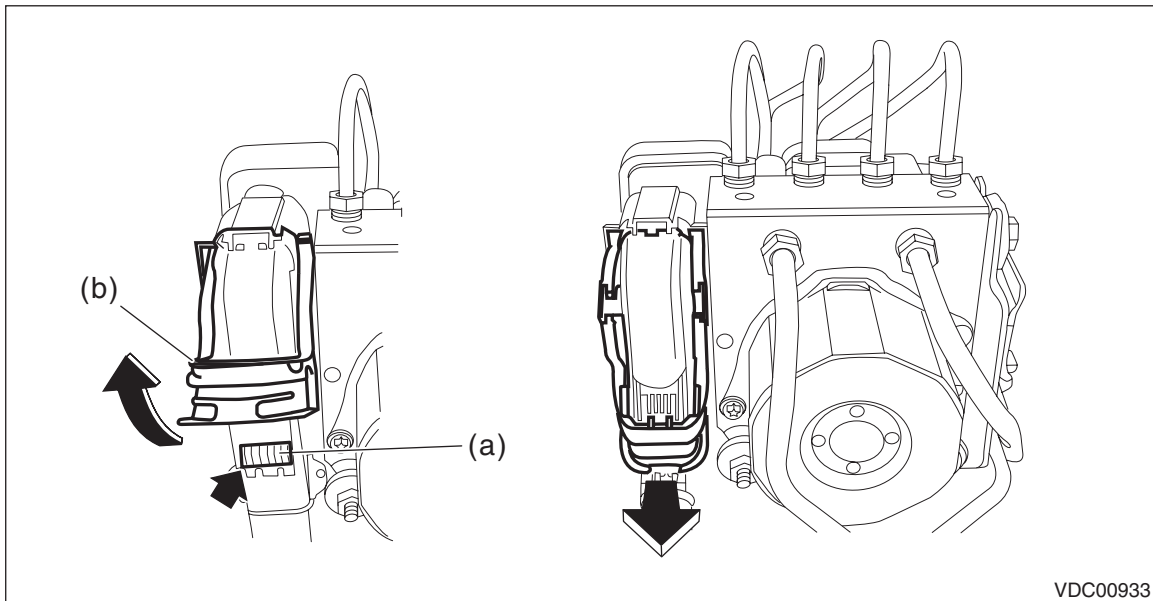

VDC00933

VDC Control Module and Hydraulic Control Unit (VDCCM&H/U)

VEHICLE DYNAMICS CONTROL (VDC)

(3) Using a flare nut wrench, disconnect each brake pipe from VDCCM&H/U.

CAUTION:

- Wrap the brake pipe with a vinyl bag so as not to spill the brake fluid on the painted surface of the vehicle body.
- If brake fluid is spilled on the painted surface of the vehicle body, wash it off immediately with water and wipe clean.

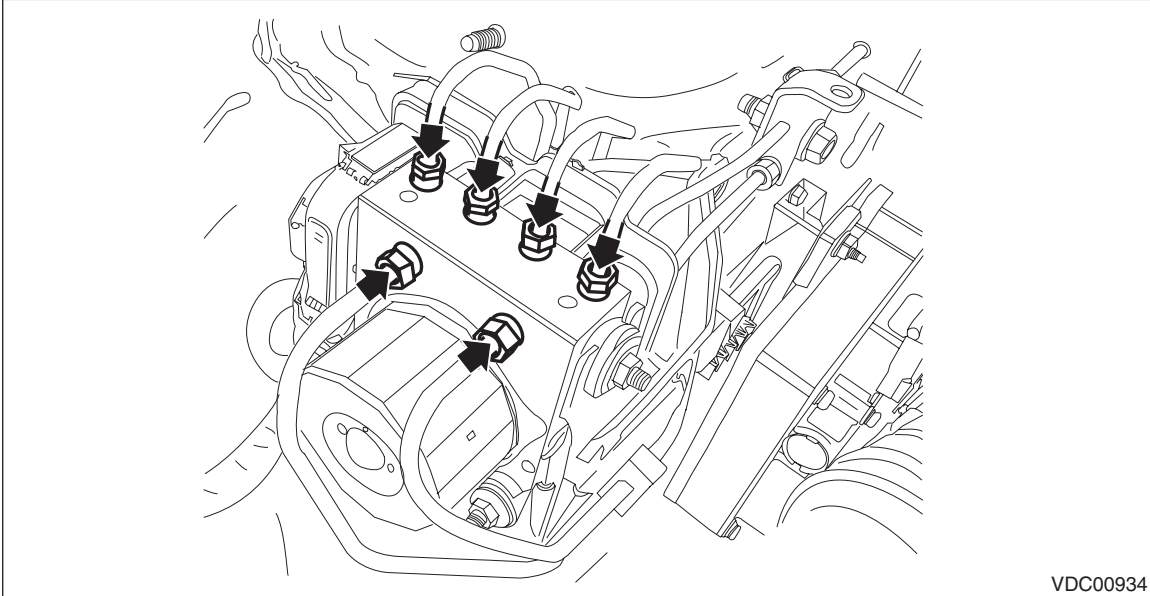

VDC00934

(4) Remove the nuts and remove the VDCCM&H/U from the bracket - hydraulic unit.

CAUTION:

- Do not drop or bump the VDCCM&H/U.
- Do not turn the VDCCM&H/U upside down or place it sideways for storage.
- Be careful not to let foreign matter enter the VDCCM&H/U.
- Be careful that no water and fluid enter the connectors.

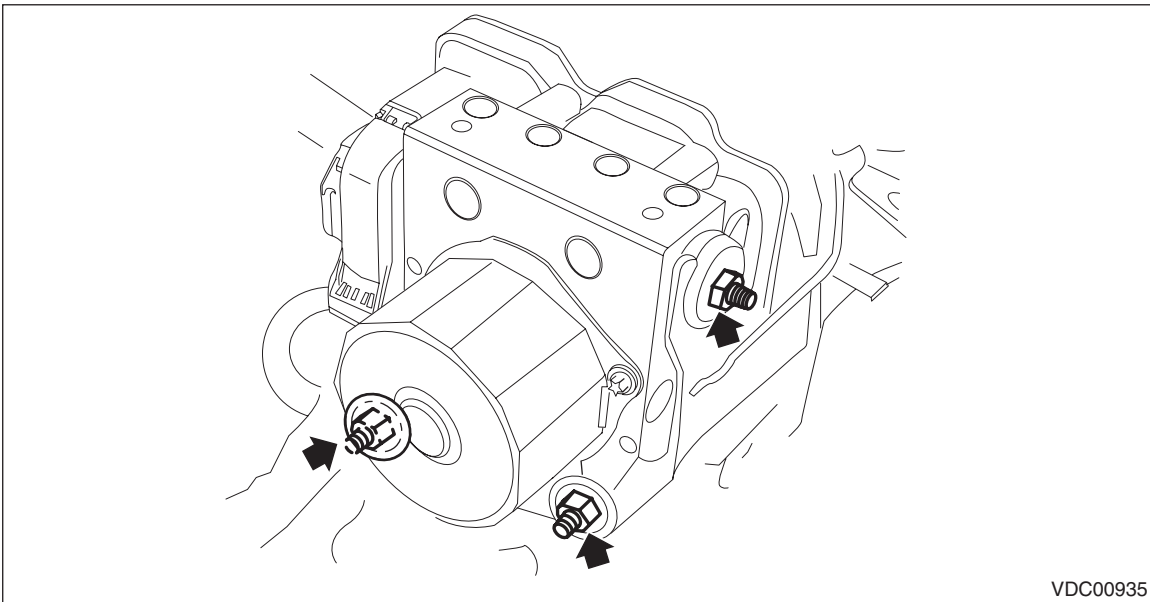

VDC00935

B: INSTALLATION

CAUTION:

- When installing the VDCCM&H/U to the bracket - hydraulic unit, make sure that there is no oil adhered to the bolts and the threads of VDCCM&H/U. If the oil is adhered, degrease it carefully before tightening.
 - Connect the VDCCM&H/U connector securely.
 - When installing the VDCCM&H/U, replace the damper - hydraulic unit, spacer and nut with new parts.
- 1) Install each part in the reverse order of removal.

Tightening torque:

Refer to “COMPONENT” of “General Description”. <Ref. to VDC-5, VDC CONTROL MODULE & HYDRAULIC CONTROL UNIT (VDCCM&H/U), COMPONENT, General Description.>

- 2) Bleed air from the brake system. <Ref. to BR-59, Air Bleeding.>
3) Perform parameter confirmation, selection, and registration.

NOTE:

- When the VDCCM&H/U is replaced with a new part, be sure to perform the selection · registration operation.
 - Be sure to use the Subaru Select Monitor for the selection and registration of parameter.
 - When the registration has not been performed, the DTC code “Parameter selection error” is detected together with the ABS/EBD/VDC warning light illumination.
 - (1) Check that the applied model and grade of the relevant vehicle are included. <Ref. to VDC(diag)-19, PARAMETER CHECK, OPERATION, Subaru Select Monitor.>
 - (2) On {Confirm on parameter} display, enter the applied model of the relevant vehicle and check if it is correct. If the information is not correct, perform parameter selection and registration. <Ref. to VDC(diag)-19, PARAMETER SELECTION, OPERATION, Subaru Select Monitor.>
- 4) Perform mode setting for each sensor.
- VDC sensor midpoint setting mode: <Ref. to VDC-19, VDC SENSOR MIDPOINT SETTING MODE, ADJUSTMENT, VDC Control Module and Hydraulic Control Unit (VDCCM&H/U).>

C: INSPECTION

- 1) Check the identification (a) of the VDC control module & hydraulic control unit (VDCCM&H/U).

NOTE:

For the identification, refer to “SPECIFICATION” in “General Description”. <Ref. to VDC-2, SPECIFICATION, General Description.>

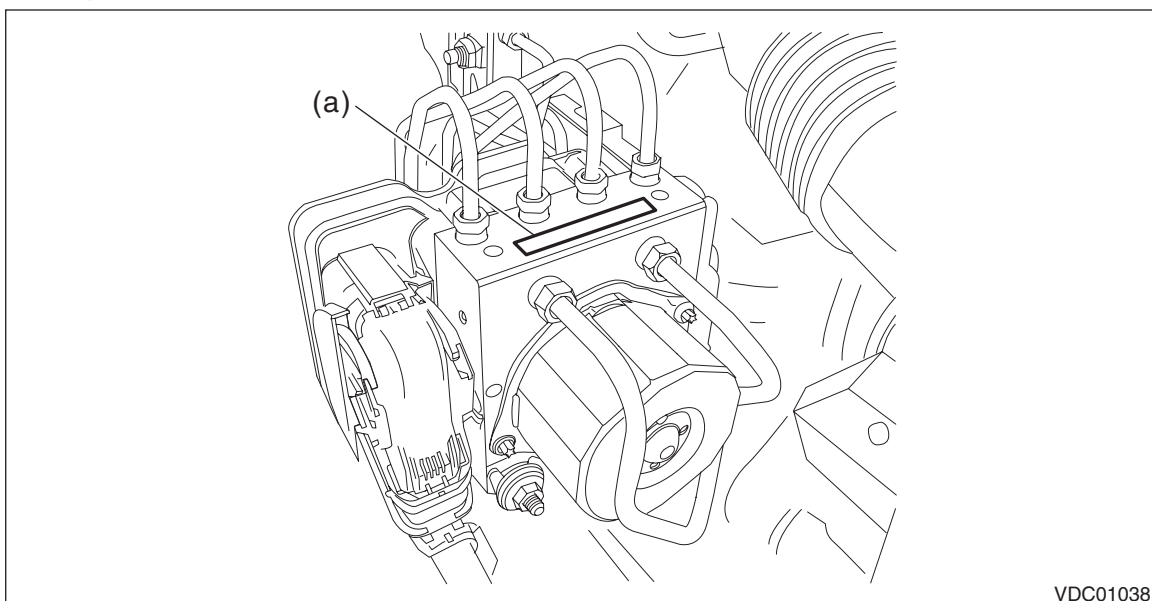

- 2) Check the condition of connection and settlement of connector, and correct or replace if defective.

VDC Control Module and Hydraulic Control Unit (VDCCM&H/U)

VEHICLE DYNAMICS CONTROL (VDC)

1. CHECKING THE HYDRAULIC UNIT ABS OPERATION BY PRESSURE GAUGE

- 1) Lift up the vehicle, and then remove the wheel.
- 2) Remove the bleeder - screws from the FL and FR caliper bodies.
- 3) Connect two pressure gauges to FL and FR caliper bodies.

CAUTION:

- Use a pressure gauge used exclusively for brake fluid measurement.
- Do not use the pressure gauge used for the measurement of transmission oil. Doing so will cause the piston seal to expand and deform.

NOTE:

Wrap sealing tape around the pressure gauge.

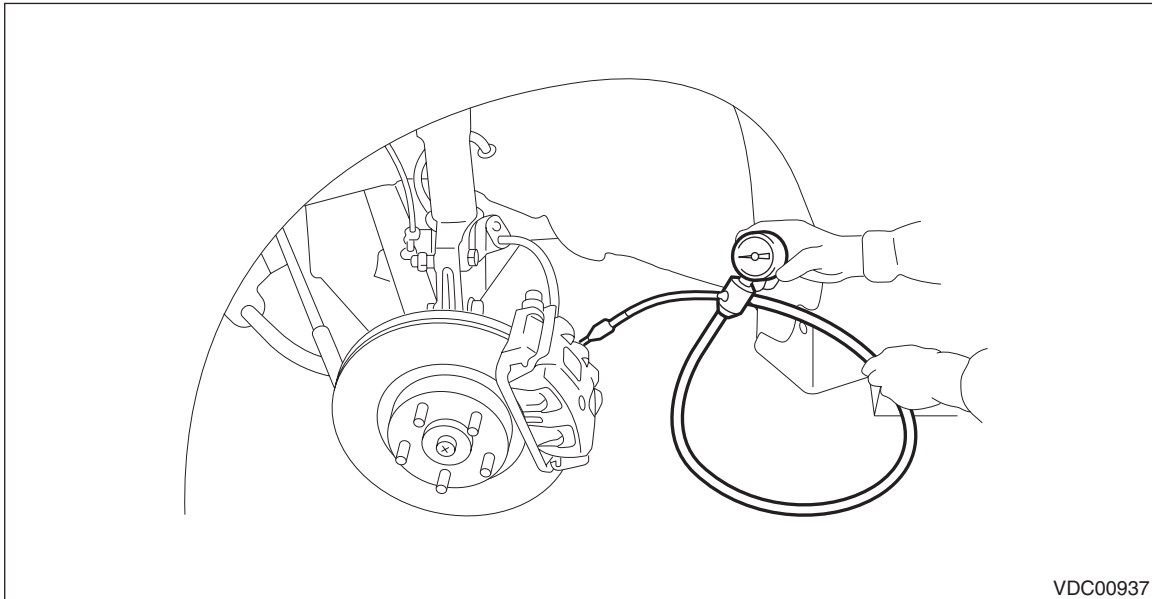

- 4) Bleed air from the pressure gauges and the FL and FR caliper bodies.
- 5) Perform ABS sequence control. <Ref. to VDC-20, ABS Sequence Control.>

NOTE:

When the hydraulic unit begins to work, first the FL side performs decompression, hold and compression, and then the FR side performs decompression, hold and compression.

- 6) Read values indicated on the pressure gauge and check if the fluctuation of the values between decompression and compression meets the standard values. Depress the brake pedal and check that the kick-back is normal, and tightness is normal.

Inspection conditions	Front wheel	Rear wheel
Initial value	3,500 kPa (36 kgf/cm ² , 511 psi)	3,500 kPa (36 kgf/cm ² , 511 psi)
When depressurized	500 kPa (5 kgf/cm ² , 73 psi) or less	500 kPa (5 kgf/cm ² , 73 psi) or less
When pressurized	3,500 kPa (36 kgf/cm ² , 511 psi) or more	3,500 kPa (36 kgf/cm ² , 511 psi) or more

- 7) Disconnect the pressure gauges from FL and FR caliper bodies.
- 8) Install the bleeder - screws of FL and FR caliper bodies.
- 9) Remove the bleeder - screws from RL and RR caliper bodies.
- 10) Connect two pressure gauges to RL and RR caliper bodies.
- 11) Bleed air from RL and RR caliper bodies, and pressure gauge.

12) Perform ABS sequence control. <Ref. to VDC-20, ABS Sequence Control.>

NOTE:

When the hydraulic unit begins to work, first the RR side performs decompression, hold and compression, and then the RL side performs decompression, hold and compression.

13) Read values indicated on the pressure gauge and check if the fluctuation of the values between decompression and compression meets specification. Depress the brake pedal and check that the kick-back is normal, and tightness is normal.

14) Disconnect the pressure gauge from the RL and RR caliper bodies.

15) Install the bleeder - screws of RL and RR caliper bodies.

16) Bleed air from the brake system. <Ref. to BR-59, Air Bleeding.>

2. CHECKING THE HYDRAULIC UNIT ABS OPERATION WITH THE BRAKE TESTER

1) Set wheels other than the one to measure on free rollers.

2) Prepare for the ABS sequence control operation. <Ref. to VDC-20, ABS Sequence Control.>

3) Set the front wheels or rear wheels on the brake tester (a) and set the gear to neutral.

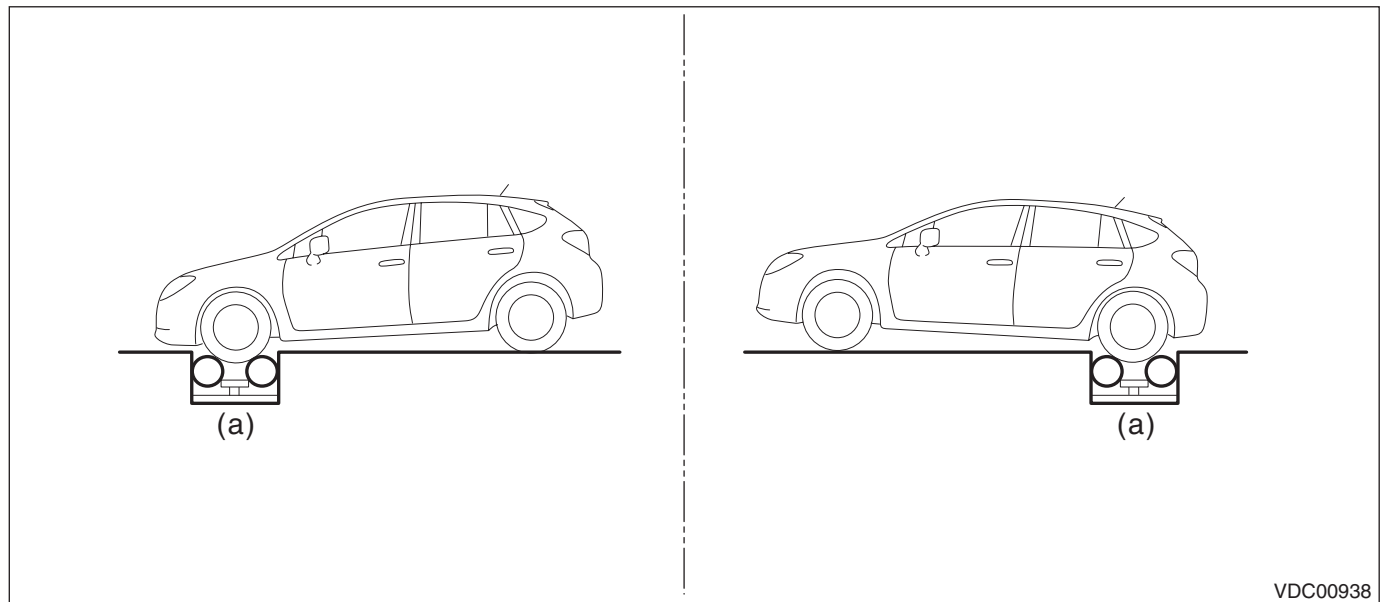

4) Operate the brake tester.

5) Perform ABS sequence control. <Ref. to VDC-20, ABS Sequence Control.>

6) When the hydraulic unit begins to work, check the following work sequence.

(1) The FL wheel performs decompression, hold and compression in sequence, and subsequently the FR wheel repeats the cycle.

(2) The RR wheel performs decompression, hold and compression in sequence, and subsequently the RL wheel repeats the cycle.

7) Read values indicated on the brake tester and check if the fluctuation of the values between decompression and compression meets specification.

Inspection conditions	Front wheel	Rear wheel
Initial value	1,000 N (102 kgf, 225 lb)	1,000 N (102 kgf, 225 lb)
When depressurized	500 N (51 kgf, 112 lb) or less	500 N (51 kgf, 112 lb) or less
When pressurized	1,000 N (102 kgf, 225 lb) or more	1,000 N (102 kgf, 225 lb) or more

8) After the inspection, depress the brake pedal and check that it is not abnormally hard, and tightness is normal.

VDC Control Module and Hydraulic Control Unit (VDCCM&H/U)

VEHICLE DYNAMICS CONTROL (VDC)

3. CHECKING THE HYDRAULIC UNIT VDC OPERATION USING A PRESSURE GAUGE

- 1) Lift up the vehicle, and then remove the wheel.
- 2) Remove the bleeder - screws from FL and FR caliper bodies.
- 3) Connect two pressure gauges to FL and FR caliper bodies.

CAUTION:

- Use a pressure gauge used exclusively for brake fluid measurement.
- Do not use a pressure gauge used for the measuring transmission oil pressure, as the piston seal may expand and deform.

NOTE:

Wrap sealing tape around the pressure gauge.

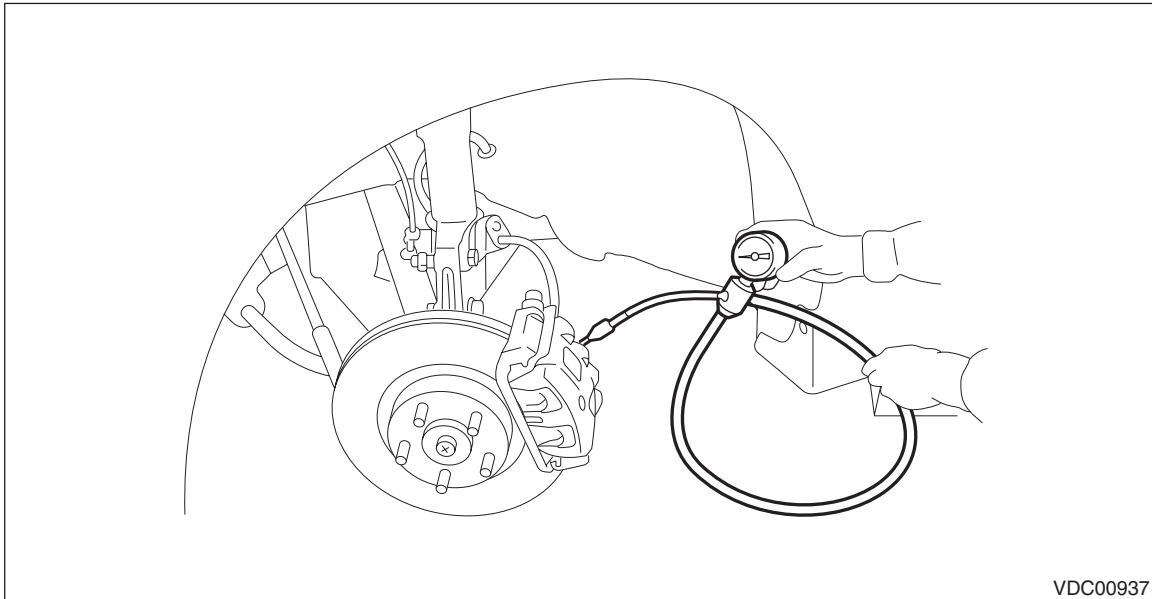

- 4) Bleed air from the pressure gauge.
- 5) Perform VDC sequence control. <Ref. to VDC-23, VDC Sequence Control.>

NOTE:

When the hydraulic unit begins to work, first the FL side performs compression, hold, and decompression, and then the FR side performs compression, hold, and decompression.

- 6) Read values indicated on the pressure gauge and check if the fluctuation of the values between decompression and compression meets specification. Depress the brake pedal and check that it is not abnormally hard, and tightness is normal.

Inspection conditions	Front wheel	Rear wheel
When pressurized	3,000 kPa (31 kgf/cm ² , 441 psi) or more	3,000 kPa (31 kgf/cm ² , 441 psi) or more
When depressurized	500 kPa (5 kgf/cm ² , 73 psi) or less	500 kPa (5 kgf/cm ² , 73 psi) or less

- 7) Disconnect the pressure gauges from FL and FR caliper bodies.
- 8) Install the bleeder - screws of FL and FR caliper bodies.
- 9) Remove the bleeder - screws from RL and RR caliper bodies.
- 10) Connect two pressure gauges to RL and RR caliper bodies.
- 11) Bleed air from RL and RR caliper bodies, and pressure gauge.

VDC Control Module and Hydraulic Control Unit (VDCCM&H/U)

VEHICLE DYNAMICS CONTROL (VDC)

12) Perform VDC sequence control. <Ref. to VDC-23, VDC Sequence Control.>

NOTE:

When the hydraulic unit begins to work, first the RR side performs compression, hold, and decompression, and then the RL side performs compression, hold, and decompression.

13) Read the values indicated on the pressure gauges and check if it is within specification. Depress the brake pedal and check that it is not abnormally hard, and tightness is normal.

14) Disconnect the pressure gauge from the RL and RR caliper bodies.

15) Install the bleeder - screws of RL and RR caliper bodies.

16) Bleed air from the brake system. <Ref. to BR-59, Air Bleeding.>

4. CHECK HYDRAULIC UNIT VDC OPERATION WITH BRAKE TESTER

1) Set wheels other than the one to measure on free rollers.

2) Prepare to operate the VDC sequence control. <Ref. to VDC-23, VDC Sequence Control.>

3) Set the front wheels or rear wheels on the brake tester (a) and set the gear to neutral.

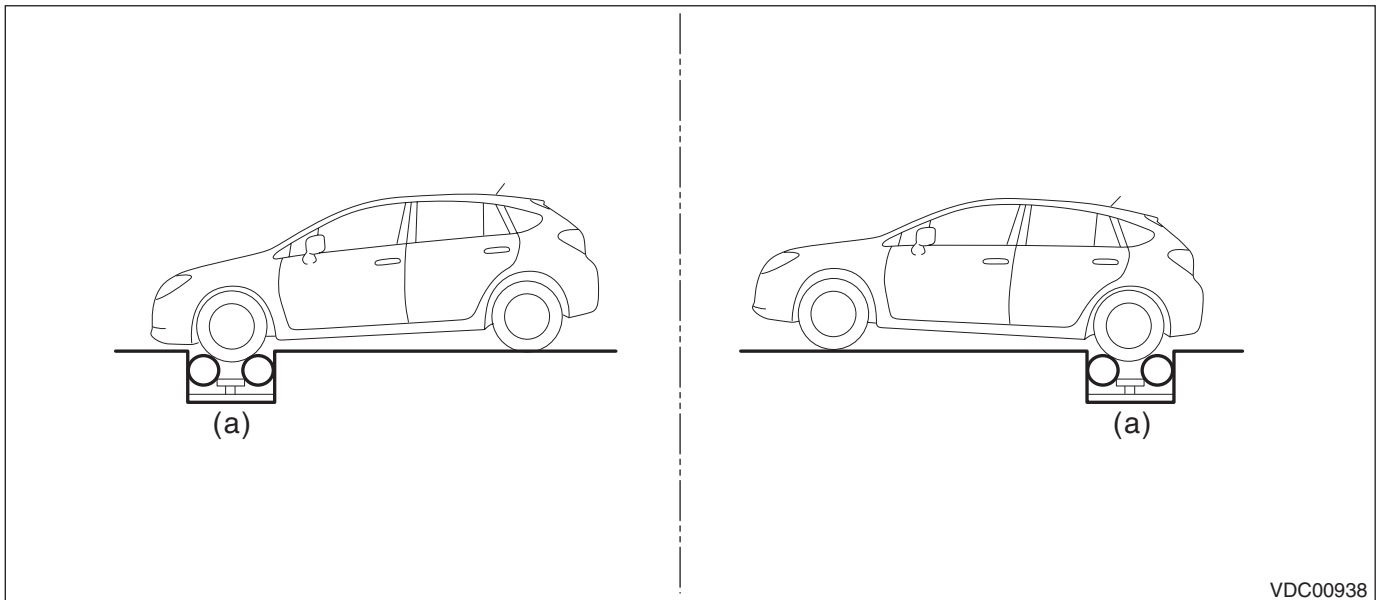

VDC00938

4) Operate the brake tester.

5) Perform VDC sequence control. <Ref. to VDC-23, VDC Sequence Control.>

6) When the hydraulic unit begins to work, check the following work sequence.

(1) The FL wheel performs compression, hold and decompression in sequence, and subsequently the FR wheel repeats the cycle.

(2) The RR wheel performs compression, hold and decompression in sequence, and subsequently the RL wheel repeats the cycle.

7) Read values indicated on the brake tester and check if the fluctuation of the values between decompression and compression meets specification.

Inspection conditions	Front wheel	Rear wheel
When pressurized	2,000 N (204 kgf, 450 lbf) or more	2,000 N (204 kgf, 450 lbf) or more
When depressurized	500 N (51 kgf, 112 lbf) or less	500 N (51 kgf, 112 lbf) or less

8) After the inspection, depress the brake pedal and check that it is not abnormally hard, and tightness is normal.

VDC Control Module and Hydraulic Control Unit (VDCCM&H/U)

VEHICLE DYNAMICS CONTROL (VDC)

D: REPLACEMENT

CAUTION:

- Because the pressure sensor built into the H/U is easily damaged by static electricity, start the operation after performing static electricity measures.
- Be careful not to touch the sensors in the H/U to prevent damage.
- Because the seal of the VDCCM cannot be replaced, do not pull or peel it by lifting it up.
- Because the screw of the H/U will become slightly worn in every replacement procedure, 5 times is the maximum number of times for replacement. If a problem is found such as not being able to torque the screw to specifications even before 5 replacement operations are performed, replace the H/U body.
- When installing the VDCCM, always use new screws.
- When the sealing surface of the VDCCM or H/U is dirty or damaged and it cannot be cleaned or repaired, replace with a new part.

1) Remove the VDCCM&H/U. <Ref. to VDC-9, REMOVAL, VDC Control Module and Hydraulic Control Unit (VDCCM&H/U).>

2) To prevent entry of foreign objects and brake fluid leakage, plug the oil pressure port of the VDCCM&H/U using a screw plug, etc.

3) Set the pump motor section of the removed VDCCM&H/U face down on a vise.

NOTE:

Before securing a part on a vise, place cushioning material such as wood blocks, aluminum plate, or cloth between the part and the vise.

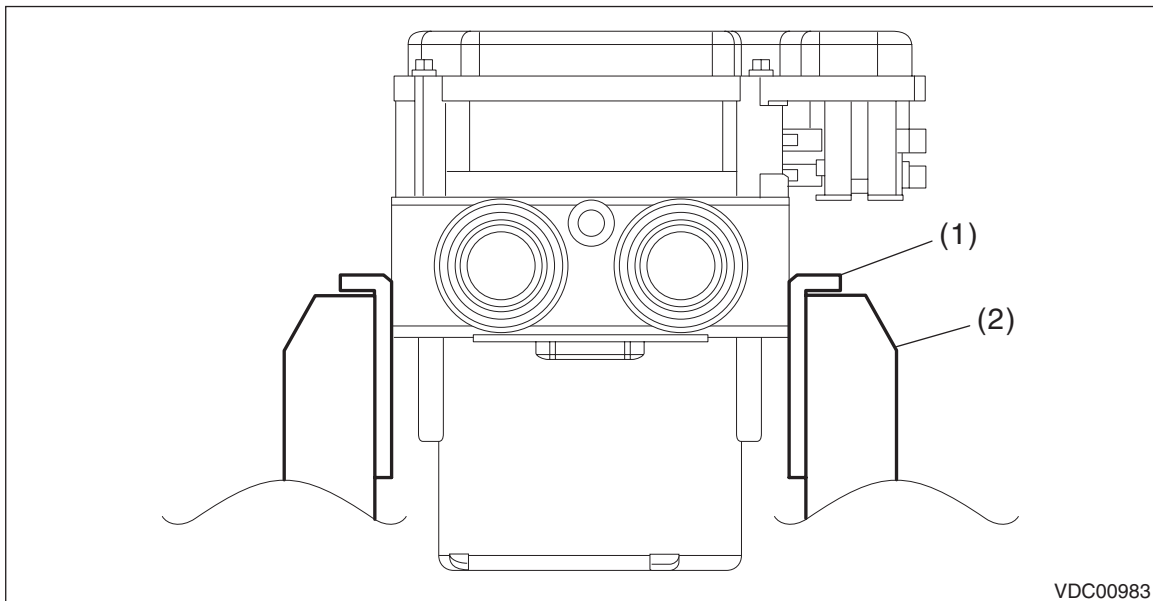

(1) Aluminum plate, etc.

(2) Vise

VDC Control Module and Hydraulic Control Unit (VDCCM&H/U)

VEHICLE DYNAMICS CONTROL (VDC)

4) Using TORX® bit E5, remove the four screws of VDCCM.

CAUTION:

Do not re-use the screws.

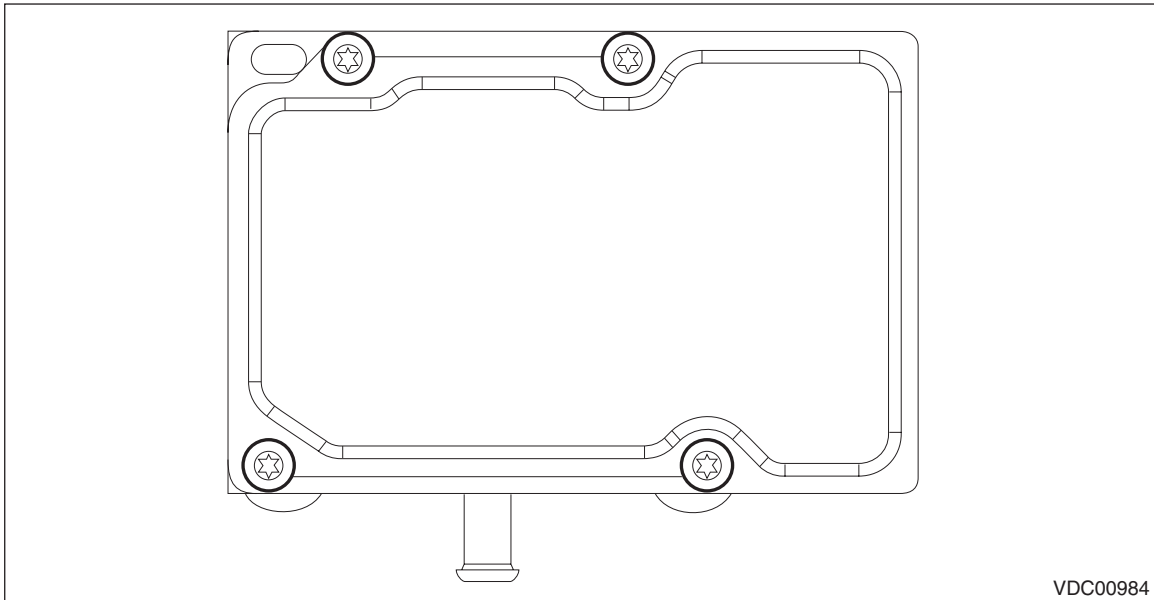

5) Slowly pull out the VDCCM upward from the H/U.

NOTE:

To prevent damaging of coil section, remove the VDCCM straight up from H/U without twisting.

6) Make sure there is no dirt or damage on the sealing surface of the H/U.

CAUTION:

- Do not clean the VDCCM&H/U by applying compressed air.
- Even if damage is found on the H/U seal, do not attempt repair by filing or with a metal scraper. To remove the seal residue, always use a plastic scraper. Do not use chemical such as paint thinner, etc., to clean.

7) Position the coil of the new VDCCM to align with the H/U valve.

8) To prevent deformation of the VDCCM housing cover, hold the corner of VDCCM and install it to the H/U without tilting.

VDC Control Module and Hydraulic Control Unit (VDCCM&H/U)

VEHICLE DYNAMICS CONTROL (VDC)

9) Using a TORX® bit E5, attach/tighten new screws in the order of (1) through (4).

CAUTION:

Always use new screws.

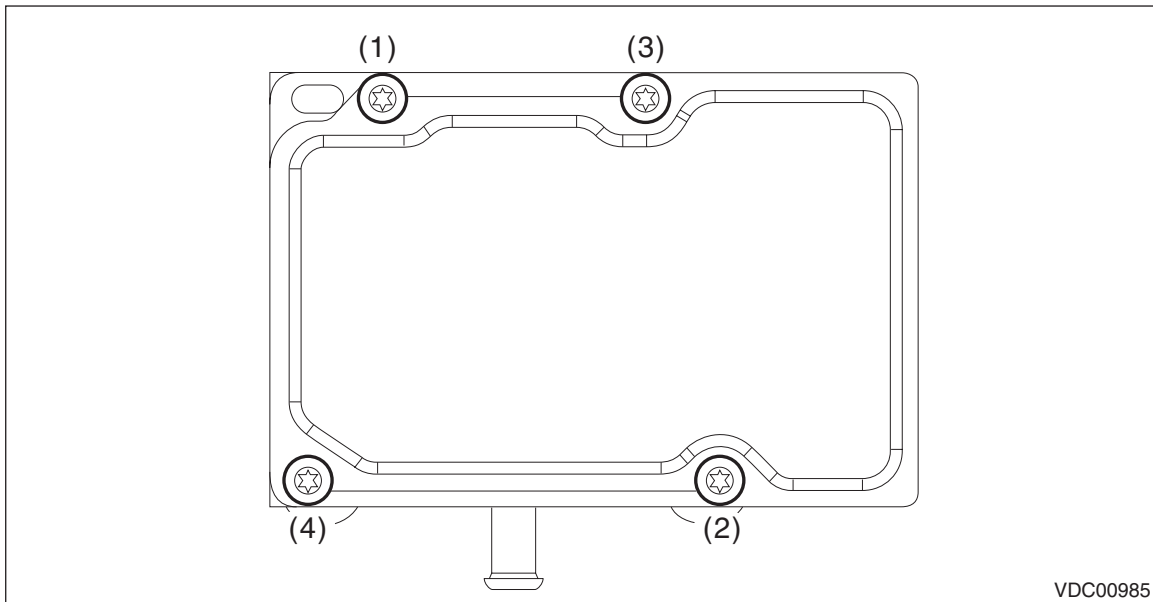

Tightening torque:

1.5 N·m (0.15 kgf·m, 1.1 ft·lb)

10) Check that there is no foreign matter in mating surface between the VDCCM&H/U.

11) Using a TORX® bit E5, tighten the screws in the order of (1) through (4) again.

Tightening torque:

3 N·m (0.31 kgf·m, 2.2 ft·lb)

12) Check that there is no gap in the mating surface between VDCCM&H/U.

13) Install the VDCCM&H/U to the vehicle.

CAUTION:

When installing the VDCCM&H/U, replace the damper - hydraulic unit, spacer and nut with new parts.

14) Bleed air from the brake system. <Ref. to BR-59, PROCEDURE, Air Bleeding.>

15) Perform the selection and registration operation of parameter. <Ref. to VDC(diag)-19, PARAMETER SELECTION, OPERATION, Subaru Select Monitor.>

NOTE:

- After replacing the VDCCM, be sure to perform the selection · registration operation of parameter.
- For the selection and registration of parameter, the Subaru Select Monitor is required.
- When the registration has not been performed, the DTC code “Parameter selection error” is detected together with the ABS/EBD/VDC warning light illumination.

16) Check the parameter to confirm that the applied models and grades of the relevant vehicle are included. <Ref. to VDC(diag)-19, PARAMETER CHECK, OPERATION, Subaru Select Monitor.>

17) If the applied models and grades of the relevant vehicle are not included, perform the selection · registration operation of parameter with the {Confirm on parameter} screen again. <Ref. to VDC(diag)-19, PARAMETER SELECTION, OPERATION, Subaru Select Monitor.>

18) Execute Clear Memory after parameter selection and registration operations because the DTC for “Parameter selection error” is memorized.

E: ADJUSTMENT

1. VDC SENSOR MIDPOINT SETTING MODE

After installing, replacing or adjusting the following parts, perform the VDC sensor midpoint setting mode.

- Steering angle sensor
 - Steering wheel
 - Suspension parts
 - Wheel alignment
 - VDCCM&H/U
 - VDCCM&H/U bracket
- 1) Park the vehicle on a level surface, and set the steering wheel to the neutral position.
 - 2) Connect the Subaru Select Monitor to data link connector.
 - (1) Run the “PC application for Subaru Select Monitor”.
 - (2) On «Main Menu» display, select {Each System Check}.
 - (3) Select {Brake Control System}. When {VDC} is displayed, select the [OK] button.
 - (4) From {Current Data Display & Save}, select {Steer Angle Sensor Op}, {Longitudinal G Sensor} and {Lateral G sensor Output}.
 - 3) Check that the steering angle sensor output value is between -10 and 10 deg.
 - 4) Check that output values for the longitudinal G sensor and lateral G sensor are $-2 \text{ — } 2 \text{ m/s}^2$.
 - 5) From {Work Support}, select {VDC sensor midpoint setting mode}, and perform the setting according to the procedure displayed on the Subaru Select Monitor Screen.
 - 6) Drive the vehicle for 10 minutes, and check that there is no system malfunction or the warning light illumination while driving.
 - 7) Make sure that the DTC is not stored.