

8. Steering Angle Sensor

A: REPLACEMENT

CAUTION:

When the steering wheel and steering angle sensor have been removed, perform “VDC sensor midpoint setting mode” of the VDC. <Ref. to VDC-19, VDC SENSOR MIDPOINT SETTING MODE, ADJUSTMENT, VDC Control Module and Hydraulic Control Unit (VDCCM&H/U).>

- 1) Position the front wheels straight ahead. (After moving a vehicle 5 m (16 ft) or more with front wheels positioned straight ahead, make sure that the vehicle moves straight ahead.)
- 2) Turn the ignition switch to OFF.
- 3) Disconnect the ground cable from battery and wait for at least 60 seconds before starting work.
- 4) Remove the driver’s airbag module.

CAUTION:

Before servicing the airbag module, always refer to “CAUTION” of “General Description” in the “AIR-BAG SYSTEM” section. <Ref. to AB-11, CAUTION, General Description.>

- (1) Using a hexagon wrench wrapped with protective tape, push in the snap pins to disengage the locks (3 places).

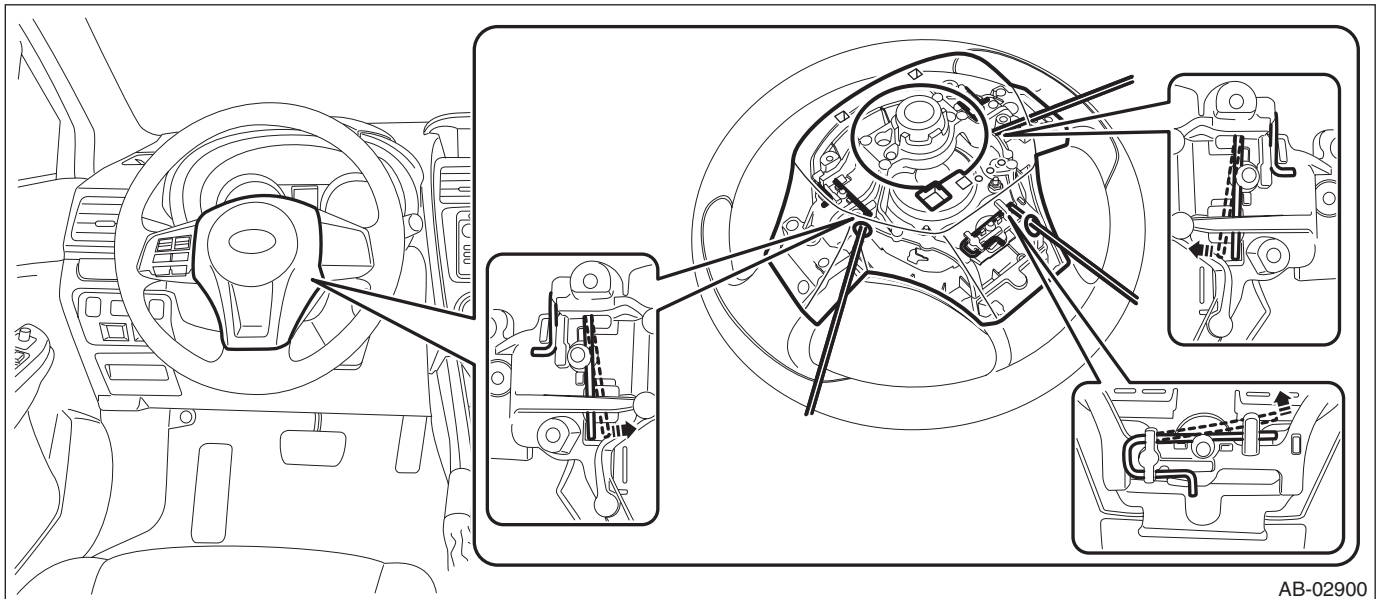

AB-02900

Steering Angle Sensor

VEHICLE DYNAMICS CONTROL (VDC)

(2) Disconnect the horn harness and airbag connector, and remove the airbag module. <Ref. to AB-24, DRIVER'S AIRBAG MODULE, CURTAIN AIRBAG MODULE & PRETENSIONER, PROCEDURE, Air-bag Connector.>

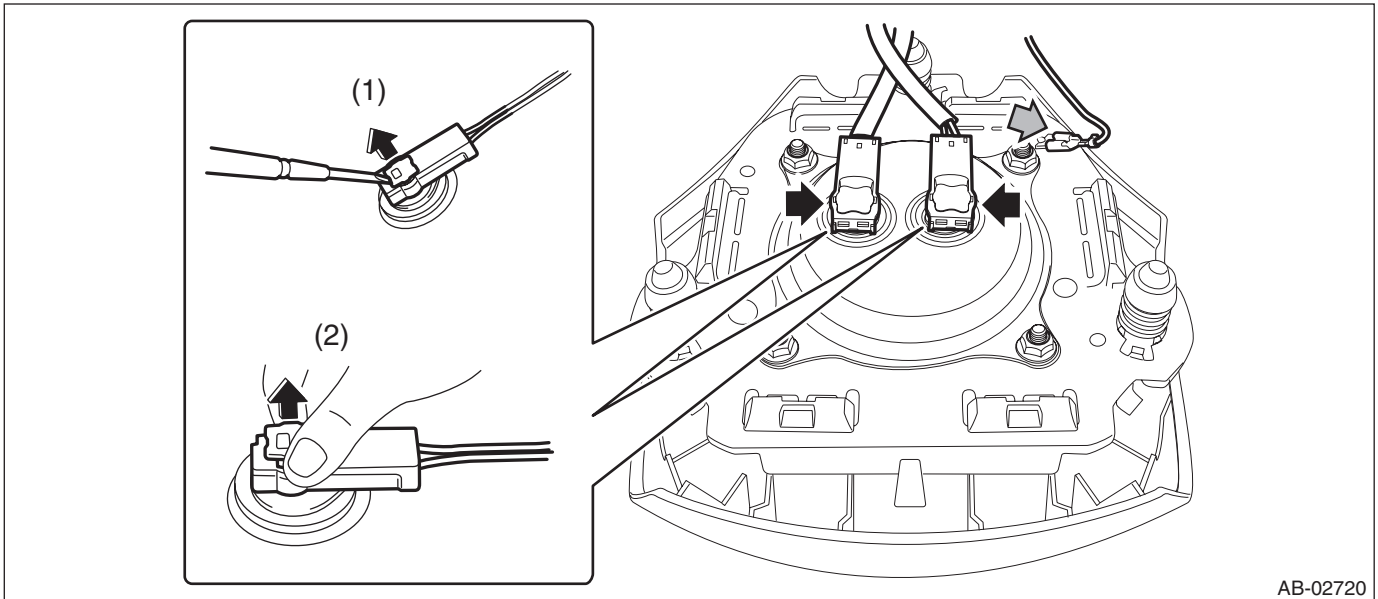

AB-02720

5) Remove the steering wheel.

CAUTION:

- Always use the steering wheel puller for removal to avoid deforming the steering wheel.
- If the steering wheel has been removed, make sure that the steering roll connector is not turned from the original position.

PREPARATION TOOL:

Steering wheel puller

- (1) Disconnect the connector and remove the nut.
- (2) Put alignment marks and remove the steering wheel.

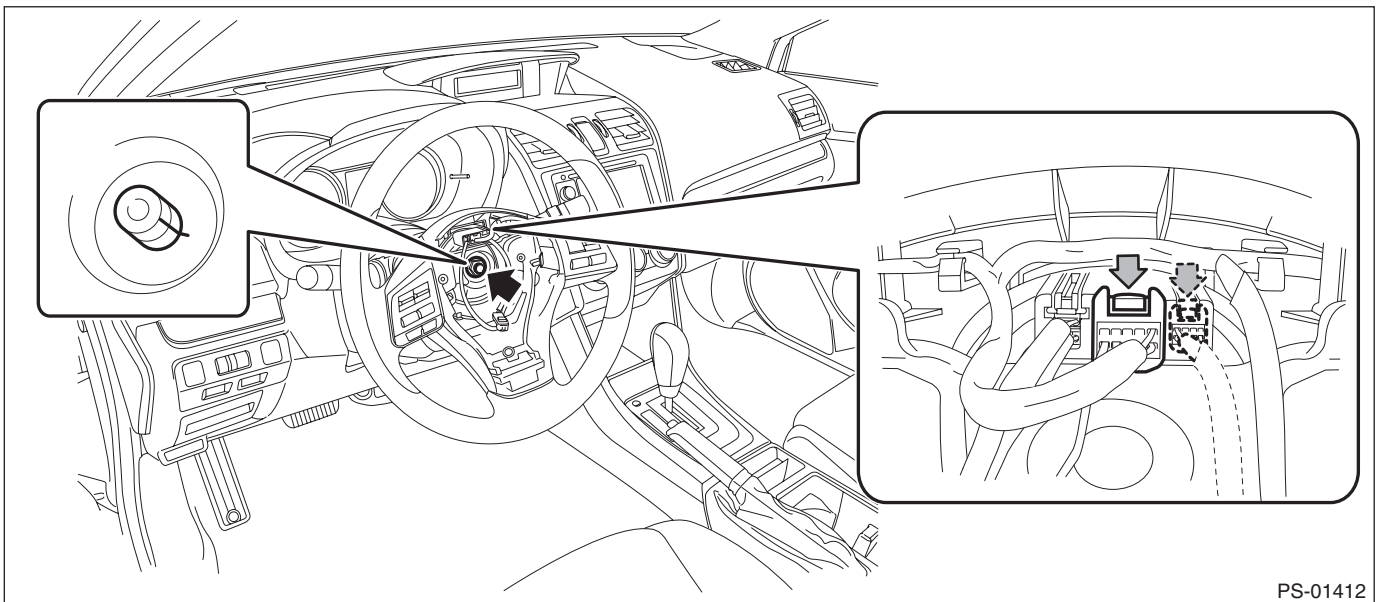

PS-01412

Steering Angle Sensor

VEHICLE DYNAMICS CONTROL (VDC)

6) Remove the cover assembly - column.

- (1) Release the screw and claw, and remove the cover assembly - column UPR and the cover assembly - column LWR.

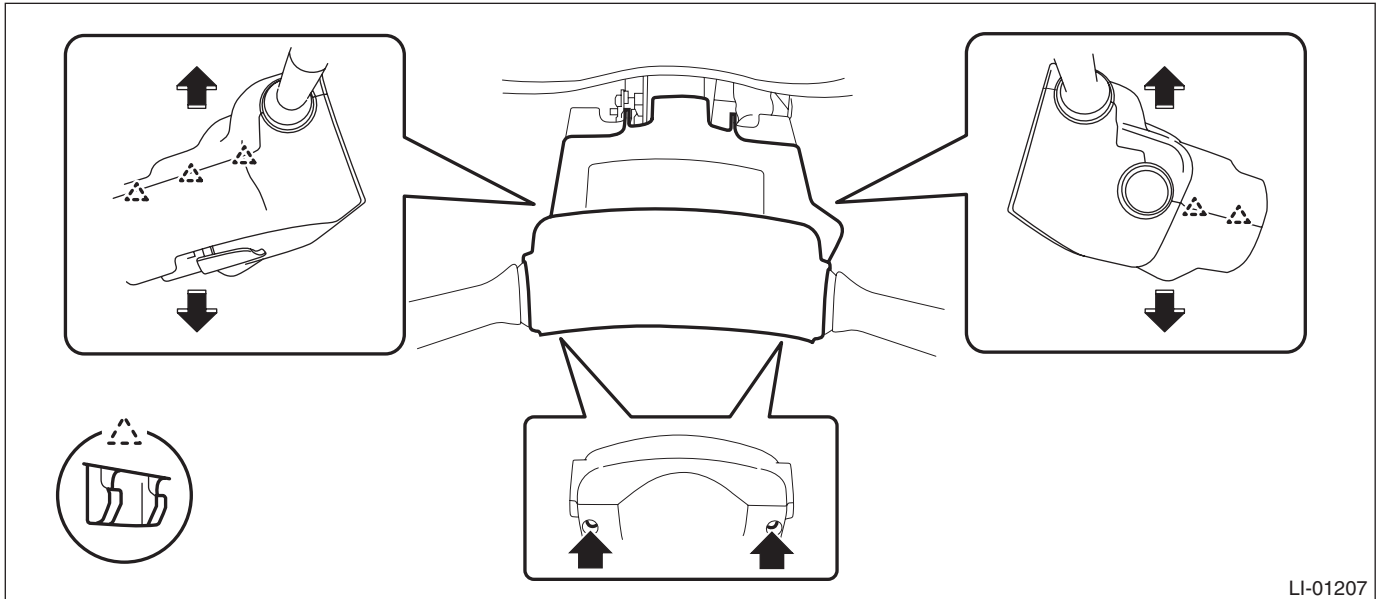

LI-01207

7) Remove the steering roll connector.

CAUTION:

Make sure that the steering roll connector is not turned from the original position.

- (1) Disconnect the connector under the steering roll connector.
- (2) Release the claws and remove the steering roll connector.

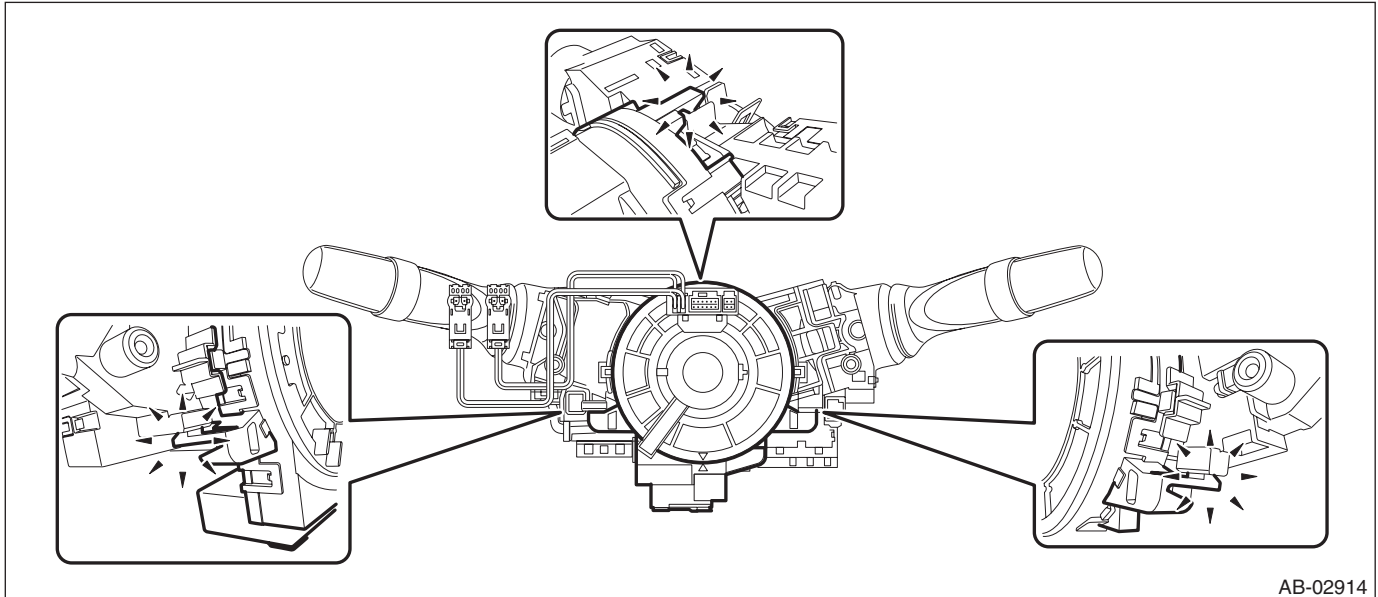

AB-02914

Steering Angle Sensor

VEHICLE DYNAMICS CONTROL (VDC)

8) Remove the steering angle sensor.

(1) Release the claws and remove the steering angle sensor (b) from the steering roll connector (a).

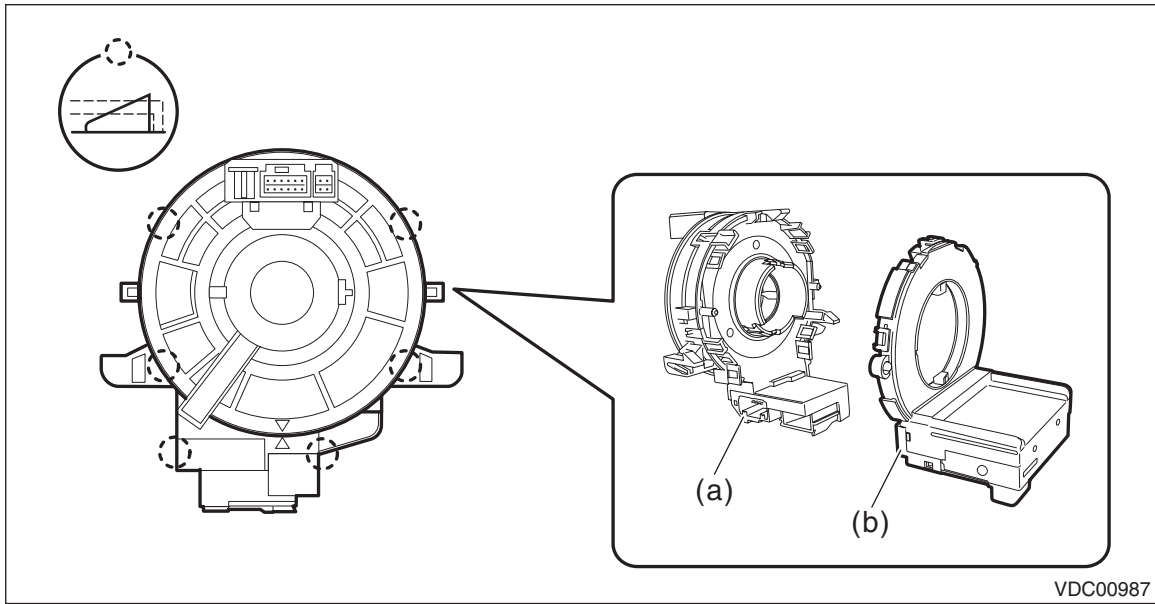

9) Install the steering angle sensor.

(1) Apply grease to the protrusion (a) of new steering angle sensor.

CAUTION:

Do not rotate the steering angle sensor protrusion.

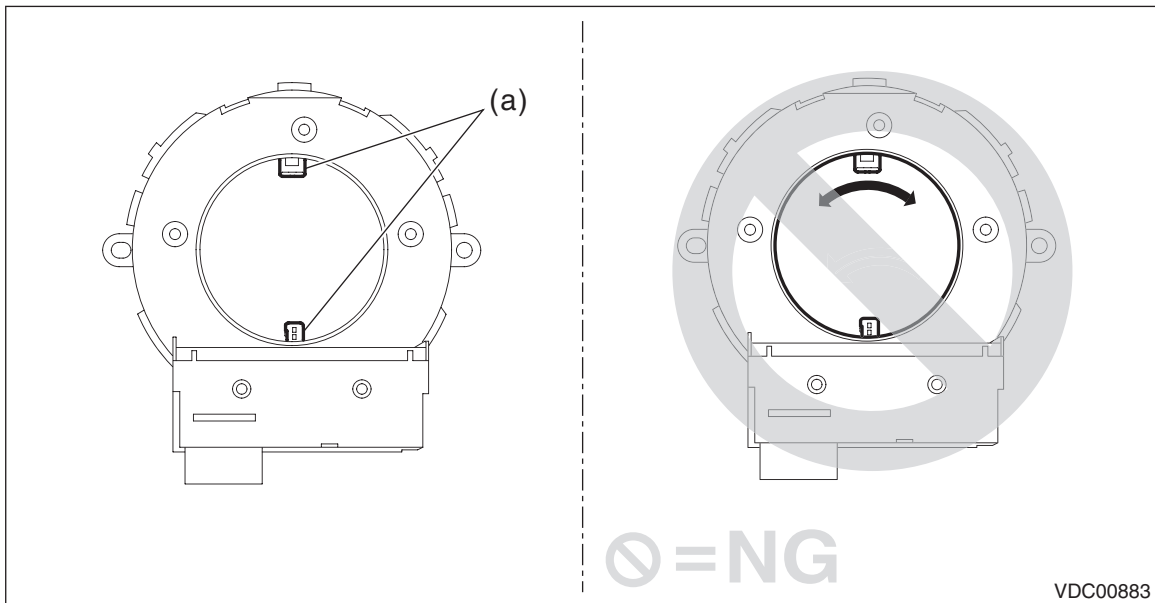

(2) Align the center of steering roll connector. <Ref. to AB-107, INSTALLATION, Roll Connector.>

(3) Align the position of the protrusion and install the steering angle sensor to the steering roll connector.

10) Install each part in the reverse order of removal.

Tightening torque:

Steering wheel: 39 N·m (3.98 kgf·m, 28.8 ft·lb)

Clearance:

Cover assembly - column to steering wheel: 4 — 6 mm (0.16 — 0.24 in)

11) After installation, perform the neutral position setting of the steering angle sensor. <Ref. to VDC-19, VDC SENSOR MIDPOINT SETTING MODE, ADJUSTMENT, VDC Control Module and Hydraulic Control Unit (VDCCM&H/U).>