

Rear ABS Wheel Speed Sensor

VEHICLE DYNAMICS CONTROL (VDC)

10. Rear ABS Wheel Speed Sensor

A: REMOVAL

1. 4 DOOR MODEL

- 1) Disconnect the ground cable from battery.
- 2) Lift up the vehicle, and then remove the rear wheels.
- 3) Remove the rear ABS wheel speed sensor.

CAUTION:

- Be careful not to damage the sensor.
- Do not apply excessive force to the sensor harness.
- Leave the sensor harness clamp on the vehicle side.
 - (1) Take out the trunk mat.
 - (2) Tilt the backrest assembly of the rear seat forward.
 - (3) Remove the clips located at the bottom of the cover COMPL - rear backrest LH and RH of the rear seat back.

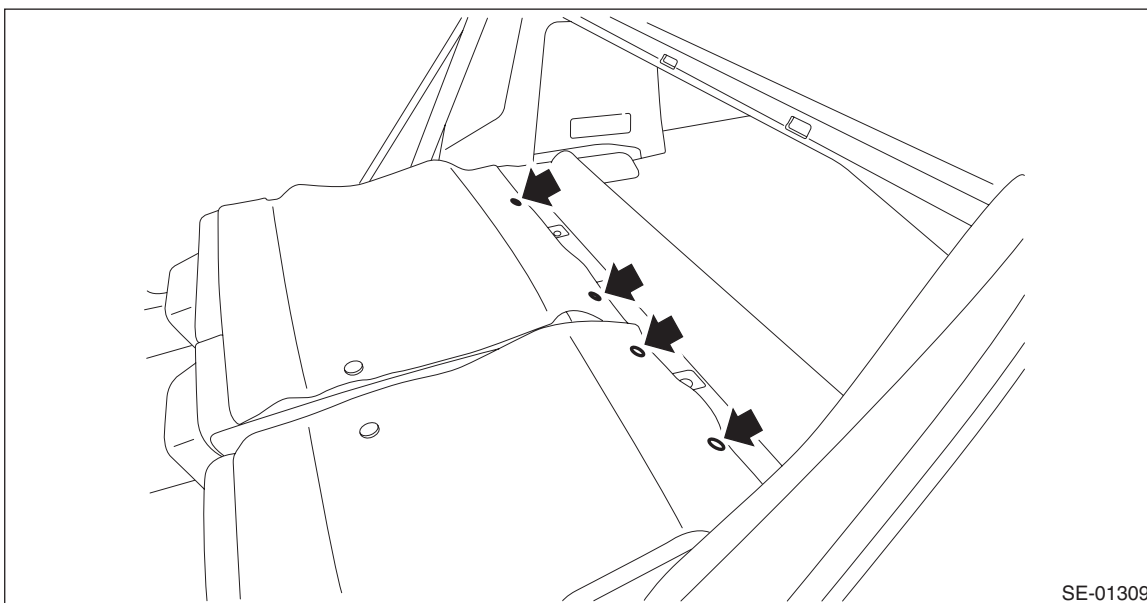

- (4) Remove the clips, and turn over the trim panel - trunk side.

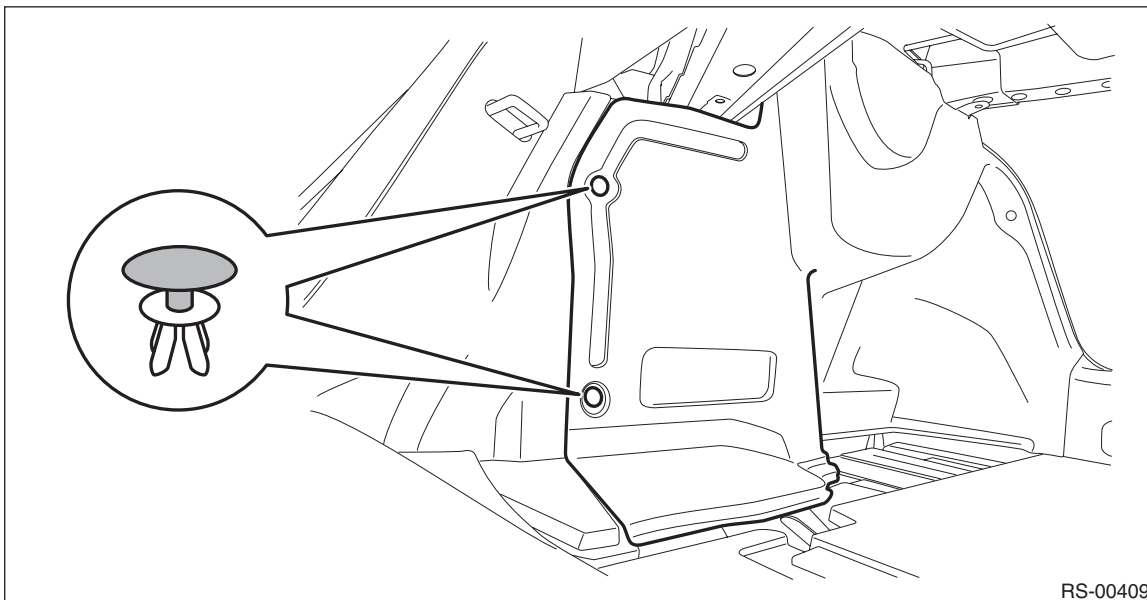

Rear ABS Wheel Speed Sensor

VEHICLE DYNAMICS CONTROL (VDC)

- (5) Disconnect the connector of the rear ABS wheel speed sensor.

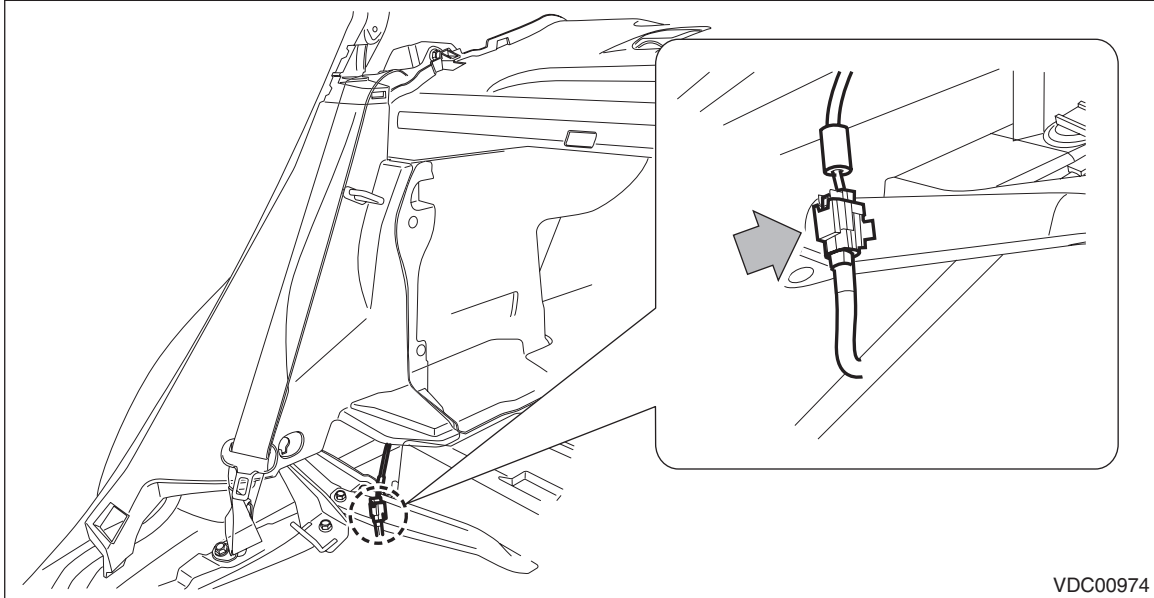

- (6) Remove the grommet from the rear wheel housing, and pull out the connector of the rear ABS wheel speed sensor.

- (7) Remove the harness clip and bolt, and remove the rear ABS wheel speed sensor.

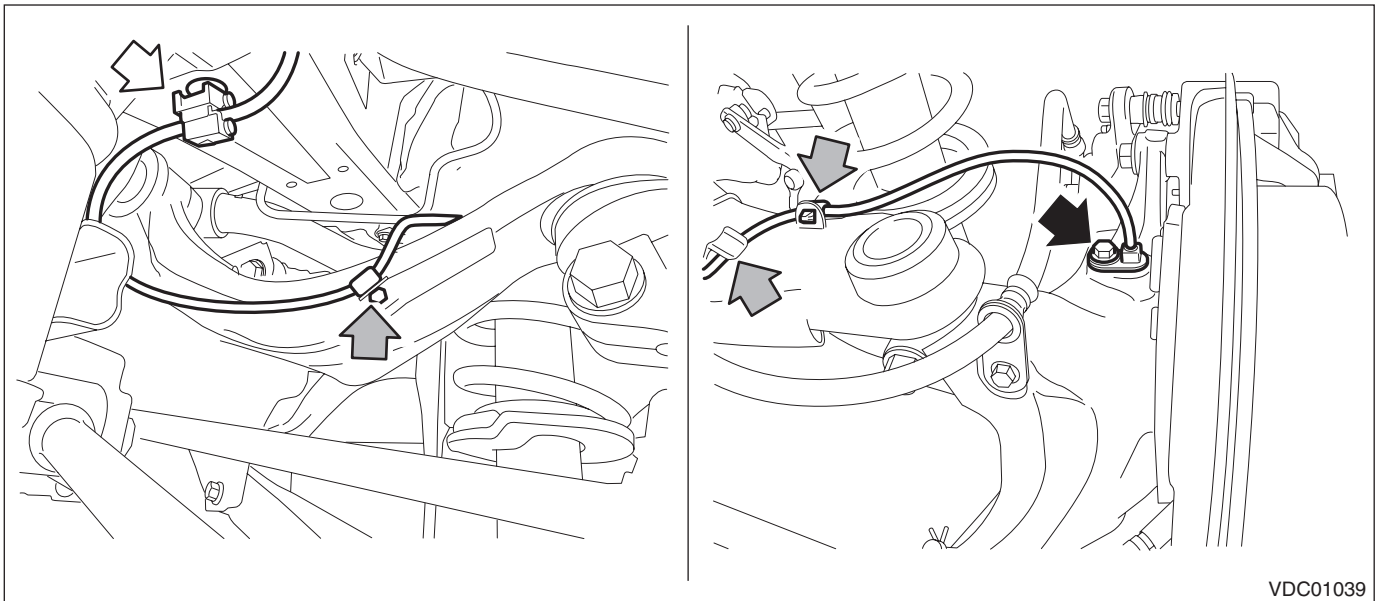

Rear ABS Wheel Speed Sensor

VEHICLE DYNAMICS CONTROL (VDC)

2. 5 DOOR MODEL/XV MODEL

- 1) Disconnect the ground cable from battery.
- 2) Lift up the vehicle, and then remove the rear wheels.
- 3) Remove the rear ABS wheel speed sensor.

CAUTION:

- Be careful not to damage the sensor.
- Do not apply excessive force to the sensor harness.
- Leave the sensor harness clamp on the vehicle side.

- (1) Tilt the backrest assembly of the rear seat forward.
- (2) Remove the clips located at the bottom of the cover COMPL - rear backrest LH and RH of the rear seat back.

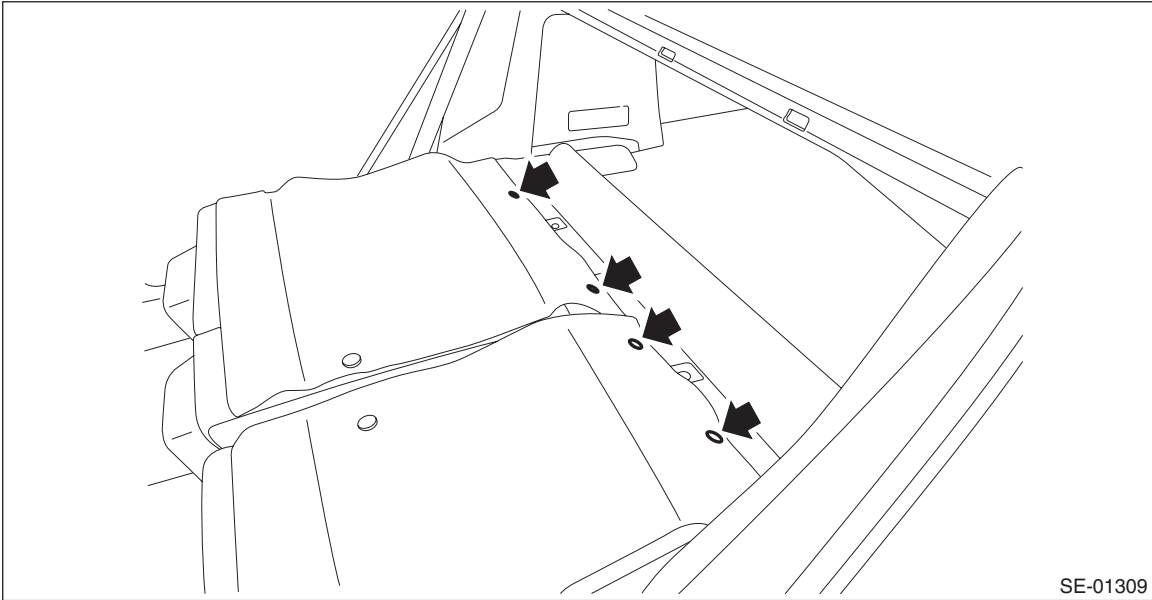

- (3) Remove the mat - rear floor CTR and the spacer - rear floor side.

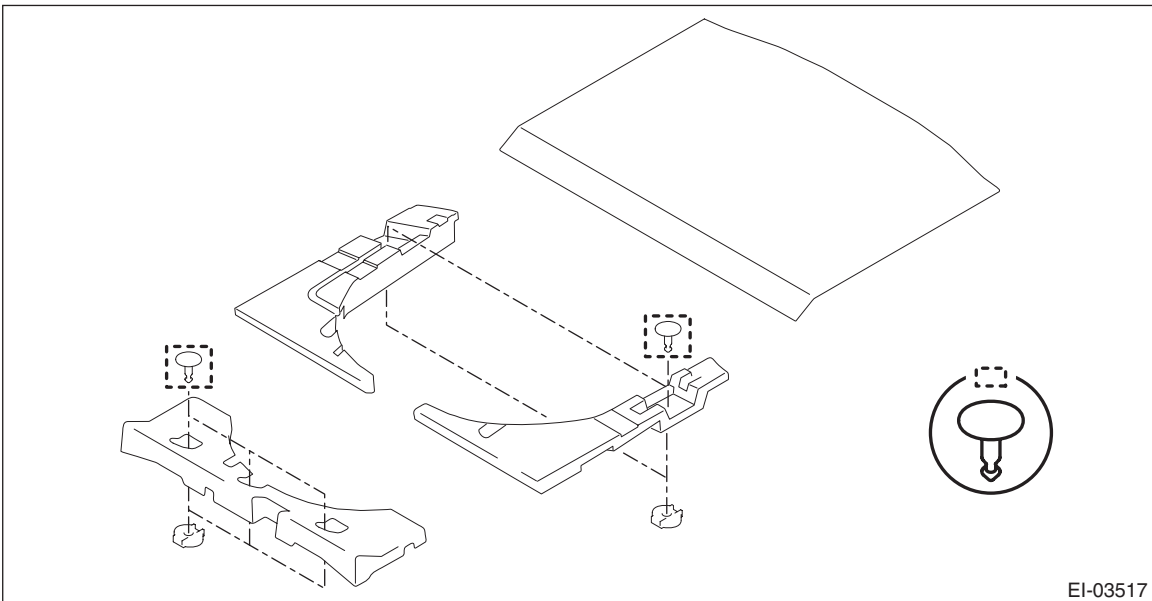

Rear ABS Wheel Speed Sensor

VEHICLE DYNAMICS CONTROL (VDC)

(4) Remove the clips, and remove the trim panel - rear skirt.

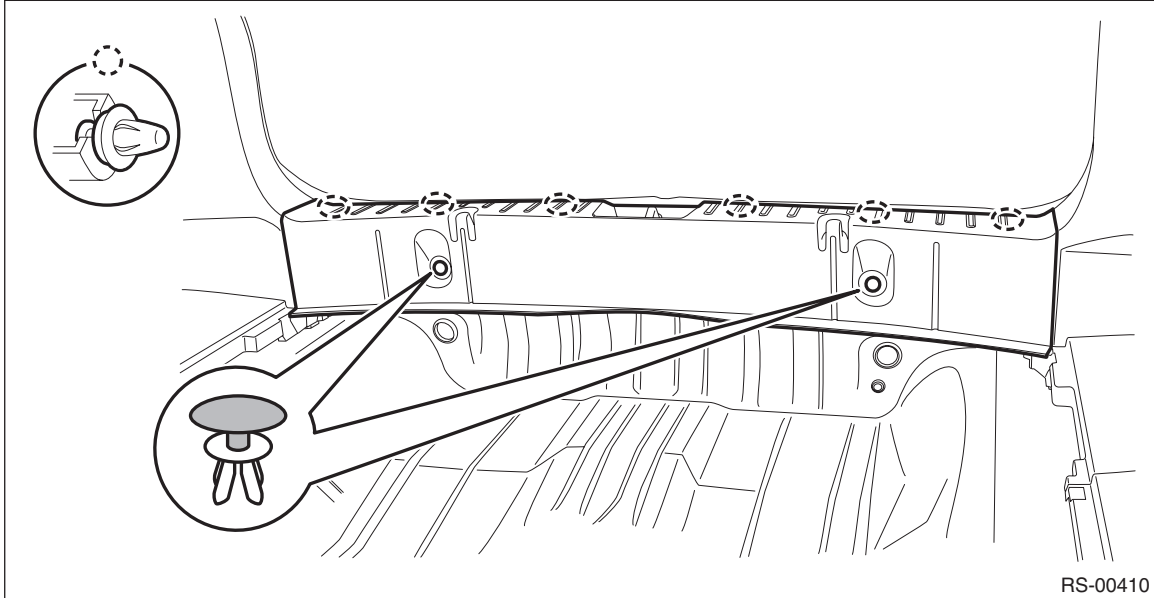

(5) Remove the lid upper rear (a) and the cap - rear strut (b) in the order from (1) to (6).

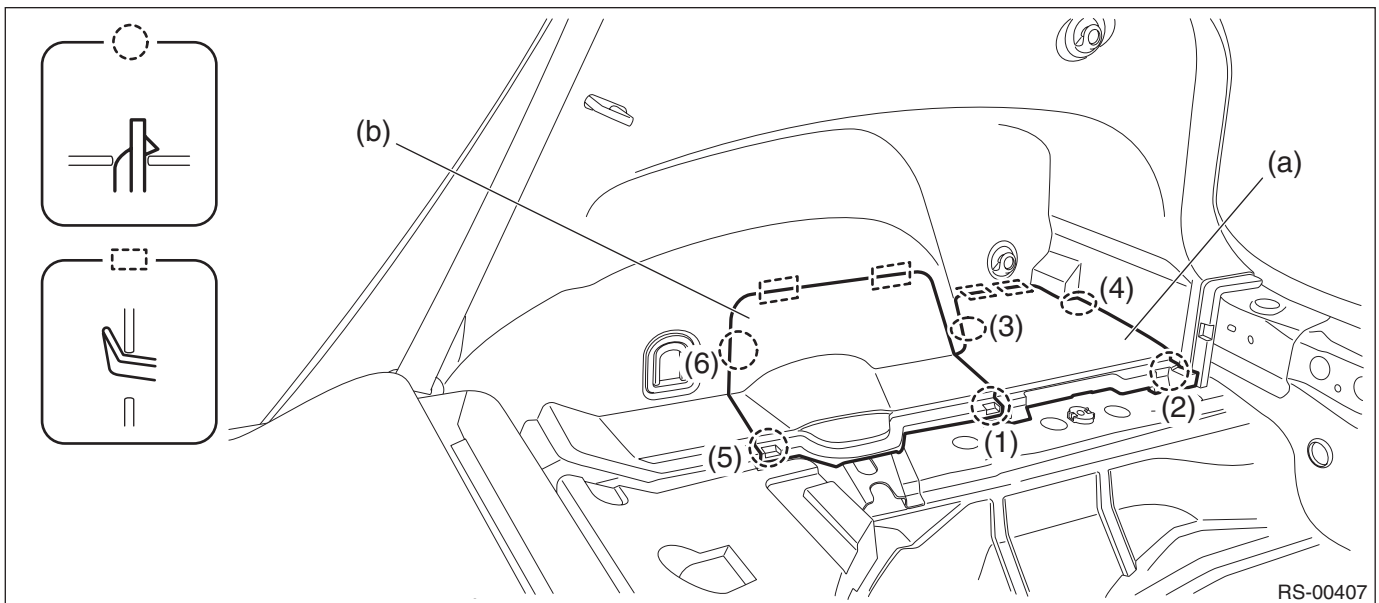

Rear ABS Wheel Speed Sensor

VEHICLE DYNAMICS CONTROL (VDC)

(6) Disconnect the connector of the rear ABS wheel speed sensor.

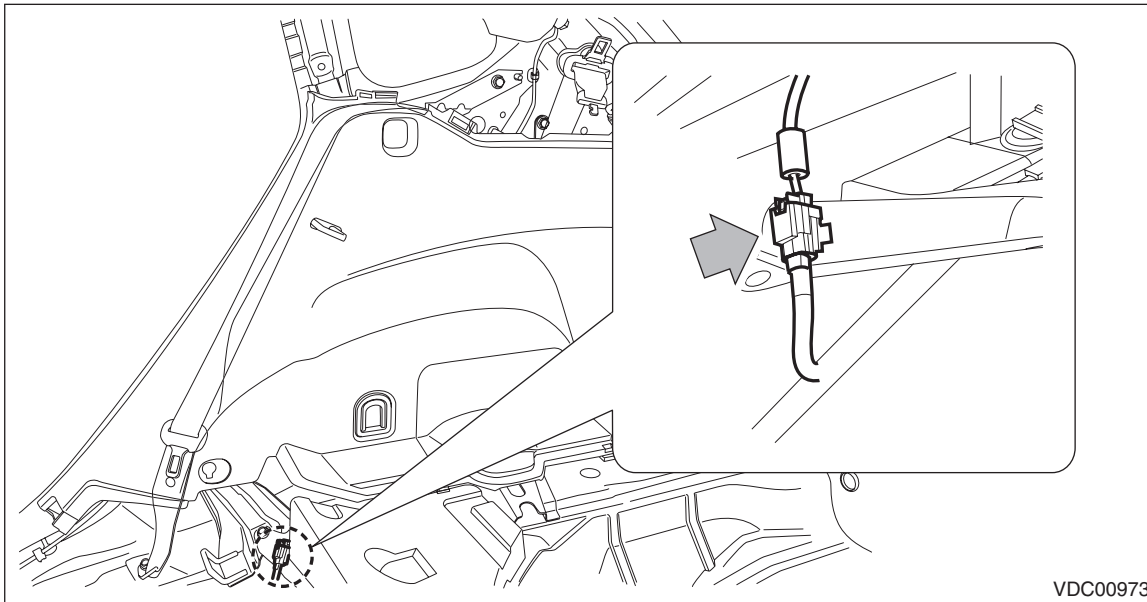

(7) Remove the grommet from the rear wheel housing, and pull out the connector of the rear ABS wheel speed sensor.

(8) Remove the harness clip and bolt, and remove the rear ABS wheel speed sensor.

- Except for XV model

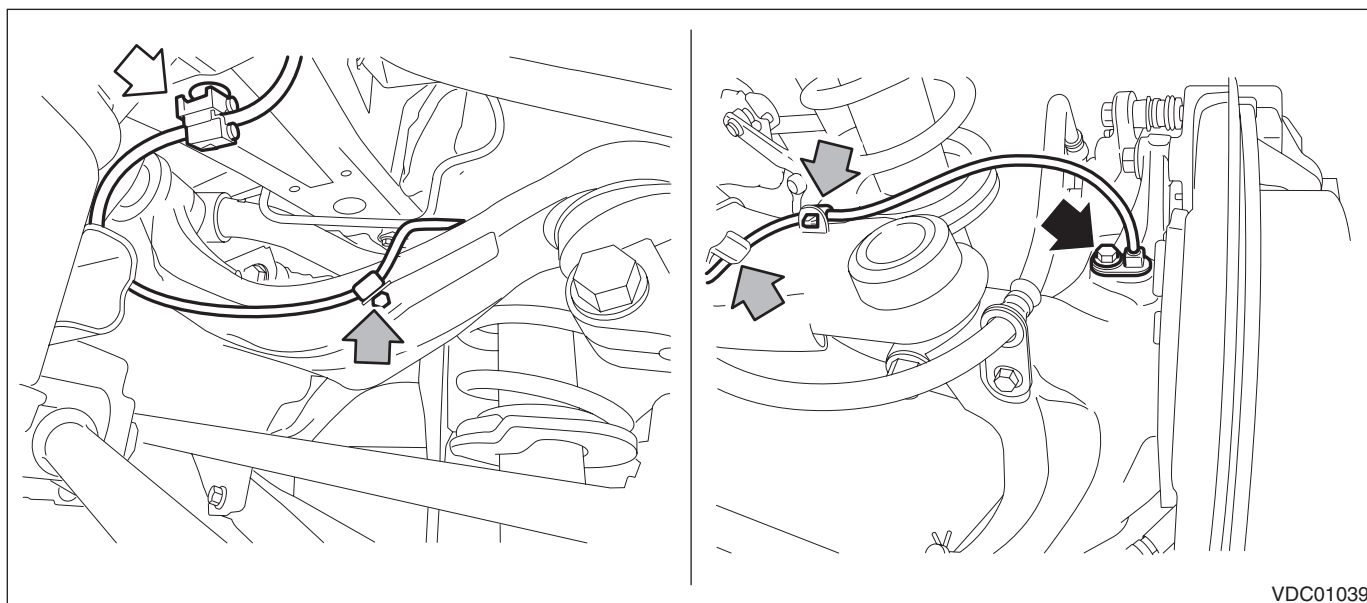

Rear ABS Wheel Speed Sensor

VEHICLE DYNAMICS CONTROL (VDC)

- XV model

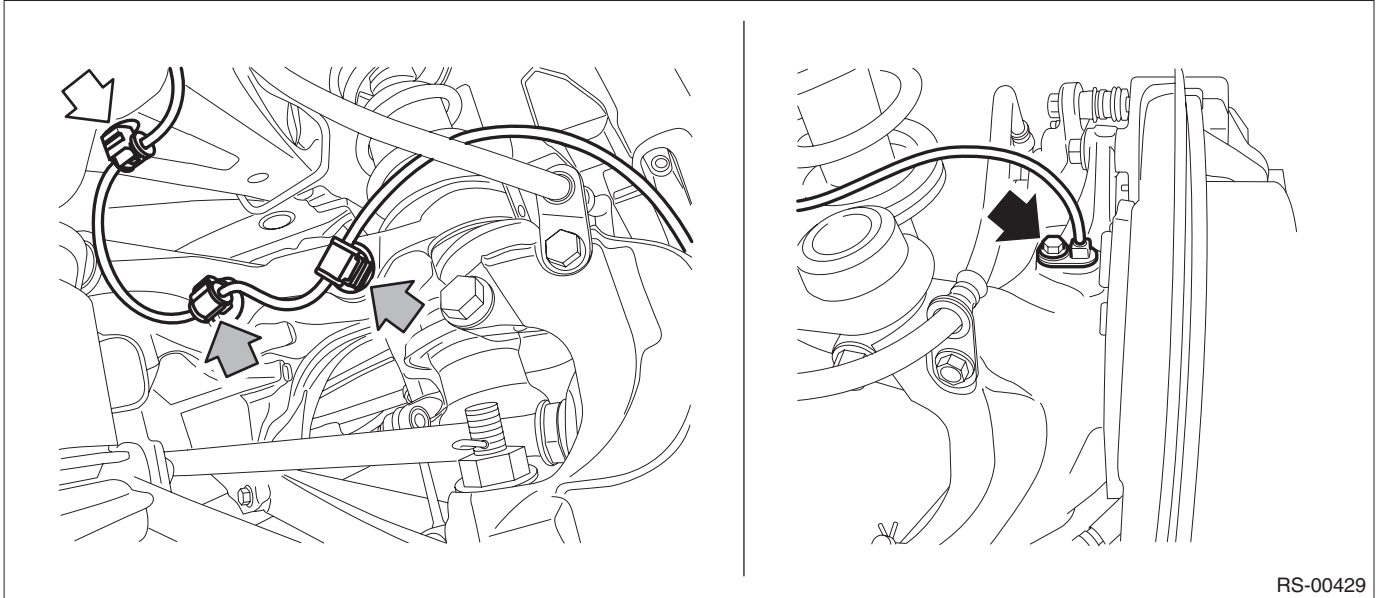

B: INSTALLATION

CAUTION:

Be careful not to damage the sensor.

- 1) Install each part in the reverse order of removal.
- 2) Route the rear ABS wheel speed sensor cable to the upper arm assembly.

NOTE:

Check the identification (mark) on the harness to make sure there is no warpage. <Ref. to VDC-2, SPECIFICATION, General Description.>

Tightening torque:

Rear ABS wheel speed sensor: 7.5 N·m (0.76 kgf-m, 5.5 ft-lb)

Rear wheel: 120 N·m (12.24 kgf-m, 88.5 ft-lb)

C: INSPECTION

1. ABS WHEEL SPEED SENSOR

For inspection of rear ABS wheel speed sensor, refer to inspection of front ABS wheel speed sensor. <Ref. to VDC-33, CHECK ABS WHEEL SPEED SENSOR UNIT, INSPECTION, Front ABS Wheel Speed Sensor.>