

Throttle Body

FUEL INJECTION (FUEL SYSTEMS)

2. Throttle Body

A: REMOVAL

- 1) Disconnect the ground cable from battery.

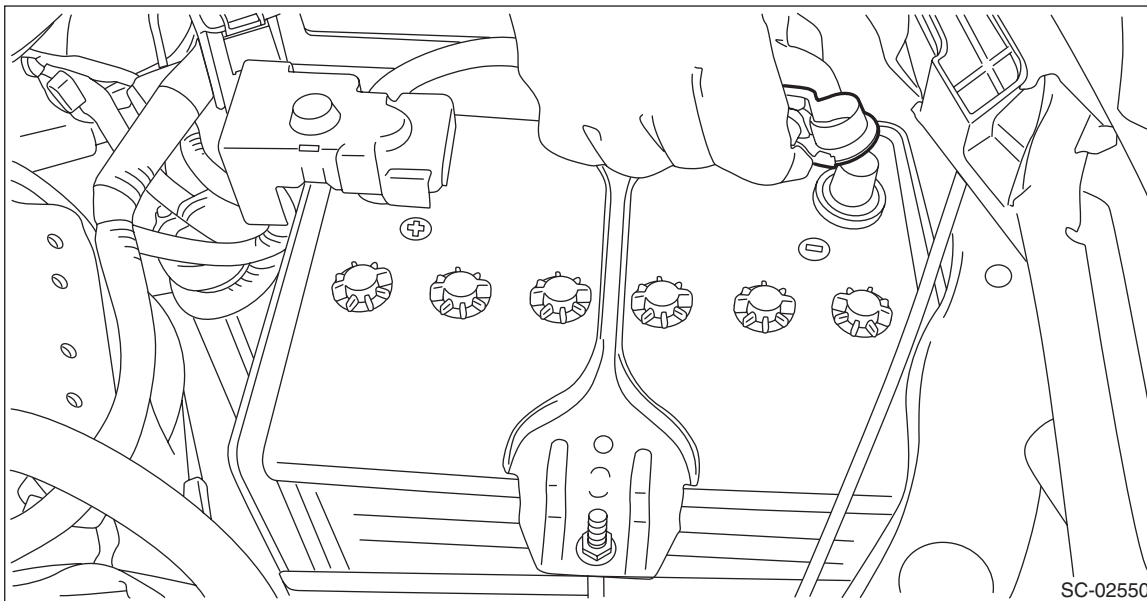

- 2) Lift up the vehicle.
- 3) Remove the under cover. <Ref. to EI-27, REMOVAL, Front Under Cover.>
- 4) Drain approximately 3.0 L (3.2 US qt, 2.6 Imp qt) of coolant. <Ref. to CO(H4DO)-13, DRAINING OF ENGINE COOLANT, REPLACEMENT, Engine Coolant.>
- 5) Remove the clip (A) from the air intake boot.
- 6) Loosen the clamp (B) connecting the air intake boot and air cleaner case (rear).
- 7) Loosen the clamp (C) which connects the air intake boot and throttle body.

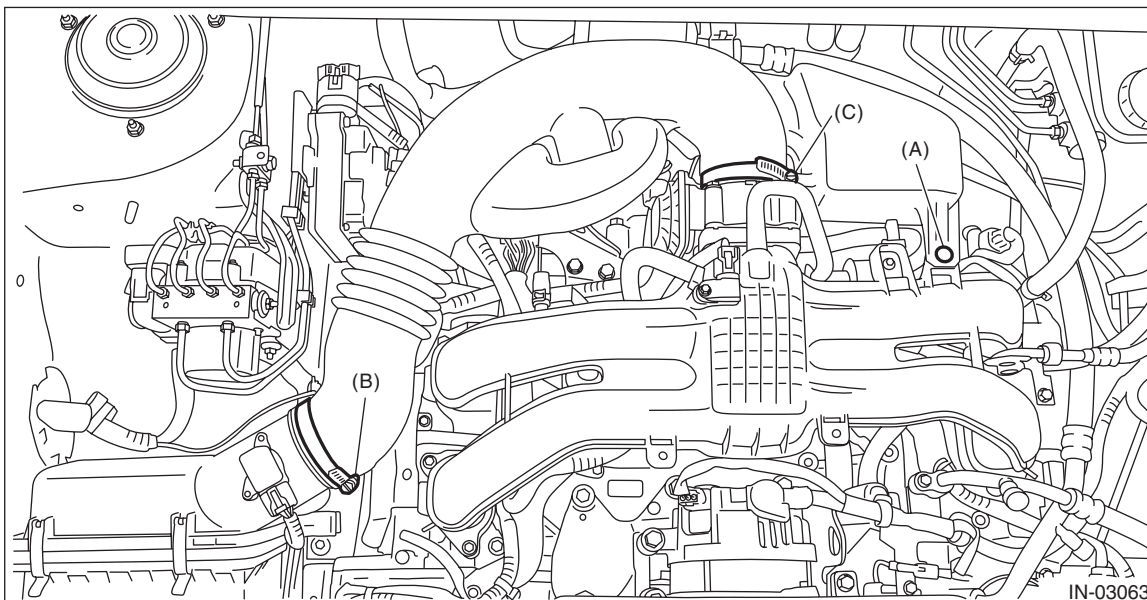

Throttle Body

- 8) Remove the air intake boot from the throttle body, and move it to the left side wheel apron.

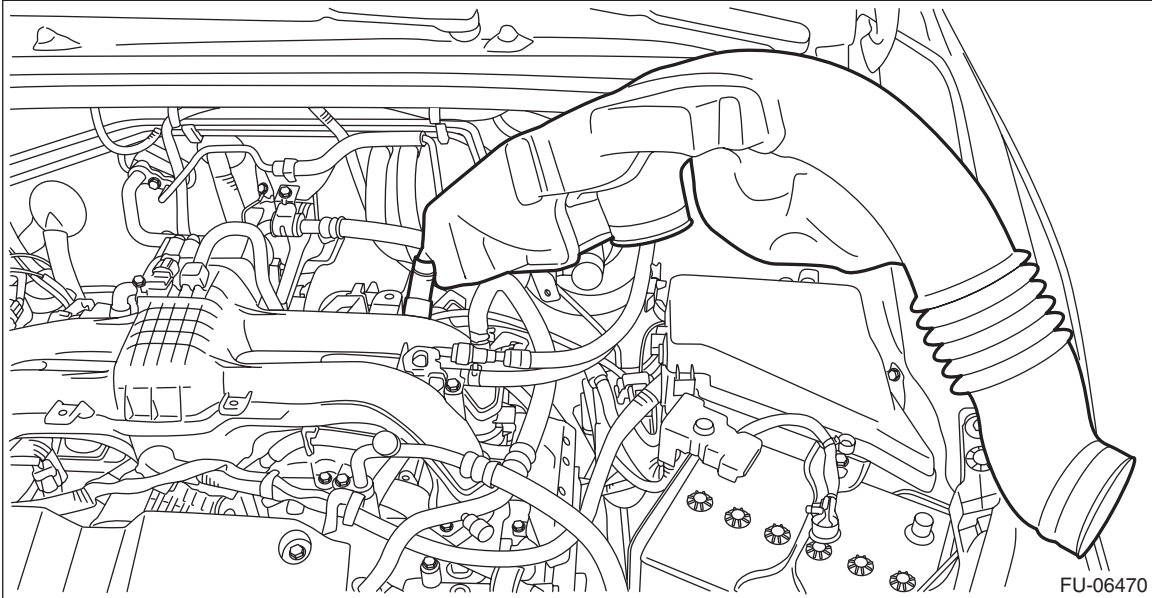

- 9) Disconnect the connectors (A) from the throttle position sensor.
10) Disconnect the preheater hose (B) from the throttle body.

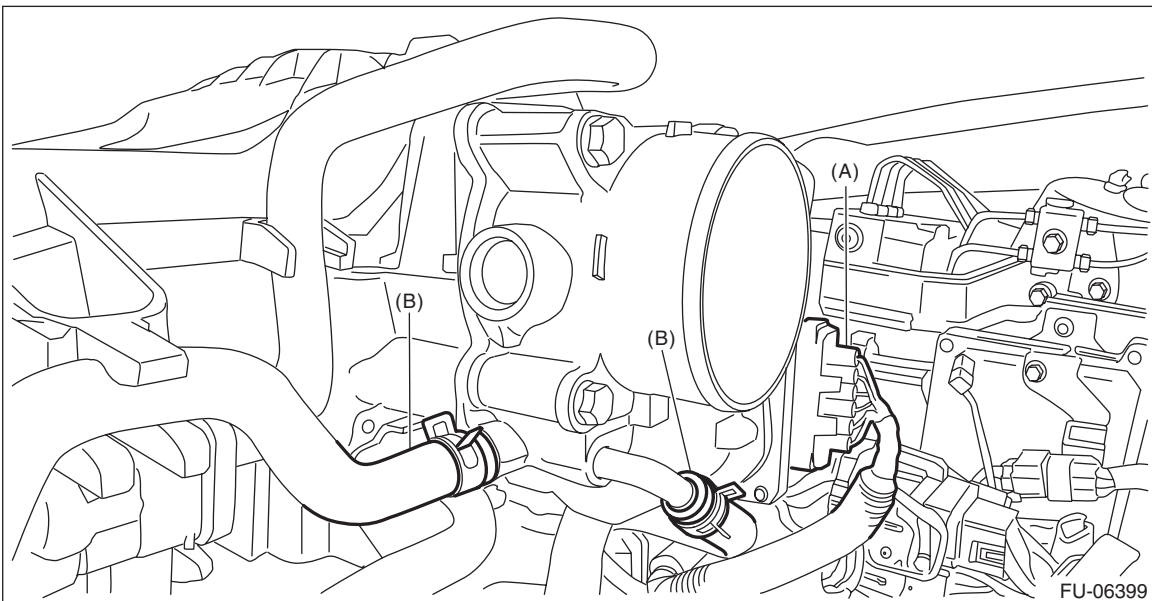

Throttle Body

FUEL INJECTION (FUEL SYSTEMS)

11) Remove the throttle body from the intake manifold.

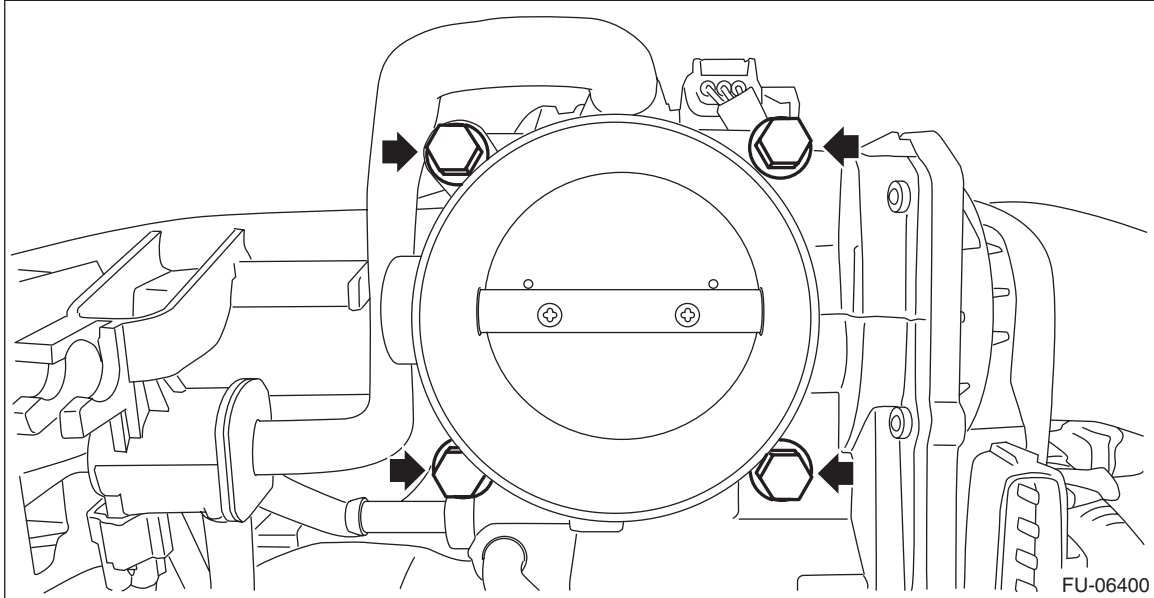

B: INSTALLATION

Install in the reverse order of removal.

NOTE:

Use a new gasket.

Tightening torque:

8 N·m (0.8 kgf·m, 5.9 ft·lb)

C: INSPECTION

1. THROTTLE SENSOR (METHOD WITH CIRCUIT TESTER)

- 1) Remove the back panel - pocket. <Ref. to EI-67, REMOVAL, Glove Box.>
- 2) Turn the ignition switch to ON. (engine OFF)
- 3) Measure the voltage between ECM connector terminals.



FU-06445

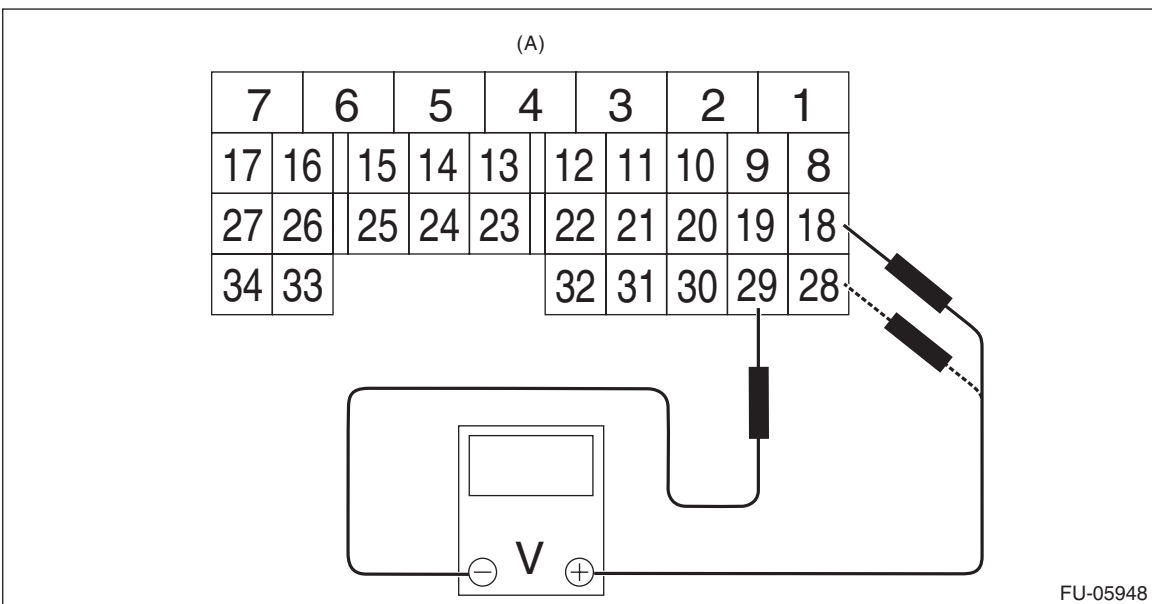

FU-05948

(A) To ECM connector

Throttle sensor	Accelerator pedal	Terminal No.	Standard
Main	Not depressed (Full closed)	18 (+) and 29 (-)	Approx. 0.6 V
	Depressed (Full opened)		Approx. 4.0 V
Sub	Not depressed (Full closed)	28 (+) and 29 (-)	Approx. 1.5 V
	Depressed (Full opened)		Approx. 4.2 V

- 4) After inspection, install the related parts in the reverse order of removal.

Throttle Body

FUEL INJECTION (FUEL SYSTEMS)

2. THROTTLE SENSOR (METHOD WITH SUBARU SELECT MONITOR)

- 1) Turn the ignition switch to ON. (engine OFF)
- 2) Read the throttle opening angle signal and voltage of throttle sensor using Subaru Select Monitor. <Ref. to EN(H4DO)(diag)-36, READ CURRENT DATA FOR ENGINE (NORMAL MODE), OPERATION, Subaru Select Monitor.>

Throttle sensor	Throttle opening angle signal	Standard
Main	0.0%	Approx. 0.6 V
	100.0%	Approx. 4.0 V
Sub	0.0%	Approx. 1.5 V
	100.0%	Approx. 4.2 V

3. OTHER INSPECTIONS

- 1) Check that the throttle body has no deformation, cracks or other damages.
- 2) Check that the preheater hose has no cracks, damage or loose part.