

Warning Light Illumination Pattern

VEHICLE DYNAMICS CONTROL (VDC) (DIAGNOSTICS)

10.Warning Light Illumination Pattern

A: INSPECTION

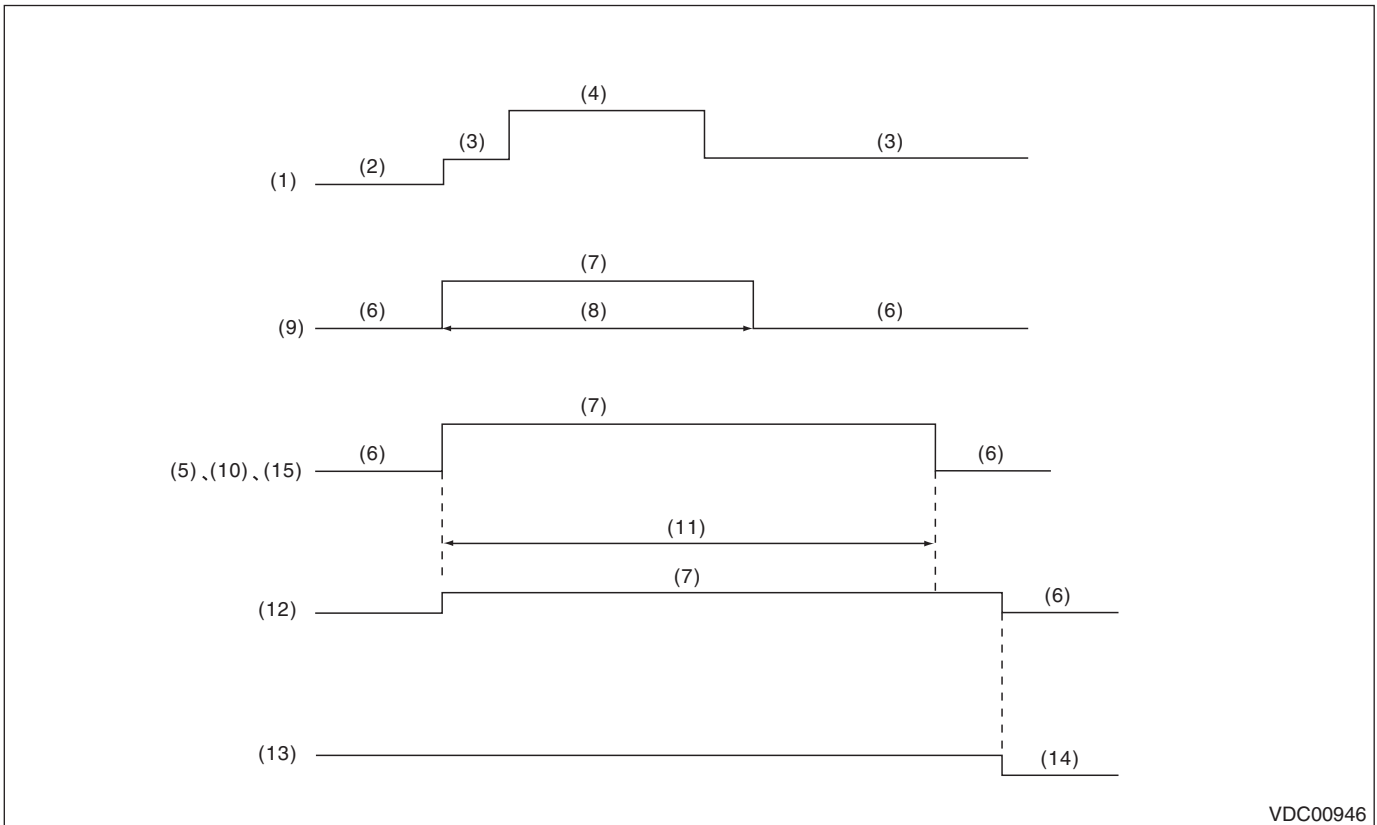

VDC00946

- | | | |
|-----------------------|--|--|
| (1) Ignition switch | (6) Light OFF | (11) 2 seconds or more |
| (2) OFF | (7) Light ON | (12) Brake warning light (EBD warning light) |
| (3) ON | (8) 2 seconds | (13) Parking brake |
| (4) Engine start | (9) VDC OFF indicator light | (14) Released |
| (5) ABS warning light | (10) VDC warning light & VDC indicator light | (15) Hill start assist warning light |

NOTE:

Hill start assist warning light always illuminates when the hill start assist is in the OFF mode.

Warning Light Illumination Pattern

VEHICLE DYNAMICS CONTROL (VDC) (DIAGNOSTICS)

1) When warning lights or indicator lights do not illuminate in accordance with this illumination pattern, there must be an electrical malfunction.

2) When the warning lights or indicator lights remain constantly OFF, check the combination meter circuit. <Ref. to VDC(diag)-27, EBD WARNING LIGHT, ABS WARNING, VDC OFF INDICATOR LIGHT, VDC WARNING LIGHT AND VDC INDICATOR LIGHT DO NOT COME ON, Warning Light Illumination Pattern.> <Ref. to VDC(diag)-28, HILL START ASSIST WARNING LIGHT DOES NOT COME ON, Warning Light Illumination Pattern.>

3) When the ABS warning light, VDC OFF indicator light, VDC warning light & VDC indicator light, and hill start assist warning light do not go off, check the combination meter circuit or CAN communication circuit. <Ref. to VDC(diag)-29, ABS WARNING LIGHT DOES NOT GO OFF, Warning Light Illumination Pattern.> <Ref. to VDC(diag)-31, VDC OFF INDICATOR LIGHT DOES NOT GO OFF, Warning Light Illumination Pattern.> <Ref. to VDC(diag)-30, VDC WARNING LIGHT AND VDC INDICATOR LIGHT DO NOT GO OFF, Warning Light Illumination Pattern.> <Ref. to VDC(diag)-33, HILL START ASSIST WARNING LIGHT DOES NOT GO OFF, Warning Light Illumination Pattern.>

NOTE:

- Even though the ABS warning light, and the VDC warning light & VDC indicator light do not go off in 2 seconds after illuminating, the ABS and VDC functions are normal if the warning lights go off while the vehicle is driven at approximately 38 km/h (23 MPH). However, while these lights are on, the functions with their warning lights illuminated do not operate.
- It may take several minutes before the VDC warning light & VDC indicator light goes off, if the vehicle is parked under low temperature for a specified time. This is not defective because it is resulted from low engine coolant temperature. Perform the Clear Memory Mode because DTC may be recorded at this time. <Ref. to VDC(diag)-24, Clear Memory Mode.>
- With the vehicle jack-up/lift-up or set on free rollers, when the wheels lock or spin after starting the engine, ABS warning light, and VDC warning light & VDC indicator light may illuminate because VDC-CM&H/U detects the abnormal conditions from ABS wheel speed sensor or longitudinal G sensor. In this case, this is not a malfunction. Perform the Clear Memory Mode. <Ref. to VDC(diag)-24, Clear Memory Mode.>

Warning Light Illumination Pattern

VEHICLE DYNAMICS CONTROL (VDC) (DIAGNOSTICS)

B: EBD WARNING LIGHT, ABS WARNING, VDC OFF INDICATOR LIGHT, VDC WARNING LIGHT AND VDC INDICATOR LIGHT DO NOT COME ON

DETECTING CONDITION:

Defective combination meter

TROUBLE SYMPTOM:

When the ignition switch is turned to ON (engine OFF), EBD warning light, ABS warning light, VDC OFF indicator light, and VDC warning light & VDC indicator light do not illuminate.

NOTE:

When pressing the VDC OFF switch for 10 seconds or more, the VDC OFF indicator light goes off and cannot operate any more. When turning the ignition switch from OFF to ON, the OFF operation enabled status is restored.

Step	Check	Yes	No
1 CHECK OTHER INDICATOR LIGHT. Turn the ignition switch to ON.	Does other indicator light illuminate soon after "ON"?	Go to step 2.	Check the combination meter. <Ref. to IDI-7, SELF-DIAGNOSIS DISPLAY MODE, OPERATION, Combination Meter System.>
2 CHECK VDCCM. When the engine does not start, display the current data of VDCCM using Subaru Select Monitor.	Immediately after the ignition switch is turned to ON, is the «EBD Warning Light» ON?	Go to step 3.	Replace the VDCCM only. <Ref. to VDC-16, REPLACEMENT, VDC Control Module and Hydraulic Control Unit (VDCCM&H/U).>
3 CHECK VDCCM. When the engine does not start, display the current data of VDCCM using Subaru Select Monitor.	Immediately after the ignition switch is turned to ON, is the «ABS Warning Lamp» ON?	Go to step 4.	Replace the VDCCM only. <Ref. to VDC-16, REPLACEMENT, VDC Control Module and Hydraulic Control Unit (VDCCM&H/U).>
4 CHECK VDCCM. When the engine does not start, display the current data of VDCCM using Subaru Select Monitor.	Immediately after the ignition switch is turned to ON, is the «VDC Warning Lamp» ON?	Check the combination meter. <Ref. to IDI-7, SELF-DIAGNOSIS DISPLAY MODE, OPERATION, Combination Meter System.>	Replace the VDCCM only. <Ref. to VDC-16, REPLACEMENT, VDC Control Module and Hydraulic Control Unit (VDCCM&H/U).>

Warning Light Illumination Pattern

VEHICLE DYNAMICS CONTROL (VDC) (DIAGNOSTICS)

C: HILL START ASSIST WARNING LIGHT DOES NOT COME ON

DETECTING CONDITION:

Defective combination meter

TROUBLE SYMPTOM:

When the ignition switch is turned to ON (engine OFF), hill start assist warning light does not illuminate.

Step	Check	Yes	No
1 CHECK OTHER INDICATOR LIGHT. Turn the ignition switch to ON. (engine OFF)	Do other indicator lights illuminate?	Go to step 2.	Check the combination meter. <Ref. to IDI-7, SELF-DIAGNOSIS DISPLAY MODE, OPERATION, Combination Meter System.>
2 READ DTC. Read the DTC. <Ref. to VDC(diag)-22, Read Diagnostic Trouble Code (DTC).>	Is DTC displayed?	Perform the diagnosis according to DTC. <Ref. to VDC(diag)-37, List of Diagnostic Trouble Code (DTC).>	Go to step 3.
3 CHECK LAN SYSTEM. Perform the diagnosis for LAN system. <Ref. to LAN(diag)-2, Basic Diagnostic Procedure.>	Is there any fault in LAN system?	Perform the diagnosis according to DTC for LAN system. <Ref. to LAN(diag)-50, List of Diagnostic Trouble Code (DTC).>	Go to step 4.
4 CHECK COMBINATION METER. Check the combination meter. <Ref. to IDI-7, SELF-DIAGNOSIS DISPLAY MODE, OPERATION, Combination Meter System.>	Is combination meter OK?	Replace the VDCCM only. <Ref. to VDC-16, REPLACEMENT, VDC Control Module and Hydraulic Control Unit (VDCCM&H/U).>	Replace the combination meter. <Ref. to IDI-17, Combination Meter.>

Warning Light Illumination Pattern

VEHICLE DYNAMICS CONTROL (VDC) (DIAGNOSTICS)

D: ABS WARNING LIGHT DOES NOT GO OFF

DETECTING CONDITION:

- Defective combination meter
- Defective CAN communication

TROUBLE SYMPTOM:

When starting the engine, the ABS warning light is kept on.

	Step	Check	Yes	No
1	READ DTC. Read the DTC. <Ref. to VDC(diag)-22, Read Diagnostic Trouble Code (DTC).>	Is DTC displayed?	Perform the diagnosis according to DTC. <Ref. to VDC(diag)-37, List of Diagnostic Trouble Code (DTC).>	Go to step 2.
2	CHECK VDCCM. Display the current data of VDCCM using Subaru Select Monitor.	Is the «ABS Warning Lamp» ON?	Go to step 3.	Go to step 4.
3	READ DTC. Read the DTC after driving the vehicle at 40 km/h (25 MPH) or more.	Is DTC displayed?	Perform the diagnosis according to DTC. <Ref. to VDC(diag)-37, List of Diagnostic Trouble Code (DTC).>	Go to step 4.
4	CHECK LAN SYSTEM. Perform the diagnosis for LAN system. <Ref. to LAN(diag)-2, Basic Diagnostic Procedure.>	Is there any fault in LAN system?	Perform the diagnosis according to DTC for LAN system. <Ref. to LAN(diag)-50, List of Diagnostic Trouble Code (DTC).>	Go to step 5.
5	CHECK COMBINATION METER. Check the combination meter. <Ref. to IDI-7, SELF-DIAGNOSIS DISPLAY MODE, OPERATION, Combination Meter System.>	Is combination meter OK?	Replace the VDCCM only. <Ref. to VDC-16, REPLACEMENT, VDC Control Module and Hydraulic Control Unit (VDCCM&H/U).>	Replace the combination meter. <Ref. to IDI-17, Combination Meter.>

Warning Light Illumination Pattern

VEHICLE DYNAMICS CONTROL (VDC) (DIAGNOSTICS)

E: VDC WARNING LIGHT AND VDC INDICATOR LIGHT DO NOT GO OFF

DETECTING CONDITION:

- Defective combination meter
- Defective engine
- Defective CAN communication

TROUBLE SYMPTOM:

When starting the engine, the VDC warning light & VDC indicator light remains lit.

Step	Check	Yes	No
1 READ DTC. Read the DTC. <Ref. to VDC(diag)-22, Read Diagnostic Trouble Code (DTC).>	Is DTC displayed?	Perform the diagnosis according to DTC. <Ref. to VDC(diag)-37, List of Diagnostic Trouble Code (DTC).>	Go to step 2.
2 CHECK VDCCM. Display the current data of VDCCM using Subaru Select Monitor.	Is the «VDC Warning Lamp» ON?	Go to step 3.	Go to step 4.
3 READ DTC. Read the DTC after driving the vehicle at 40 km/h (25 MPH) or more.	Is DTC displayed?	Perform the diagnosis according to DTC. <Ref. to VDC(diag)-37, List of Diagnostic Trouble Code (DTC).>	Go to step 4.
4 CHECK LAN SYSTEM. Perform the diagnosis for LAN system. <Ref. to LAN(diag)-2, Basic Diagnostic Procedure.>	Is there any fault in LAN system?	Perform the diagnosis according to DTC for LAN system. <Ref. to LAN(diag)-50, List of Diagnostic Trouble Code (DTC).>	Go to step 5.
5 CHECK COMBINATION METER. Check the combination meter. <Ref. to IDI-7, SELF-DIAGNOSIS DISPLAY MODE, OPERATION, Combination Meter System.>	Is combination meter OK?	Replace the VDCCM only. <Ref. to VDC-16, REPLACEMENT, VDC Control Module and Hydraulic Control Unit (VDCCM&H/U).>	Replace the combination meter. <Ref. to IDI-17, Combination Meter.>

Warning Light Illumination Pattern

VEHICLE DYNAMICS CONTROL (VDC) (DIAGNOSTICS)

F: VDC OFF INDICATOR LIGHT DOES NOT GO OFF

DETECTING CONDITION:

- Defective combination meter
- Defective CAN communication
- VDC OFF switch is shorted.

TROUBLE SYMPTOM:

When starting the engine, VDC OFF indicator light is kept ON.

WIRING DIAGRAM:

Vehicle Dynamics Control System <Ref. to WI-152, Vehicle Dynamics Control System.>

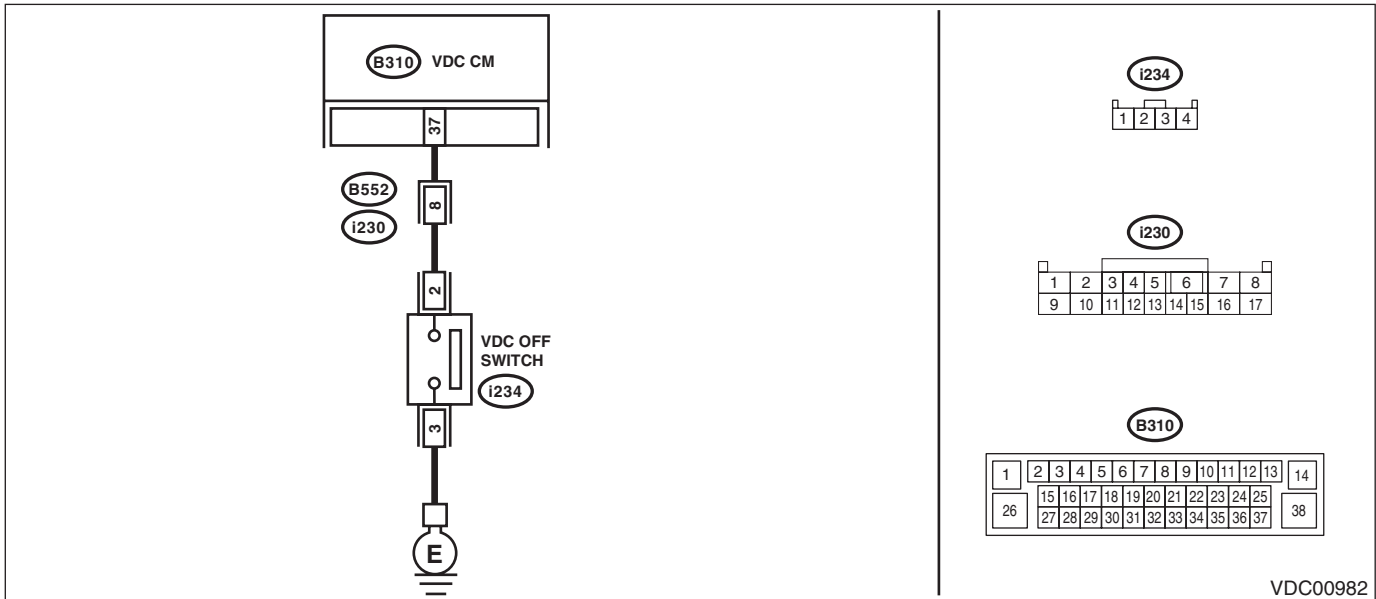

VDC00982

Step	Check	Yes	No
1 READ DTC. Read the DTC. <Ref. to VDC(diag)-22, Read Diagnostic Trouble Code (DTC).>	Is DTC displayed?	Perform the diagnosis according to DTC. <Ref. to VDC(diag)-37, List of Diagnostic Trouble Code (DTC).>	Go to step 2.
2 CHECK VDC OFF SWITCH. Remove and check VDC OFF switch. <Ref. to VDC-42, VDC OFF Switch.>	Is the VDC OFF switch normal?	Go to step 3.	Replace the VDC OFF switch.
3 CHECK VDC OFF SWITCH CIRCUIT. 1) Disconnect the connector from the VDCCM&H/U. 2) Measure the resistance between VDCCM&H/U connector and chassis ground. Connector & terminal (B310) No. 37 — Chassis ground:	Is the resistance less than 10 Ω?	Check the VDC OFF switch circuit.	Go to step 4.
4 CHECK LAN SYSTEM. Perform the diagnosis for LAN system. <Ref. to LAN(diag)-2, Basic Diagnostic Procedure.>	Is there any fault in LAN system?	Perform the diagnosis according to DTC for LAN system. <Ref. to LAN(diag)-50, List of Diagnostic Trouble Code (DTC).>	Go to step 5.

Warning Light Illumination Pattern

VEHICLE DYNAMICS CONTROL (VDC) (DIAGNOSTICS)

Step	Check	Yes	No
5 CHECK COMBINATION METER. Check the combination meter. <Ref. to IDI-7, SELF-DIAGNOSIS DISPLAY MODE, OPERATION, Combination Meter System.>	Is combination meter OK?	Replace the VDCCM only. <Ref. to VDC-16, REPLACEMENT, VDC Control Module and Hydraulic Control Unit (VDCCM&H/U).>	Replace the combination meter. <Ref. to IDI-17, Combination Meter.>

Warning Light Illumination Pattern

VEHICLE DYNAMICS CONTROL (VDC) (DIAGNOSTICS)

G: HILL START ASSIST WARNING LIGHT DOES NOT GO OFF

DETECTING CONDITION:

- Defective combination meter
- Defective CAN communication

TROUBLE SYMPTOM:

When starting the engine, the hill start assist warning light continues to illuminate.

Step	Check	Yes	No
1 READ DTC. Read the DTC. <Ref. to VDC(diag)-22, Read Diagnostic Trouble Code (DTC).>	Is DTC displayed?	Perform the diagnosis according to DTC. <Ref. to VDC(diag)-37, List of Diagnostic Trouble Code (DTC).>	Go to step 2.
2 CHECK LAN SYSTEM. Perform the diagnosis for LAN system. <Ref. to LAN(diag)-2, Basic Diagnostic Procedure.>	Is there any fault in LAN system?	Perform the diagnosis according to DTC for LAN system. <Ref. to LAN(diag)-50, List of Diagnostic Trouble Code (DTC).>	Go to step 3.
3 CHECK COMBINATION METER. Check the combination meter. <Ref. to IDI-7, SELF-DIAGNOSIS DISPLAY MODE, OPERATION, Combination Meter System.>	Is combination meter OK?	Replace the VDCCM only. <Ref. to VDC-16, REPLACEMENT, VDC Control Module and Hydraulic Control Unit (VDCCM&H/U).>	Replace the combination meter. <Ref. to IDI-17, Combination Meter.>

Warning Light Illumination Pattern

VEHICLE DYNAMICS CONTROL (VDC) (DIAGNOSTICS)

H: BRAKE WARNING LIGHT DOES NOT GO OFF

DETECTING CONDITION:

- Brake warning light circuit is shorted.
- Defective sensor/connector
- Defective CAN communication

TROUBLE SYMPTOM:

After starting the engine, the brake warning light remains lit though the parking lever is released.

Warning Light Illumination Pattern

VEHICLE DYNAMICS CONTROL (VDC) (DIAGNOSTICS)

Step	Check	Yes	No
1 CHECK INSTALLATION OF VDCCM&H/U CONNECTOR. 1) Turn the ignition switch to OFF. 2) Check that the VDCCM&H/U connector is inserted until it is locked by clamp.	Is the connector firmly inserted?	Go to step 2.	Insert the VDCCM&H/U connector until it is locked by clamp.
2 READ DTC. Read the DTC. <Ref. to VDC(diag)-22, Read Diagnostic Trouble Code (DTC).>	Is DTC displayed?	Perform the diagnosis according to DTC. <Ref. to VDC(diag)-37, List of Diagnostic Trouble Code (DTC).>	Go to step 3.
3 CHECK BRAKE FLUID AMOUNT. Check the amount of brake fluid in the reservoir tank of master cylinder.	Does the level of the brake fluid amount fall between the lines of "MAX" and "MIN"?	Go to step 4.	Replenish brake fluid to the specified value.
4 CHECK BRAKE FLUID LEVEL SWITCH. 1) Turn the ignition switch to OFF. 2) Disconnect the level switch connector (B16) from master cylinder. 3) Measure the resistance of master cylinder terminals. Terminals No. 1 — No. 2:	Is the resistance 1 MΩ or more?	Go to step 5.	Replace the master cylinder. <Ref. to BR-44, Master Cylinder.>
5 CHECK GROUND SHORT OF HARNESS. 1) Disconnect the connector (i10) from combination meter. 2) Measure the resistance between combination meter connector and chassis ground. Connector & terminal (i10) No. 23 — Chassis ground:	Is the resistance 1 MΩ or more?	Go to step 6.	Repair the harness between combination meter and brake fluid level switch.
6 CHECK PARKING BRAKE SWITCH. 1) Disconnect the connector (R4) from parking brake switch. 2) Release the parking brake. 3) Measure the resistance between parking brake switch terminal and chassis ground.	Is the resistance 1 MΩ or more?	Go to step 7.	Replace the parking brake switch.
7 CHECK GROUND SHORT OF HARNESS. 1) Disconnect the connector (i84) from body integrated unit. 2) Measure the resistance between body integrated unit connector and chassis ground. Connector & terminal (i84) No. 32 — Chassis ground:	Is the resistance 1 MΩ or more?	Go to step 8.	Repair the harness between body integrated unit and parking brake switch.
8 CHECK POOR CONTACT OF CONNECTOR. Check for poor contact of all connectors.	Is there poor contact?	Repair the connector.	Go to step 9.
9 CHECK LAN SYSTEM. Perform the diagnosis for LAN system. <Ref. to LAN(diag)-2, Basic Diagnostic Procedure.>	Is there any fault in LAN system?	Perform the diagnosis according to DTC for LAN system. <Ref. to LAN(diag)-50, List of Diagnostic Trouble Code (DTC).>	Go to step 10.
10 CHECK COMBINATION METER. Check the combination meter. <Ref. to IDI-7, SELF-DIAGNOSIS DISPLAY MODE, OPERATION, Combination Meter System.>	Is combination meter OK?	Replace the VDCCM only. <Ref. to VDC-16, REPLACEMENT, VDC Control Module and Hydraulic Control Unit (VDCCM&H/U).>	Replace the combination meter. <Ref. to IDI-17, Combination Meter.>