

6. Rear Disc Rotor

A: REMOVAL

- 1) Lift up the vehicle, and then remove the rear wheels.
- 2) Release the lever assembly - hand brake.
- 3) Remove the caliper body assembly from the housing assembly - rear axle.
 - (1) Remove the bolt from the brake hose bracket.
 - (2) Remove the mounting bolt, and remove the caliper body assembly.

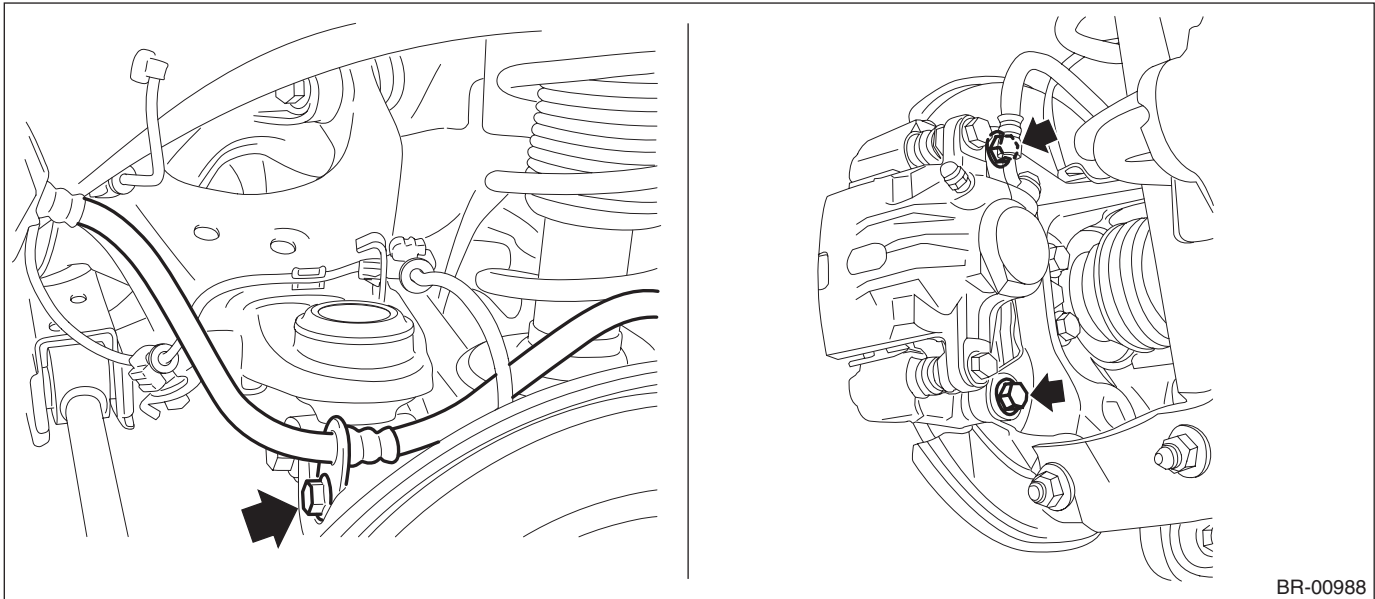

- (3) Prepare wiring harnesses etc. to be discarded, and suspend the caliper body assembly from the strut assembly.

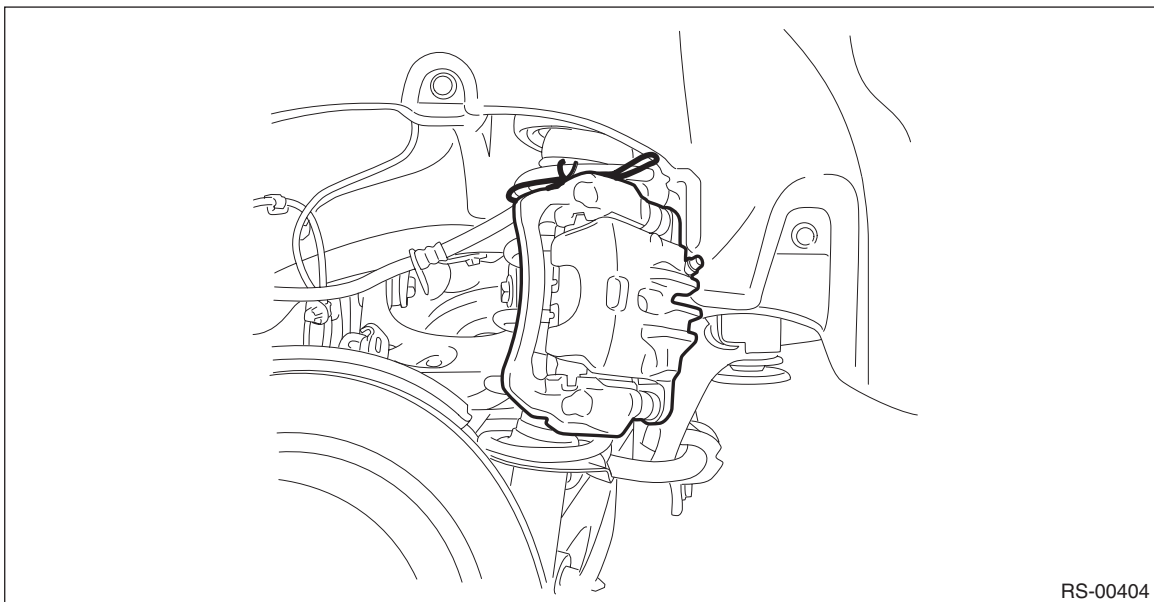

4) Remove the rear disc rotor.

NOTE:

If it is difficult to remove the disc rotor, perform the following two methods in order.

1. Remove the adjusting hole cover (A), insert the flat tip screwdriver, and rotate the adjuster assembly - rear brake until the brake shoe moves far enough to remove the disc rotor.

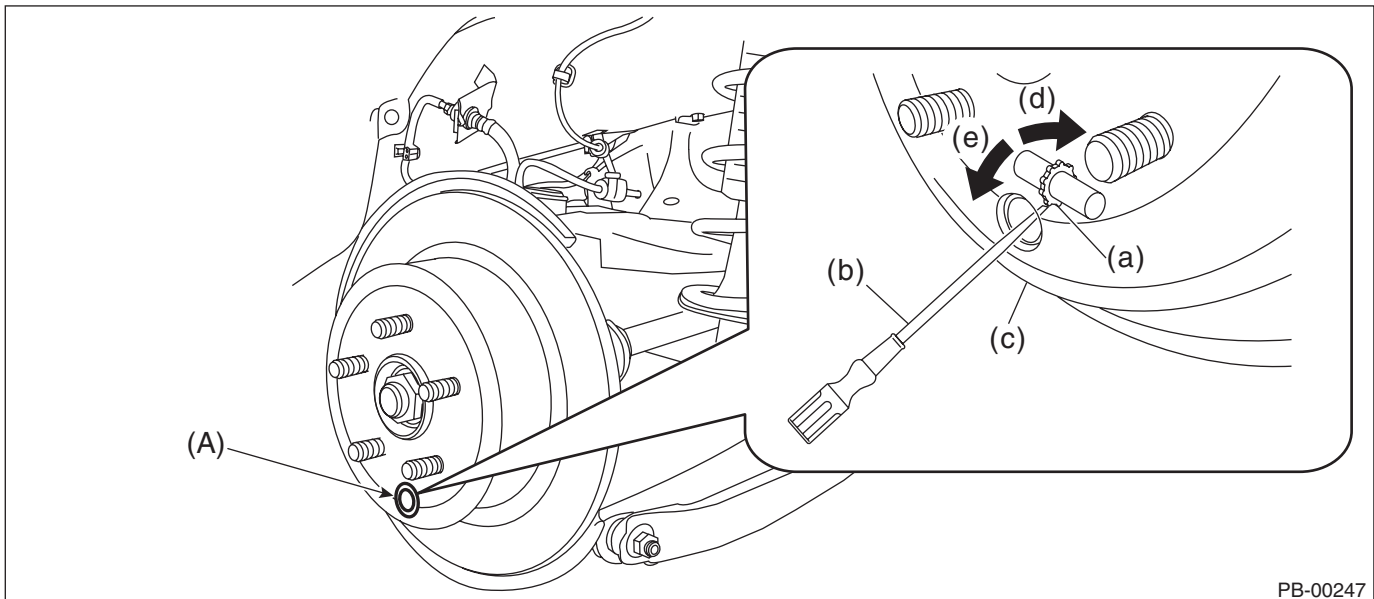

PB-00247

- | | | |
|--------------------------------|---|--|
| (a) Adjuster ASSY - rear brake | (c) Disc rotor | (e) Shorten the adjuster ASSY - rear brake |
| (b) Flat tip screwdriver | (d) Extend the adjuster ASSY - rear brake | |

2. When the disc rotor is difficult to be removed from the hub unit COMPL - rear axle, screw in 8 mm (0.31 in) bolt to the threaded part of the disc rotor (A), and remove the disc rotor.

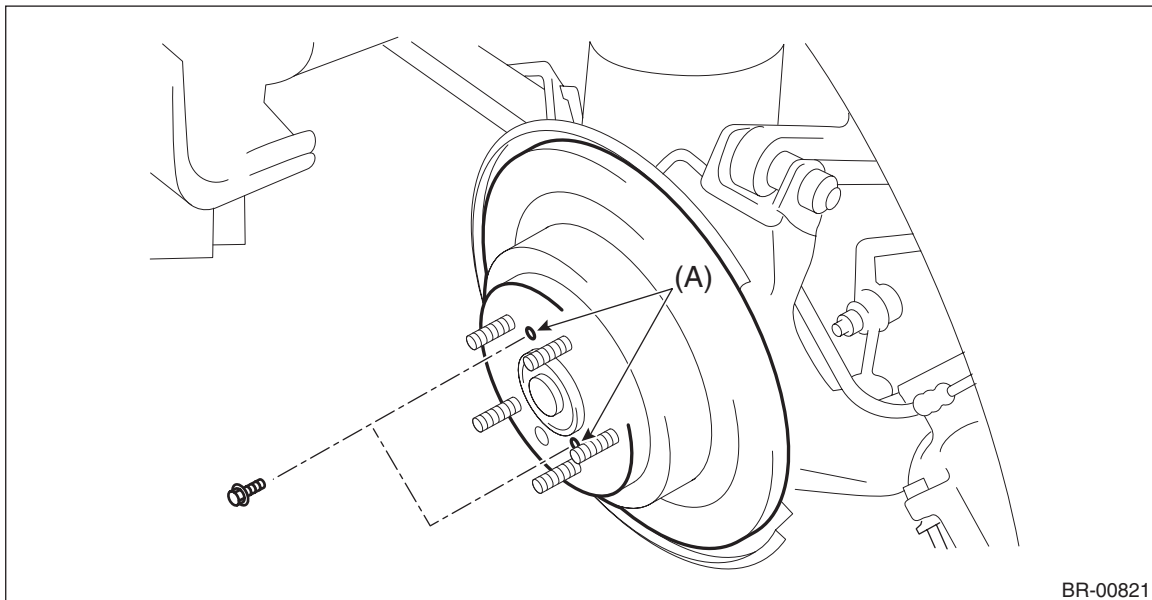

BR-00821

Rear Disc Rotor

BRAKE

B: INSTALLATION

NOTE:

Before installation, remove mud and foreign matter from the caliper body assembly.

- 1) Before installation, check the rear disc rotor. <Ref. to BR-34, INSPECTION, Rear Disc Rotor.>
- 2) Install each part in the reverse order of removal.
- 3) Adjust the parking brake. <Ref. to PB-22, ADJUSTMENT, Parking Brake Assembly (Rear Disc Brake).>

Tightening torque:

Brake hose bracket: 33 N·m (3.36 kgf-m, 24.3 ft-lb)

Mounting bolt: 66 N·m (6.73 kgf-m, 48.7 ft-lb)

Rear wheel: 120 N·m (12.24 kgf-m, 88.5 ft-lb)

C: INSPECTION

1. DISC ROTOR RUNOUT CHECK

- 1) Check the hub unit COMPL - rear axle for free play and runout before the inspection of disc rotor runout limit. <Ref. to DS-56, INSPECTION, Rear Hub Unit Bearing.>
- 2) Secure the disc rotor by tightening the five wheel nuts.
- 3) Set a dial gauge 10 mm (0.39 in) inward from the disc rotor outer circumference, and check the disc rotor runout while rotating the disc rotor.

Disc rotor runout limit:

0.05 mm (0.0020 in)

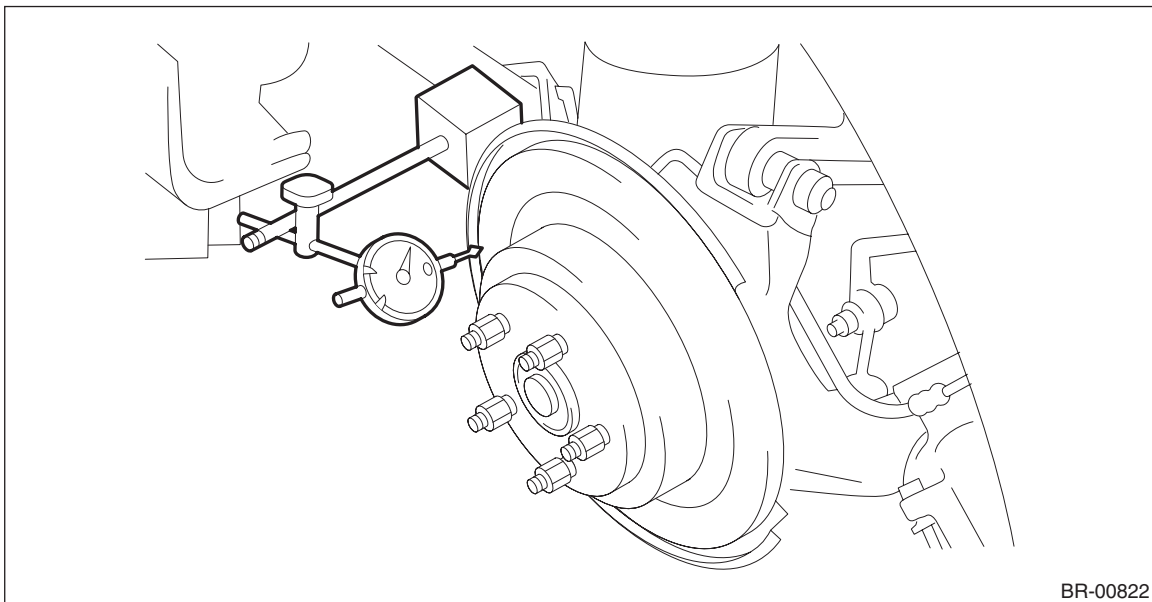

- 4) If the runout limit is exceeded in the inspection, replace the disc rotor.

2. DISC ROTOR THICKNESS CHECK

1) Set a micrometer 10 mm (0.39 in) inward from the disc rotor outer perimeter, and then measure the disc rotor thickness (A).

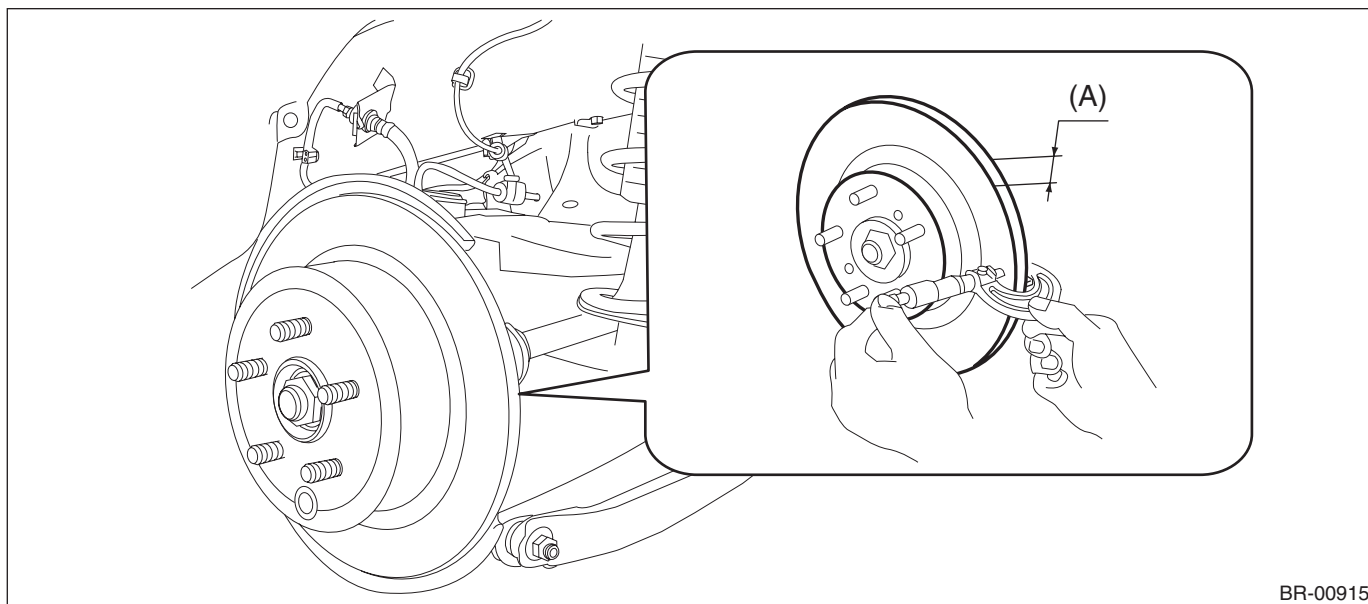

BR-00915

	Type of disc rotor	Standard	Wear limit	Disc rotor outer diameter
Disc rotor thickness (A)	Solid disc	10 mm (0.39 in)	8.5 mm (0.33 in)	274 mm (10.79 in)

2) If the wear limit is exceeded in the inspection, replace the disc rotor.