

9. Brake Booster

A: REMOVAL

CAUTION:

Do not allow brake fluid to come in contact with the painted surface of the vehicle body. If it does, wash off with water and wipe away completely.

- 1) Disconnect the ground cable from battery and wait for at least 60 seconds before starting work.
- 2) Drain brake fluid from the reservoir tank completely.
- 3) Disconnect the air conditioner pipe. <Ref. to AC-71, REMOVAL, Hose and Pipe.>
- 4) Remove the power steering control module. <Ref. to PS-42, REMOVAL, Power Steering Control Module.>
- 5) Remove the master cylinder assembly.
 - (1) Disconnect the fluid level gauge connector (a).
 - (2) Disconnect the clutch hose (b). (MT model)
 - (3) Disconnect the brake pipe (c).
 - (4) Remove the nut (d), and slowly remove the master cylinder assembly from the vacuum booster assembly.

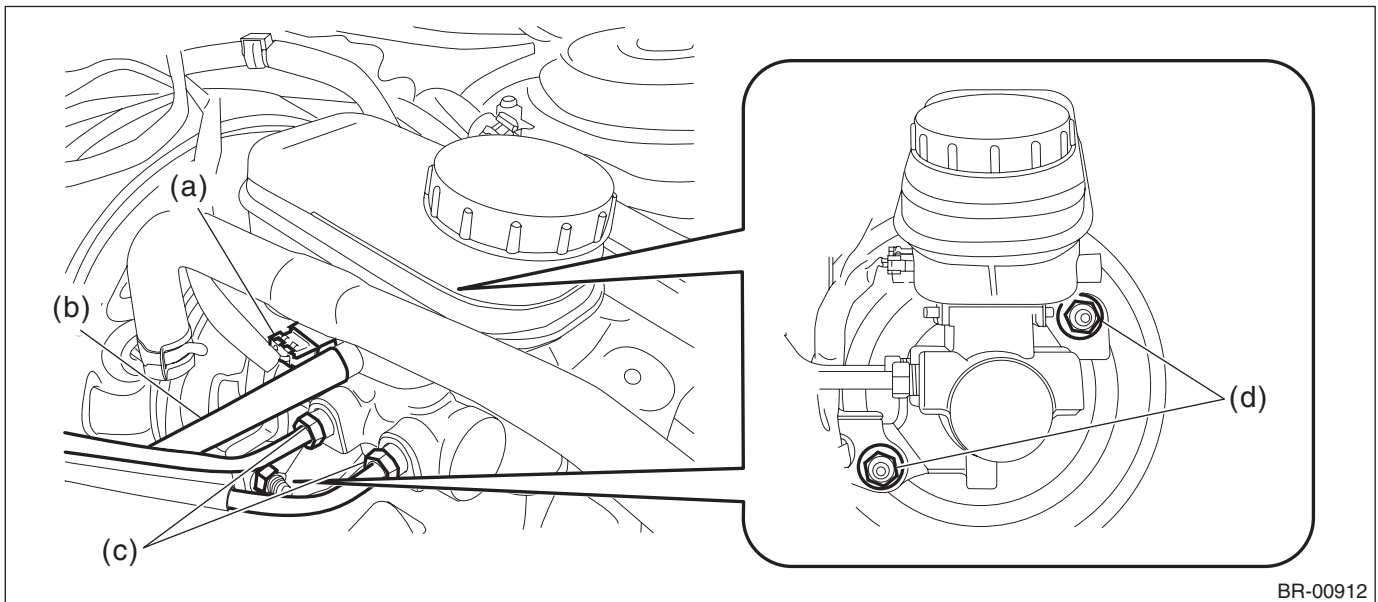

BR-00912

6) Remove the clamp and remove the vacuum hose.

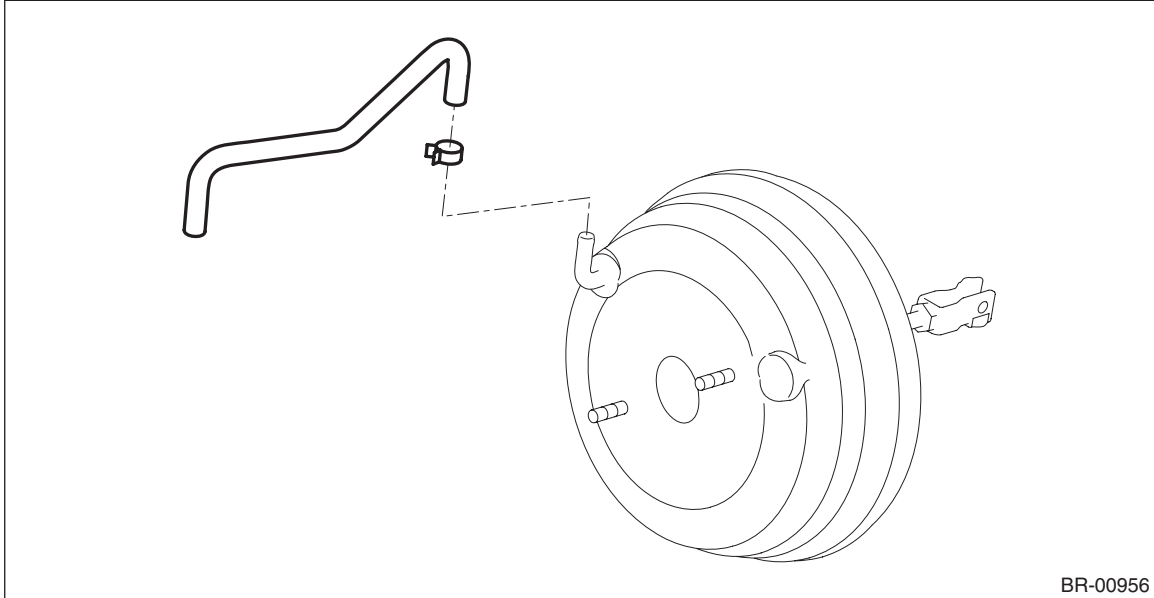

7) Remove the brake pipe assembly (a).

(1) Disconnect the starter connector (b) and harness clip (c).

(2) Remove the brake pipe assembly (a) from the pipe clip (d).

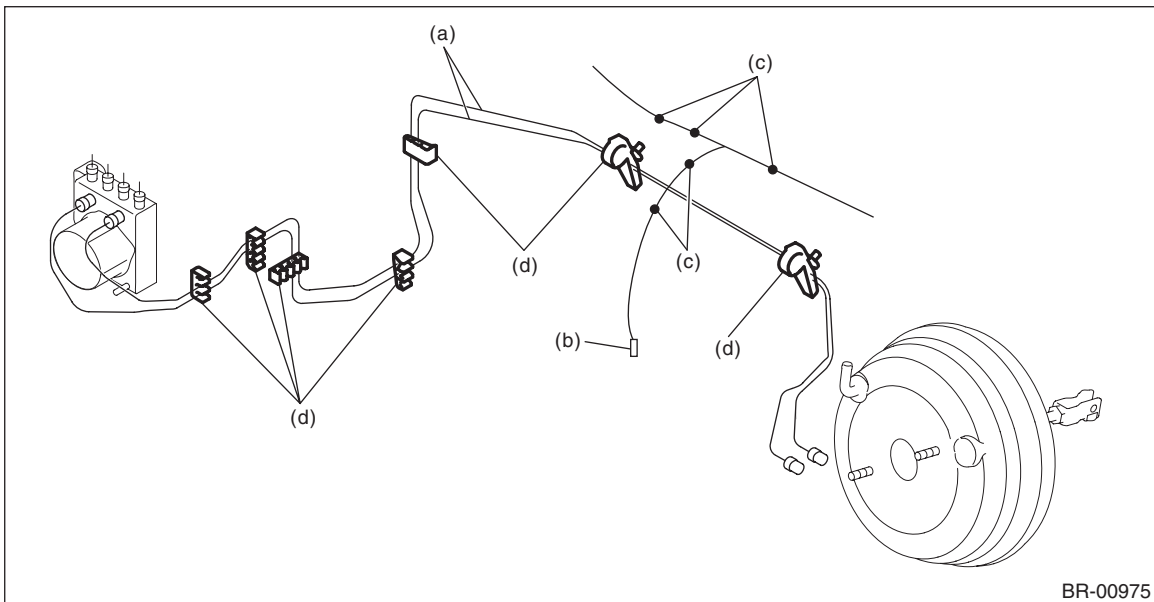

Brake Booster

BRAKE

8) Remove the cover assembly - instrument panel LWR driver.

CAUTION:

When removing the cover assembly - instrument panel LWR driver, be sure to pull it toward you. If attempting to remove by turning it upward, the claws may be damaged.

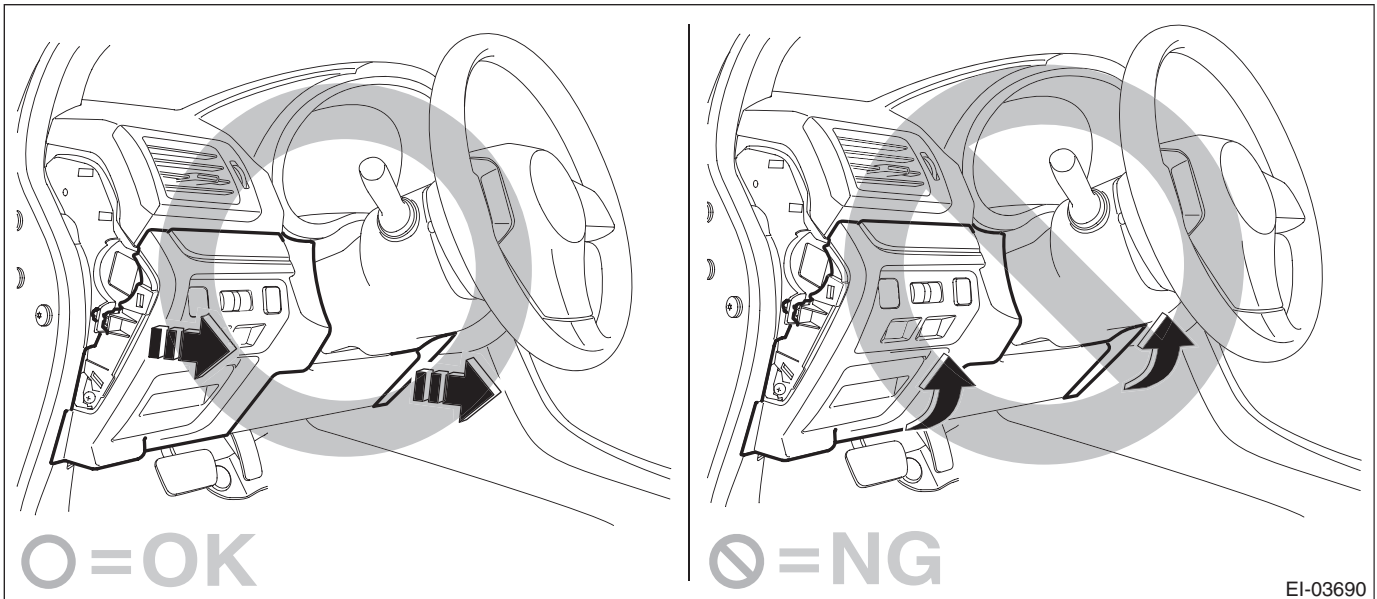

(1) Remove the clips, and remove the cover - instrument panel side LH.

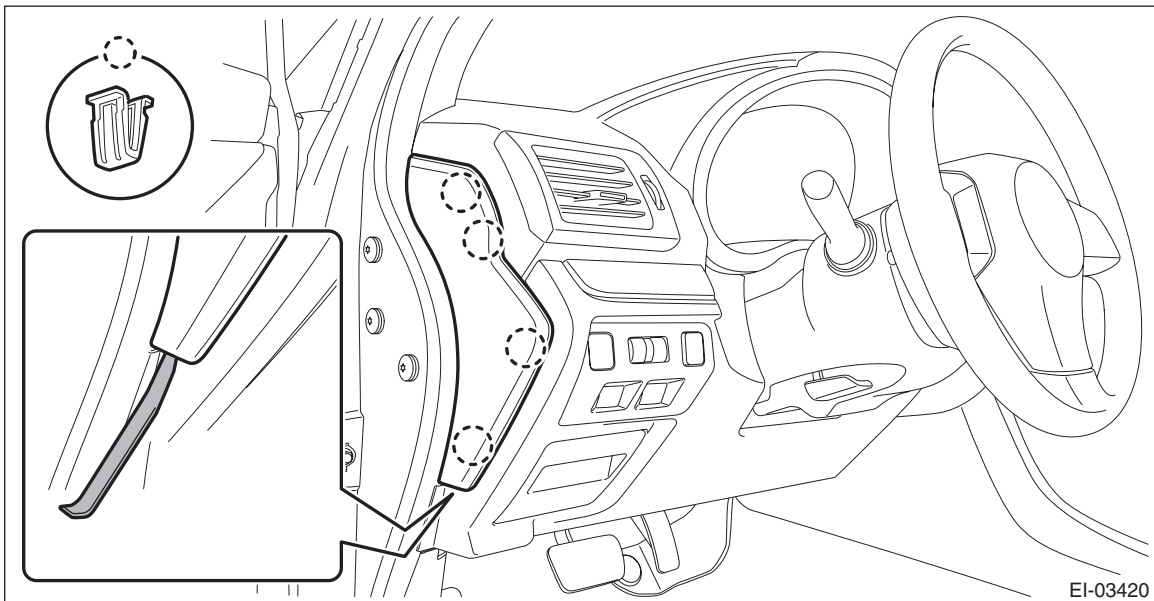

NOTE:

Using a plastic remover, open the cover - instrument panel side LH.

(2) Remove the screws and release the clips and claws.

(3) Disconnect the harness connectors, and remove the cover assembly - instrument panel LWR driver INN and OUT.

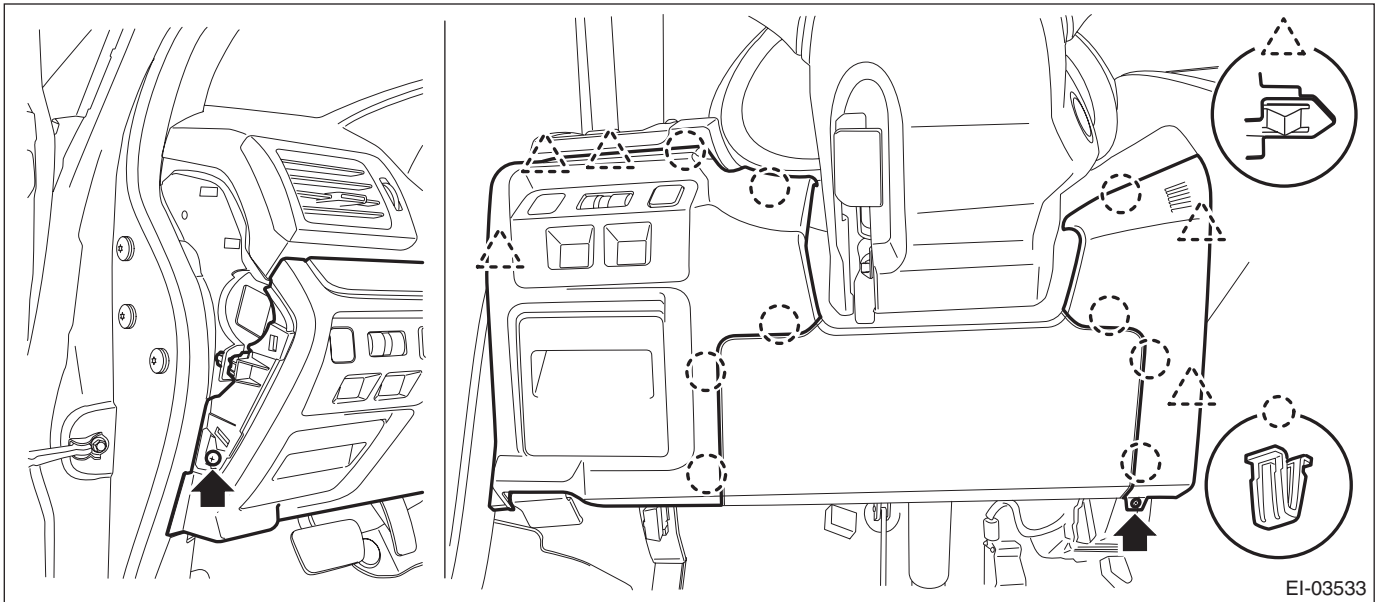

9) Remove the nuts to remove the knee airbag module and disconnect the harness connector. <Ref. to AB-33, KNEE AIRBAG MODULE, PROCEDURE, Airbag Connector.>

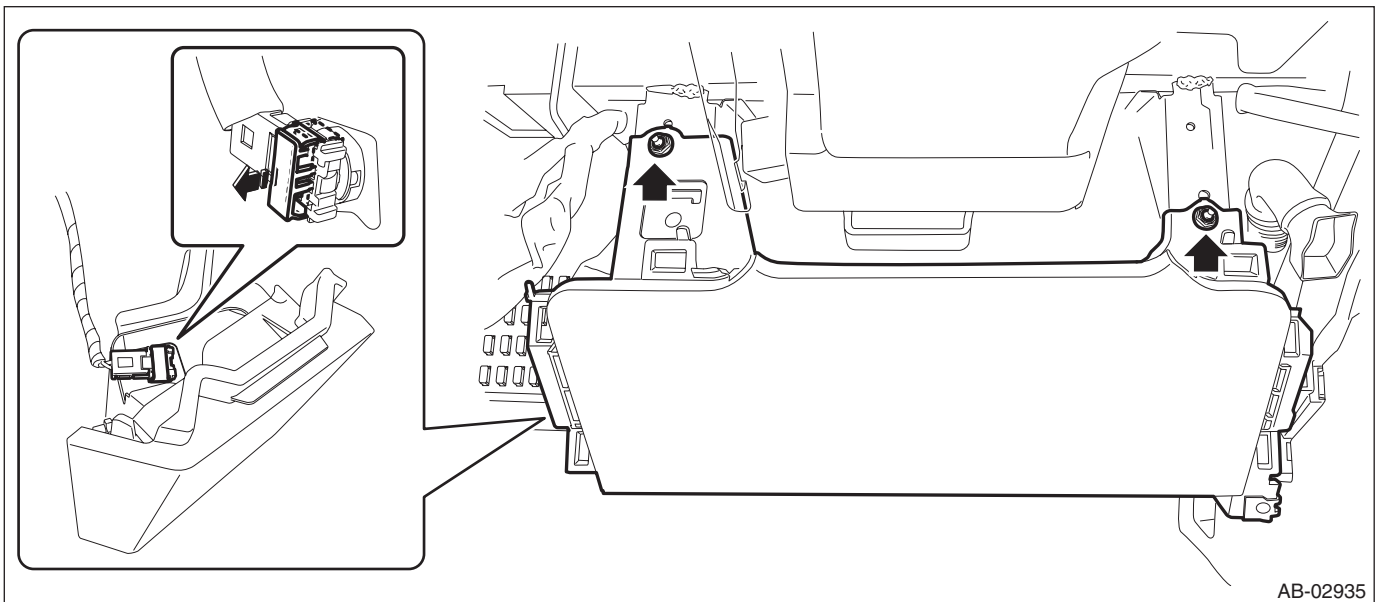

Brake Booster

BRAKE

10) Remove the snap pin (a) and clevis pin (b), and remove the operating rod from the brake pedal.

CAUTION:

- Be careful not to apply excessive force to the operating rod when handling the operating rod. The angle may change by $\pm 3^\circ$, and it may result in damage to power piston cylinder.
- Do not change the push rod length.

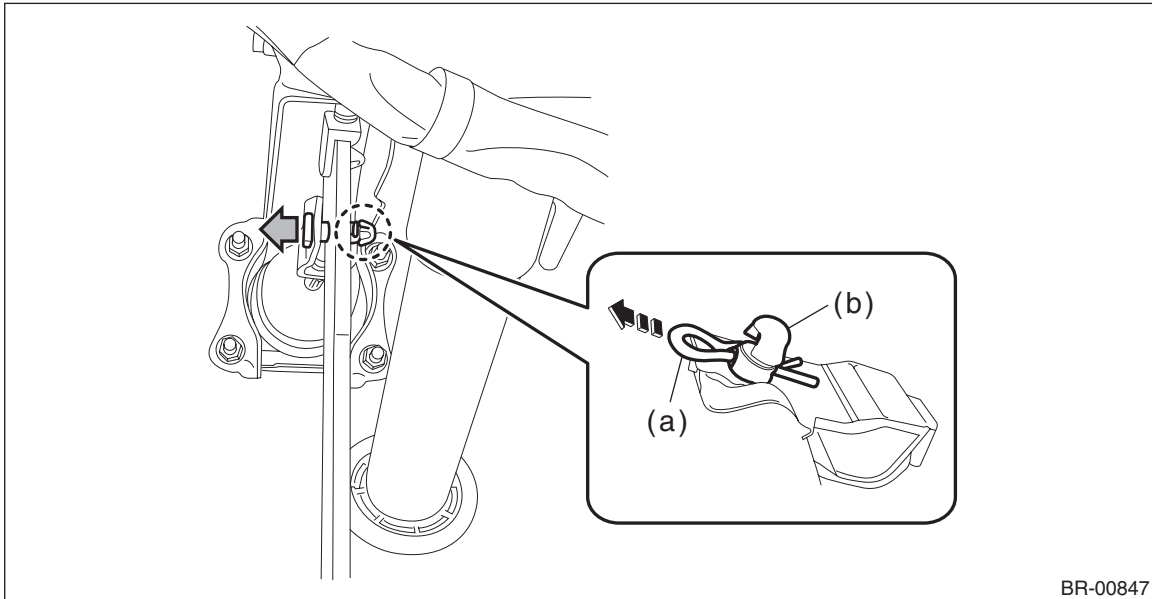

11) Remove the vacuum booster assembly.

CAUTION:

- Do not disassemble the vacuum booster assembly.
- Make sure that the booster shell and vacuum pipe are not subject to strong impacts.
- Be careful not to drop the vacuum booster assembly. If the vacuum booster assembly is dropped accidentally, replace it.
- Be careful when placing the vacuum booster assembly on floor.
- If external force (a) is applied from above when the vacuum booster assembly is placed in this position, the resin portion as indicated by "P" may become damaged.

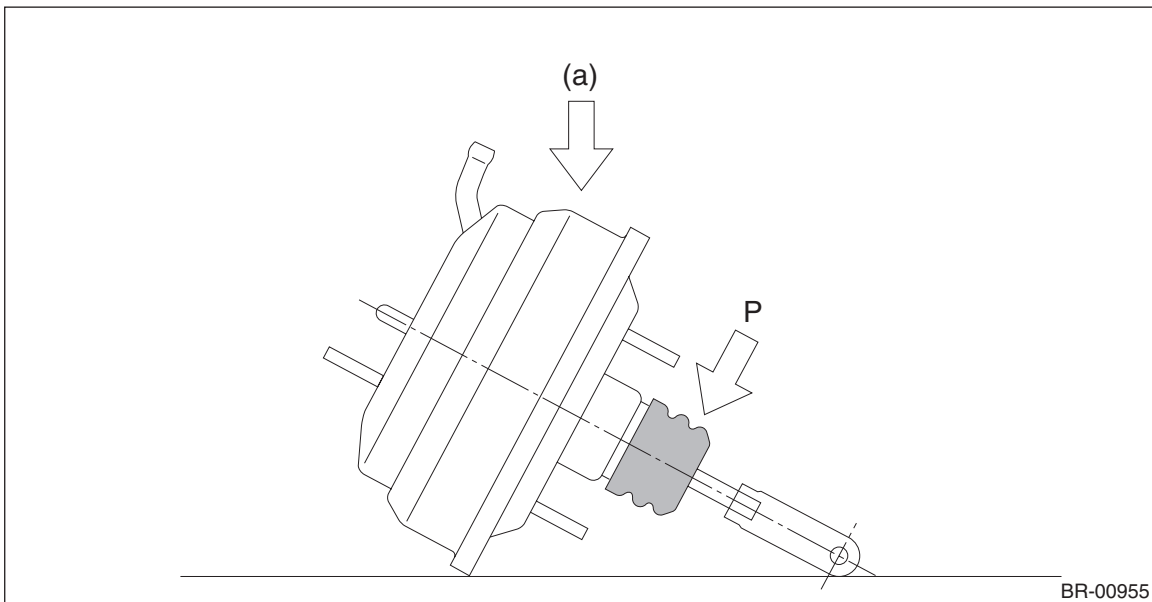

(1) Remove the nuts, and then remove the vacuum booster assembly.

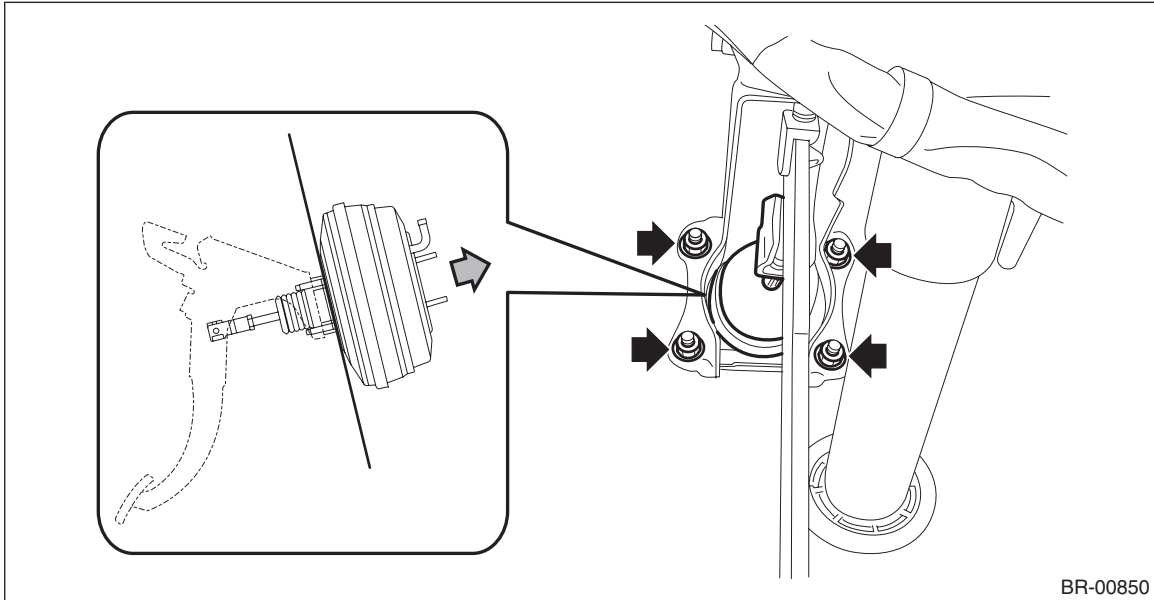

B: INSTALLATION

1) Check and adjust the operating rod of the vacuum booster assembly.

- (1) Measure the length between the vacuum booster assembly mounting surface and clevis pin hole.
- (2) If it is not within the specification, loosen the lock nut, rotate the vacuum booster assembly operating rod to adjust the rod length.

Specification L:
136.3 mm (5.37 in)

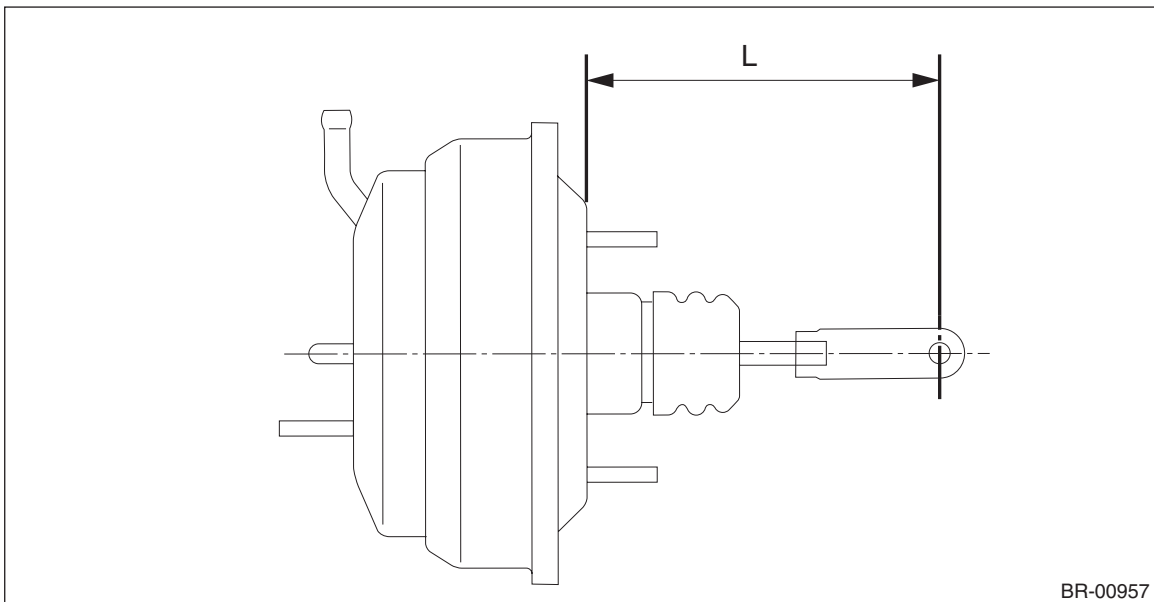

Brake Booster

BRAKE

2) Install each part in the reverse order of removal.

CAUTION:

- Apply grease to the snap pin to prevent the operating rod from wear.
- Replace the clevis pin with new parts, and apply thin coat of NIGTIGHT LYW No. 2 grease to the clevis pin.
- When installing the master cylinder assembly, replace the seal sub assembly with a new part, and install it to the vacuum booster assembly.

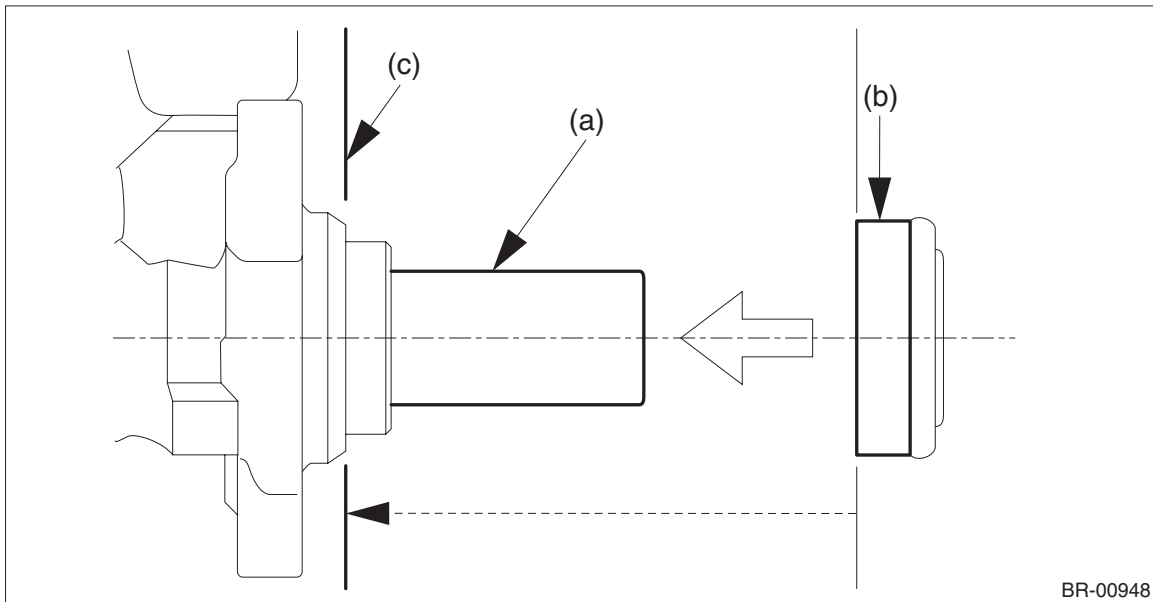

(a) Primary piston

(b) Seal sub ASSY

(c) Install the seal sub assembly to this surface.

Tightening torque:

Vacuum booster assembly: 18 N·m (1.84 kgf-m, 13.3 ft-lb)

Master cylinder assembly: 13 N·m (1.33 kgf-m, 9.6 ft-lb)

Brake pipe flare nut: 19 N·m (1.94 kgf-m, 14.0 ft-lb)

Operating lock nut: 22 N·m (2.24 kgf-m, 16.2 ft-lb)

Knee airbag module: 7.5 N·m (0.76 kgf-m, 5.5 ft-lb)

3) Install the air conditioner pipe. <Ref. to AC-12, AIR CONDITIONING UNIT, COMPONENT, General Description.>

4) Bleed air from the brake system. <Ref. to BR-59, PROCEDURE, Air Bleeding.>

5) Perform a road test to make sure the brakes do not drag.

C: INSPECTION

1. OPERATION CHECK WHEN NOT USING MEASURING DEVICES

CAUTION:

When checking operation, be sure to apply the parking brake securely.

When an operation check is performed with no measuring devices, a faulty part cannot be identified correctly. But it is possible to identify the outline of the defect by performing the check according to the following procedures.

• **Air tightness check**

- 1) Start the engine, and idle it for 1 to 2 minutes, then turn it OFF.
- 2) Depress the brake pedal several times applying the normal pedal force.

NOTE:

The pedal stroke should be the longest at the 1st depression, and it should become shorter at each successive depression.

- 3) If no change occurs in the pedal height when pressed, the vacuum booster assembly is faulty.

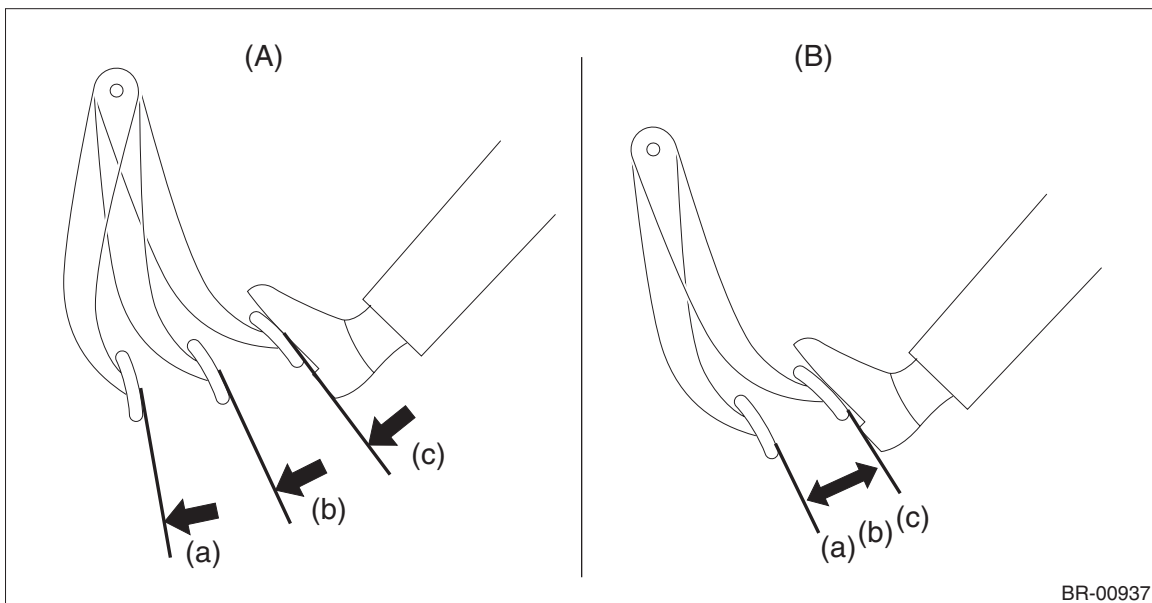

(A) Normal

(B) Not OK

(a) 1st

(b) 2nd

(c) 3rd

NOTE:

- In case of defective operation, inspect the condition of the check valve and vacuum hose as well.
- Replace them if faulty, and perform the test again.
- If no improvement is observed, check precisely with gauges.

Brake Booster

BRAKE

• Check operation

1) While the engine is OFF, depress the brake pedal several times applying the same pedal force, to check for a change in pedal height.

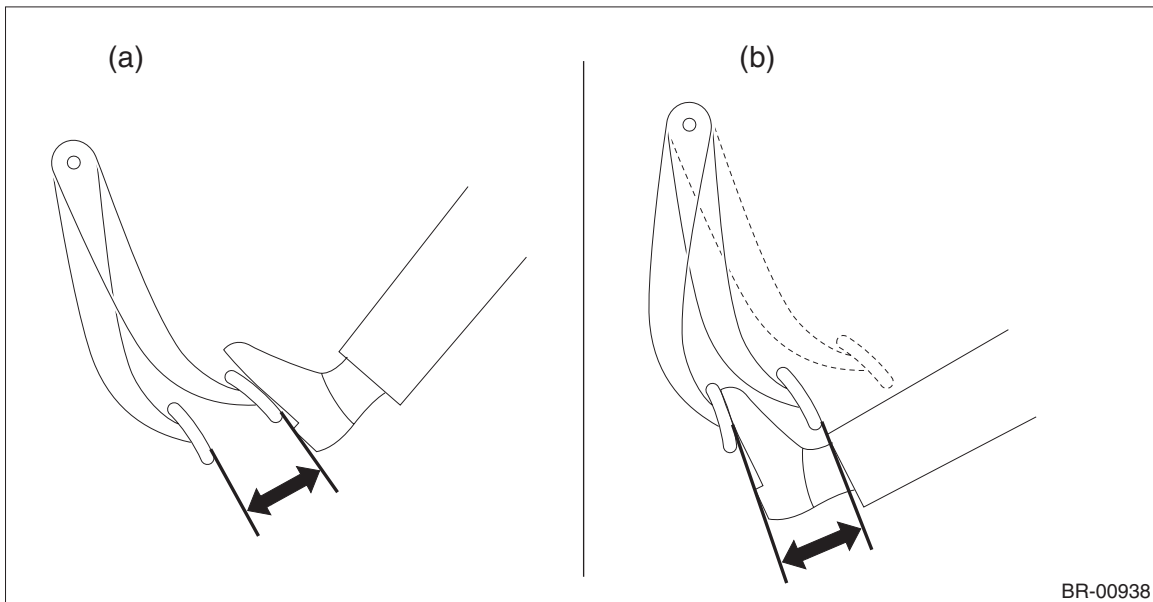

(a) When engine is stopped

(b) When engine is started

2) With the brake pedal depressed, start the engine.

3) As the engine starts, the brake pedal should move slowly toward the floor. If the pedal height does not change, the vacuum booster assembly is faulty.

NOTE:

If a faulty part is detected after inspection, check precisely with measuring devices.

• Loaded air tightness check

Depress the brake pedal while the engine is running, and turn the engine to OFF while the pedal is depressed.

Keep the pedal depressed for 30 seconds. If the pedal height does not change, the function of vacuum booster assembly is normal. If the pedal height increases, it is faulty.

NOTE:

If a faulty part is detected after inspection, check precisely with measuring devices.

2. OPERATION CHECK WHEN USING MEASURING DEVICES

CAUTION:

When checking operation, be sure to apply the parking brake securely.

• Check with measuring devices

Connect a measuring device as shown in the figure. After bleeding air from the pressure gauge, perform each check.

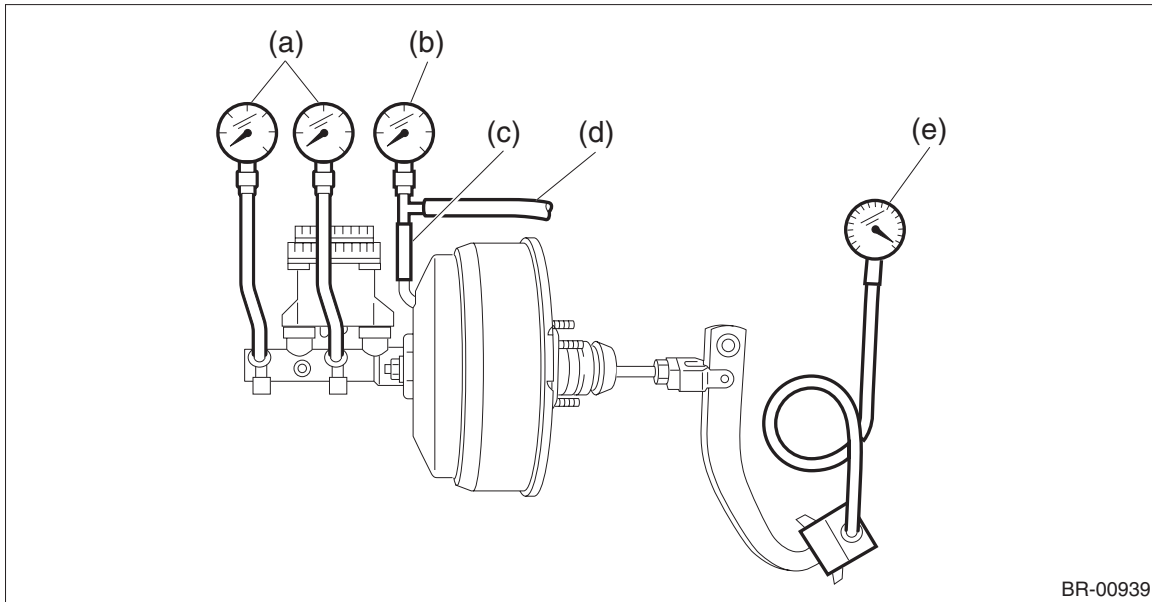

BR-00939

- | | | |
|--------------------|------------------|-----------------------|
| (a) Pressure gauge | (c) Adapter hose | (e) Pedal force gauge |
| (b) Vacuum gauge | (d) Vacuum hose | |

• Air tightness check

1) Start the engine and keep it running at idle until vacuum pressure indicates 66.7 kPa (500 mmHg, 19.69 inHg) while the brake pedal is not depressed.

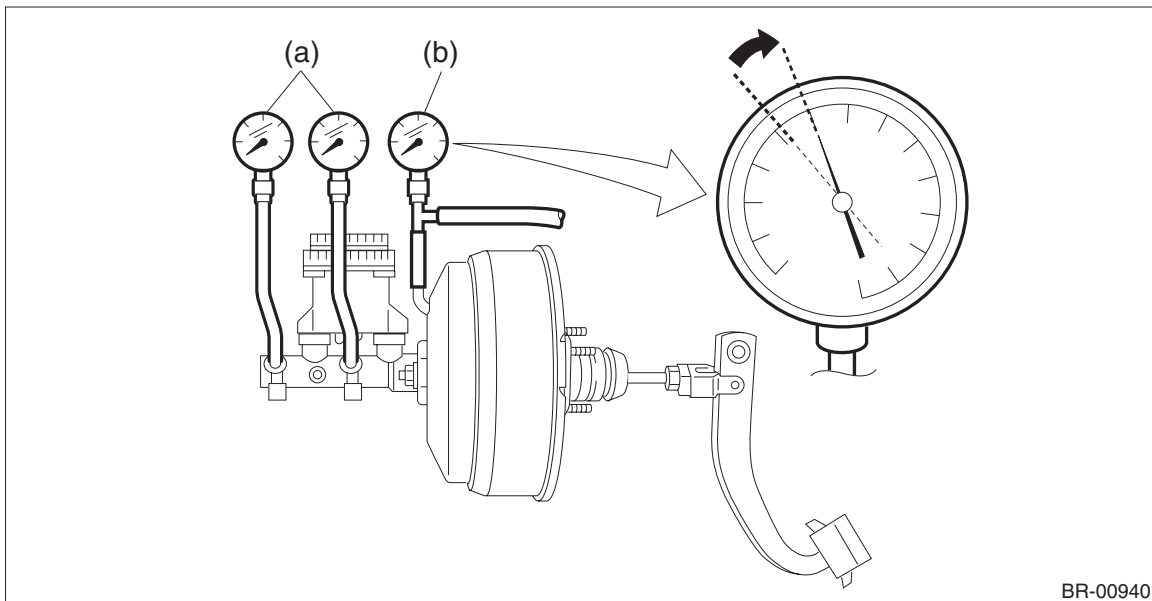

BR-00940

- | | |
|--------------------|------------------|
| (a) Pressure gauge | (b) Vacuum gauge |
|--------------------|------------------|

Brake Booster

BRAKE

2) Stop the engine and check the vacuum pressure.

If the value matches the following standard, the vacuum booster assembly function is normal.

Vacuum pressure: standard

The range of vacuum pressure drop within 15 seconds after stopping the engine is 3.3 kPa (25 mm-Hg, 0.98 inHg) or less.

If a faulty part is detected after inspection, it may result from one of the following causes.

- Check valve malfunction
- Leak from vacuum hose
- Leak from shell joint section or stud bolt welded section
- Damaged diaphragm
- Leak from valve body seal and bearing section
- Leak from plate and seal assembly section
- Leak from poppet valve assembly section

• Loaded air tightness check

1) Start the engine and depress the brake pedal with a pedal force of 196 N (20 kgf, 44 lbf).

2) Keep the engine running at idle and the pedal depressed until vacuum pressure of the vacuum gauge indicates 66.7 kPa (500 mmHg, 19.69 inHg).

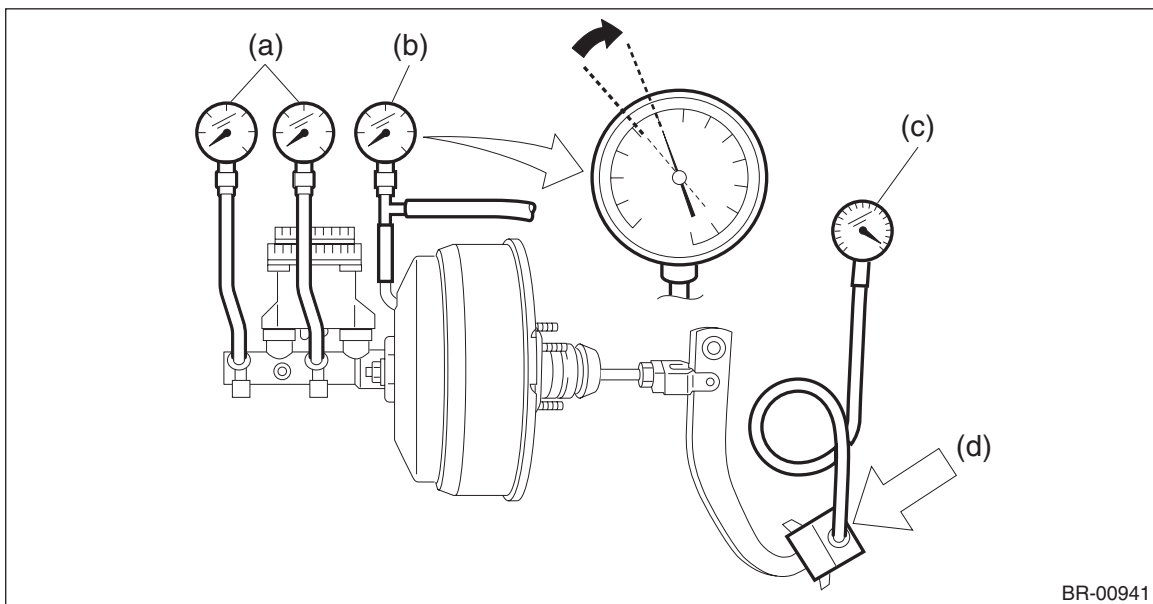

- (a) Pressure gauge
(b) Vacuum gauge

(c) Pedal force gauge

(d) Depressed

3) Stop the engine and check the vacuum gauge.

If the value matches the following standard, the vacuum booster function is normal.

Vacuum pressure: standard

The range of vacuum pressure drop within 15 seconds after stopping the engine is 3.3 kPa (25 mm-Hg, 0.98 inHg) or less.

If a faulty part is detected after inspection, refer to "AIR TIGHTNESS CHECK".

<Ref. to BR-53, INSPECTION, Brake Booster.>

4) If the vacuum booster assembly is faulty, replace it with a new part.

• **Lack of boost action check**

- 1) Turn the engine OFF, and set the value of the vacuum gauge to “0”.
- 2) Check the fluid pressure when the brake pedal is depressed. The pressure must be greater than the specification listed.

Brake pedal force: N (kgf, lbf)	147 (15, 33)	294 (30, 66)
Fluid pressure: kPa (kgf/cm ² , psi)	533 (5, 77)	1,551 (16, 225)

• **Boosting action check**

- 1) Set the vacuum gauge reading to 66.7 kPa (500 mmHg, 19.69 inHg) with the engine running.
- 2) Check the fluid pressure when the brake pedal is depressed. The pressure must be greater than the specification listed.

Brake pedal force: N (kgf, lbf)	147 (15, 33)	294 (30, 66)
Fluid pressure: kPa (kgf/cm ² , psi)	6,177 (63, 896)	11,273 (115, 1,635)