

14.Brake Pedal

A: REMOVAL

1. CVT MODEL

- 1) Disconnect the ground cable from battery and wait for at least 60 seconds before starting work.
- 2) Remove the cover assembly - instrument panel LWR driver.

CAUTION:

When removing the cover assembly - instrument panel LWR driver, be sure to pull it toward you. If attempting to remove by turning it upward, the claws may be damaged.

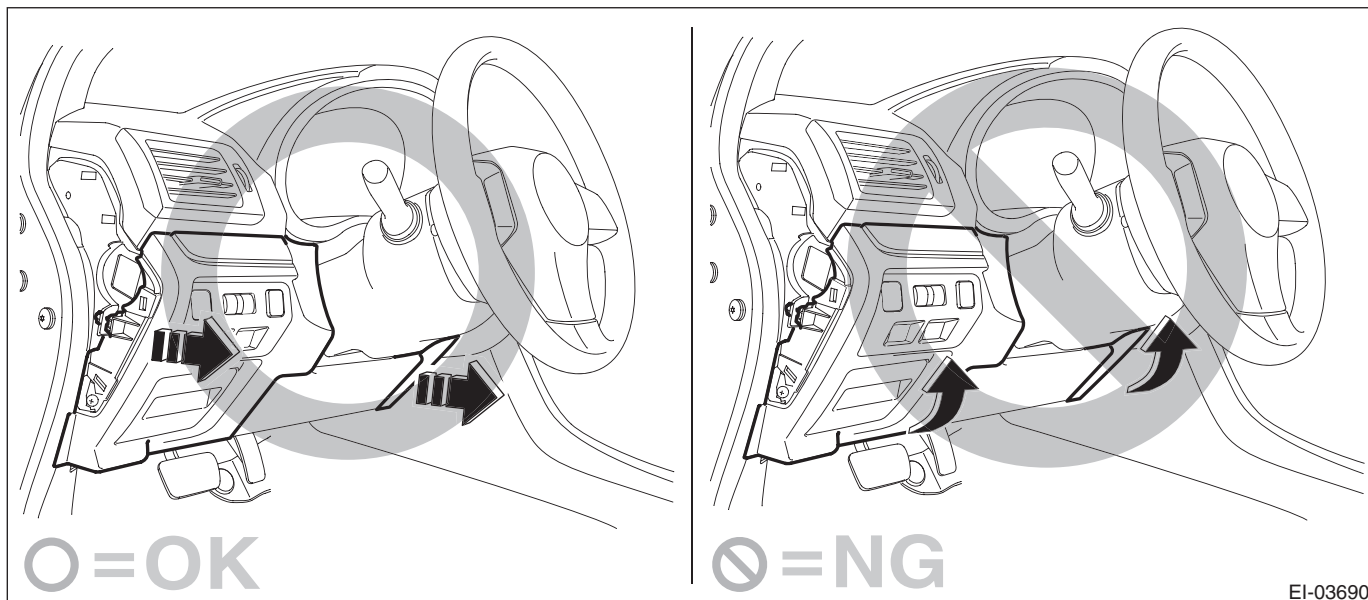

- (1) Remove the clips, and remove the cover - instrument panel side LH.

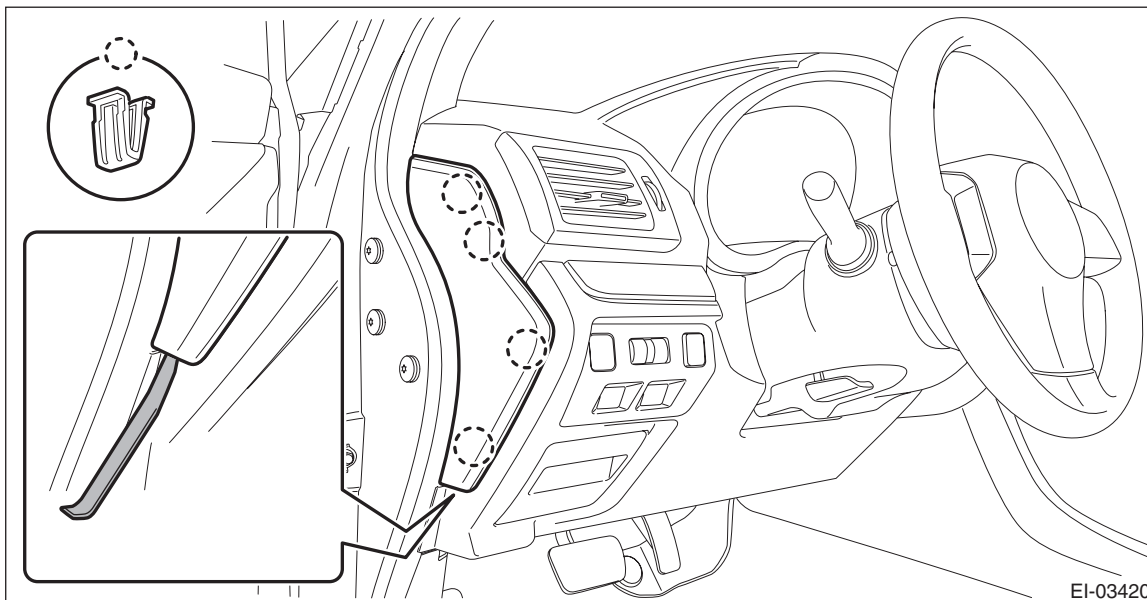

NOTE:

Using a plastic remover, open the cover - instrument panel side LH.

- (2) Remove the screws and release the clips and claws.

(3) Disconnect the harness connectors, and remove the cover assembly - instrument panel LWR driver INN and OUT.

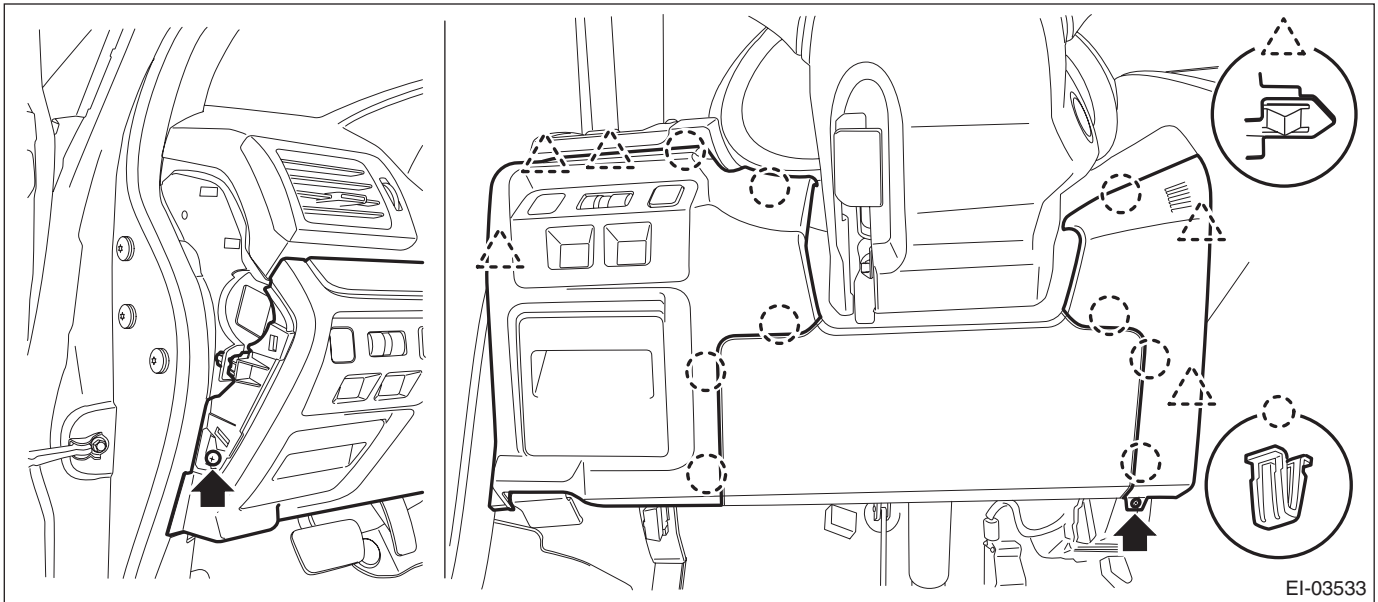

3) Remove the nuts to remove the knee airbag module and disconnect the harness connector. <Ref. to AB-33, KNEE AIRBAG MODULE, PROCEDURE, Airbag Connector.>

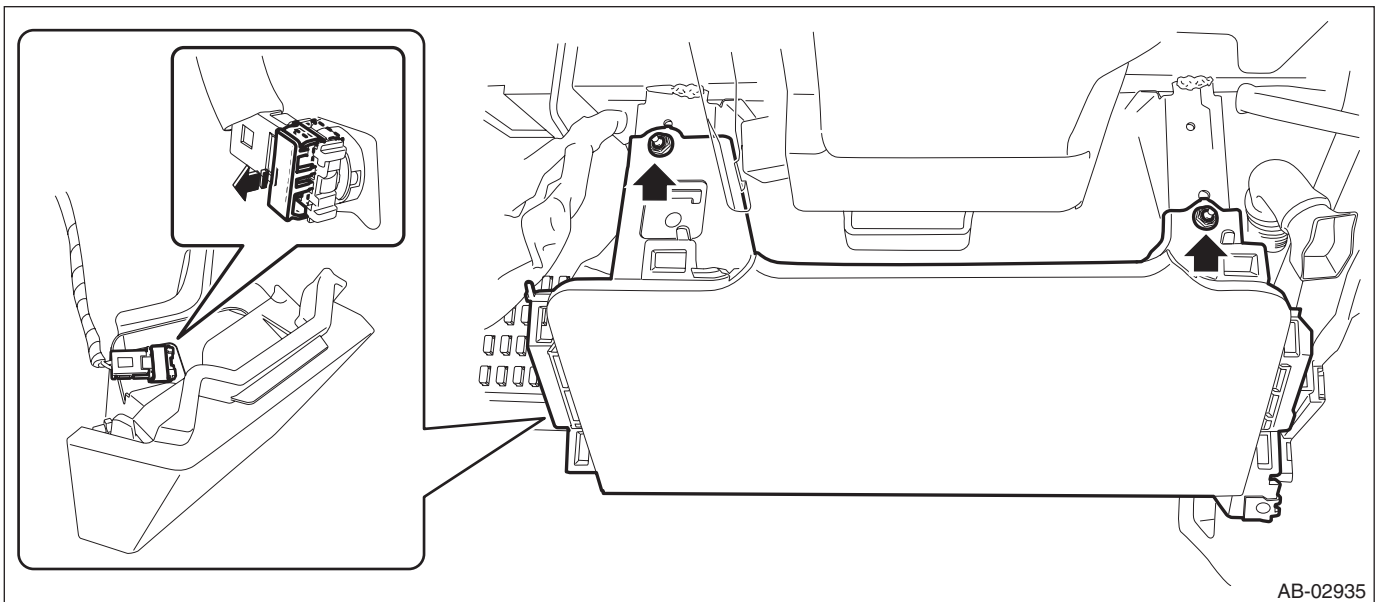

Brake Pedal

BRAKE

- 4) Remove the brake pedal assembly.
 - (1) Disconnect the switch - stop light connector.
 - (2) Remove the snap pin (a) and clevis pin (b), and remove the operating rod from the brake pedal.

CAUTION:

- Be careful not to apply excessive force to the operating rod when handling the operating rod. The angle may change by $\pm 3^\circ$, and it may result in damage to power piston cylinder.
- Do not change the push rod length.

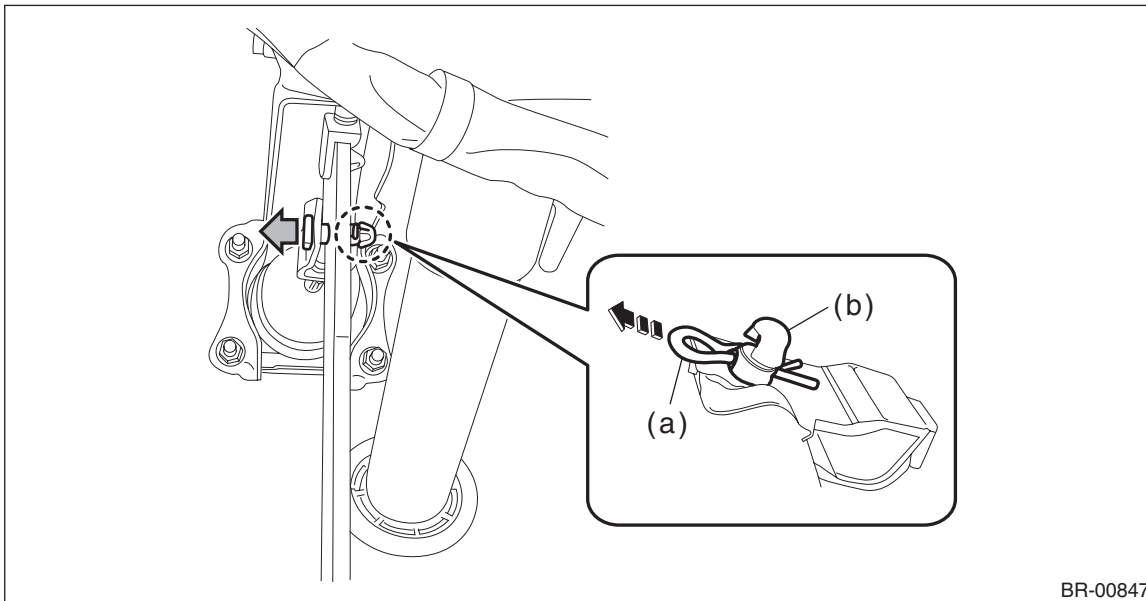

- (3) Remove the bolt and nut, and then detach the brake pedal assembly.

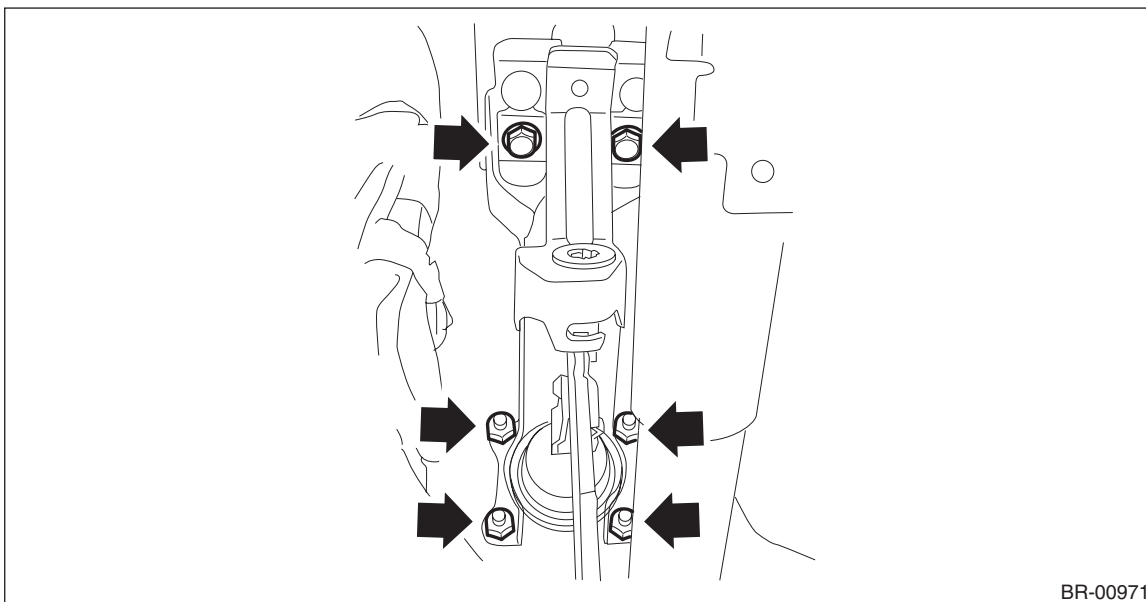

2. MT MODEL

NOTE:

Brake pedal is integrated with the clutch pedal.

For removal procedures of the brake pedal, refer to Clutch section. <Ref. to CL-22, REMOVAL, Clutch Pedal.>

B: INSTALLATION

1) Install each part in the reverse order of removal.

CAUTION:

- Apply grease to the snap pin to prevent the operating rod from wear.
- Replace the clevis pin with new parts, and apply thin coat of NIGTIGHT LYW No. 2 grease to the clevis pin.

Tightening torque:

Brake pedal: 18 N·m (1.84 kgf-m, 13.3 ft-lb)

Knee airbag module: 7.5 N·m (0.76 kgf-m, 5.5 ft-lb)

2) Check that the brake light operate properly.

3) Check the brake pedal after installation. <Ref. to BR-69, INSPECTION, Brake Pedal.>

C: INSPECTION

1) Move the pad - brake pedal in a horizontal direction with a force of approx. 10 N (1 kgf, 2 lbf), and check that the pedal deflection is in the range of specifications.

CAUTION:

If excessive deflection is noted, replace with a new bushing.

Deflection of brake pedal:

Wear limit: 5.0 mm (0.197 in) or less

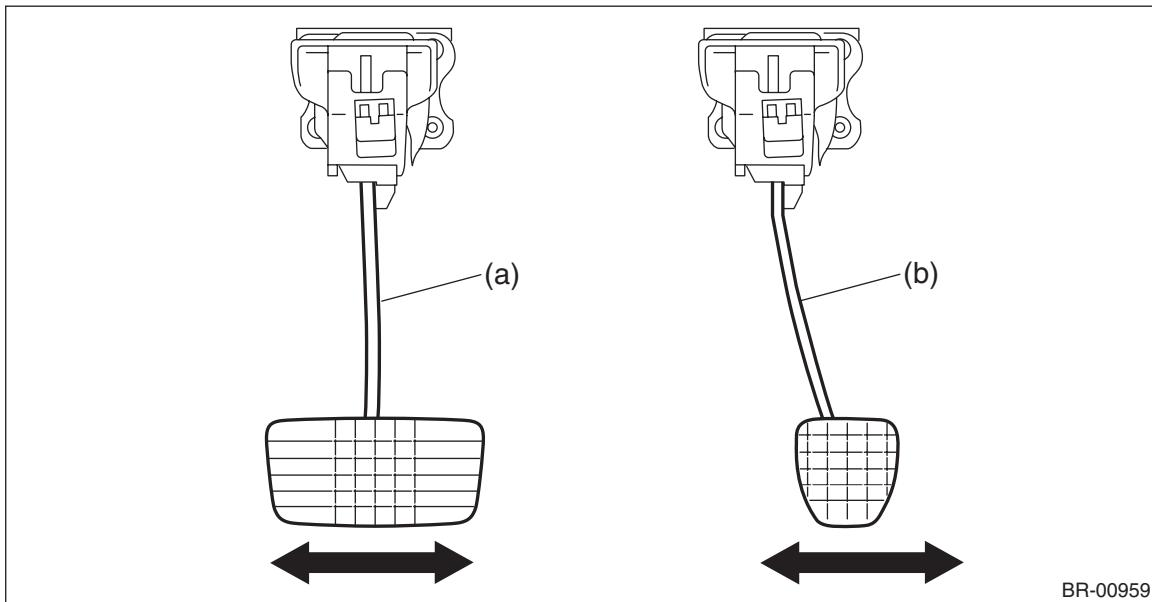

BR-00959

(a) Brake pedal (except for MT model) (b) Brake pedal (MT model)

Brake Pedal

BRAKE

2) Check the position of the pedal pad.

Pedal height L:

140 — 150 mm (5.51 — 5.91 in)

Brake pedal free play A:

0.5 — 2 mm (0.020 — 0.079 in) [When pulling the brake pedal upward with a force of less than 10 N (1 kgf, 2 lbf).]

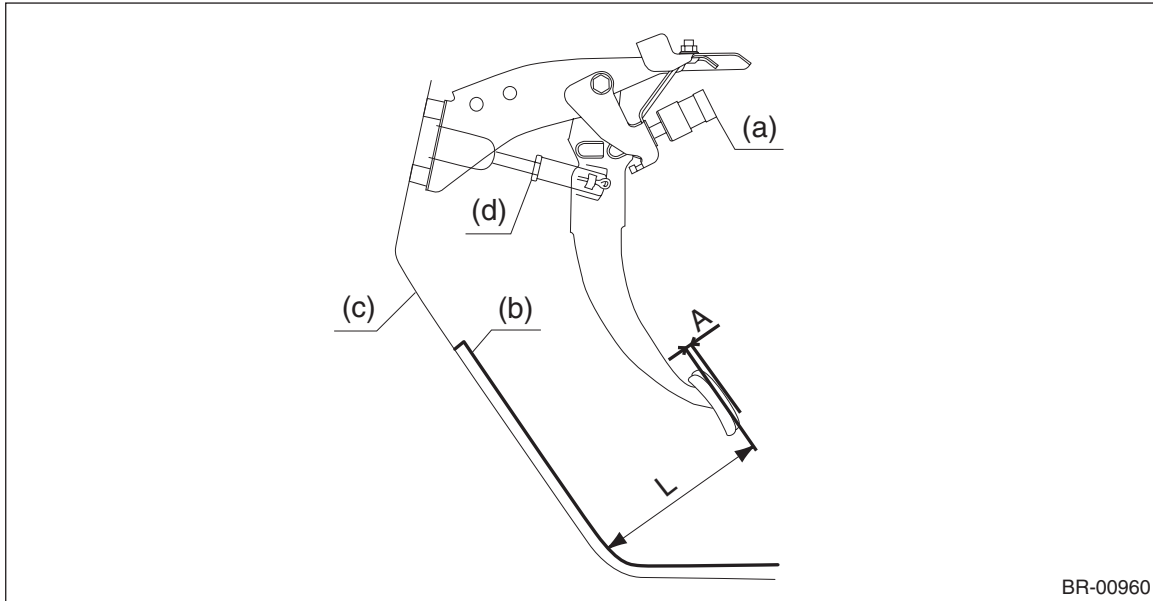

BR-00960

(a) Switch - stop light

(c) Toe board

(d) Brake booster operating rod

(b) Mat

3) If it is not within the specification, loosen the lock nuts of vacuum booster operating rod, and rotate the rod to adjust the pedal height L within the specification.

4) Tighten the lock nut.

Tightening torque:

Operating lock nut: 22 N·m (2.24 kgf-m, 16.2 ft-lb)

NOTE:

Check the brake pedal height. When adjusting, also adjust the switch - stop light.