

Parking Brake Lever

PARKING BRAKE

2. Parking Brake Lever

A: REMOVAL

- 1) Set the wheel stoppers to tires.
- 2) Remove the headrest assembly - front.
- 3) Move the passenger's seat towards the front.
- 4) Remove the driver's seat outside the vehicle.
 - (1) Tilt the backrest assembly forward and move the front seat to the front most position.
 - (2) Remove the cover - bolt rear (A) and remove the bolts.

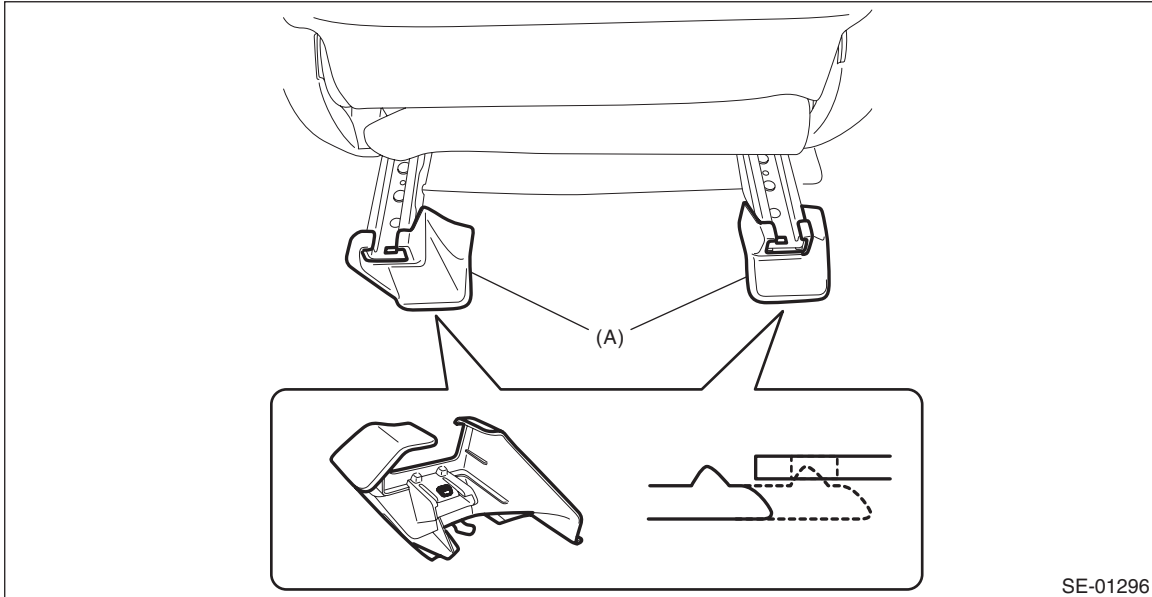

SE-01296

- (3) Move the front seat to the rearmost position, and remove the bolts.
- 5) Disconnect the ground cable from battery and wait for at least 60 seconds before starting work.

CAUTION:

The airbag system is fitted with a backup power supply. After disconnecting the battery ground cable, the airbag may operate if you do not wait for 60 seconds before starting the service of airbag system.

- 6) Disconnect the connector under the front seat.
 - Seat belt warning light connector (driver's seat)
 - Side airbag connector <Ref. to AB-31, SIDE AIRBAG MODULE, PROCEDURE, Airbag Connector.>
 - Seat heater connector (model with seat heater)
- 7) Take out the front seat from the vehicle.

CAUTION:

Be careful not to damage the body.

Parking Brake Lever

PARKING BRAKE

8) Remove the console box assembly.

(1) Release the claws, and then remove the boot - parking brake.

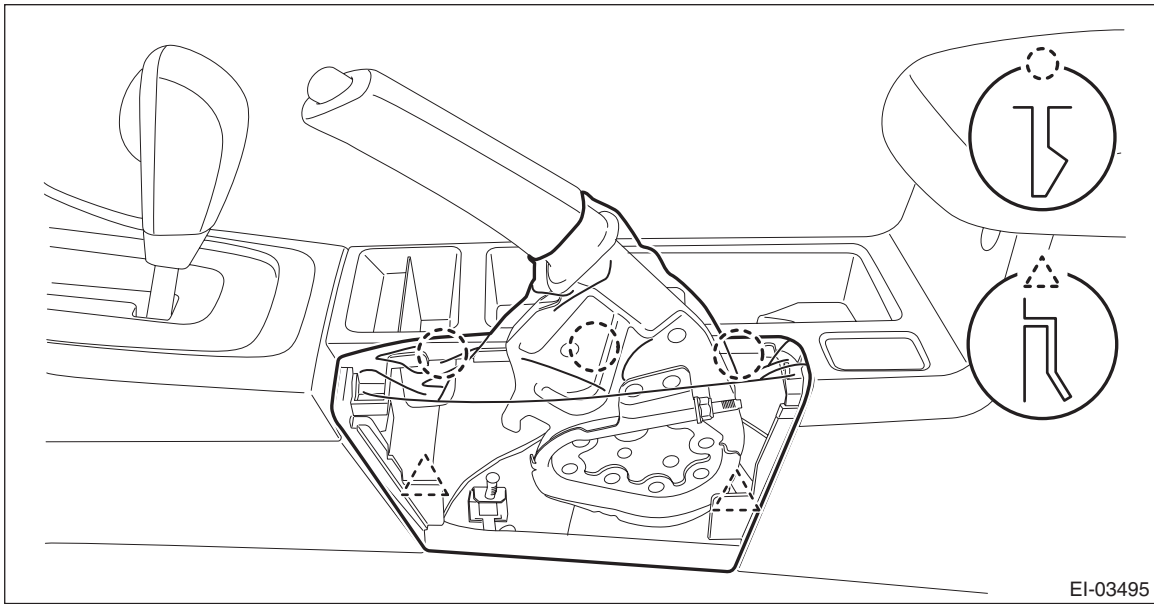

(2) Move the seat forward, and remove the bolts after detaching the left and right caps.

(3) Remove the screws and clips, disconnect the harness connector and remove the console box assembly.

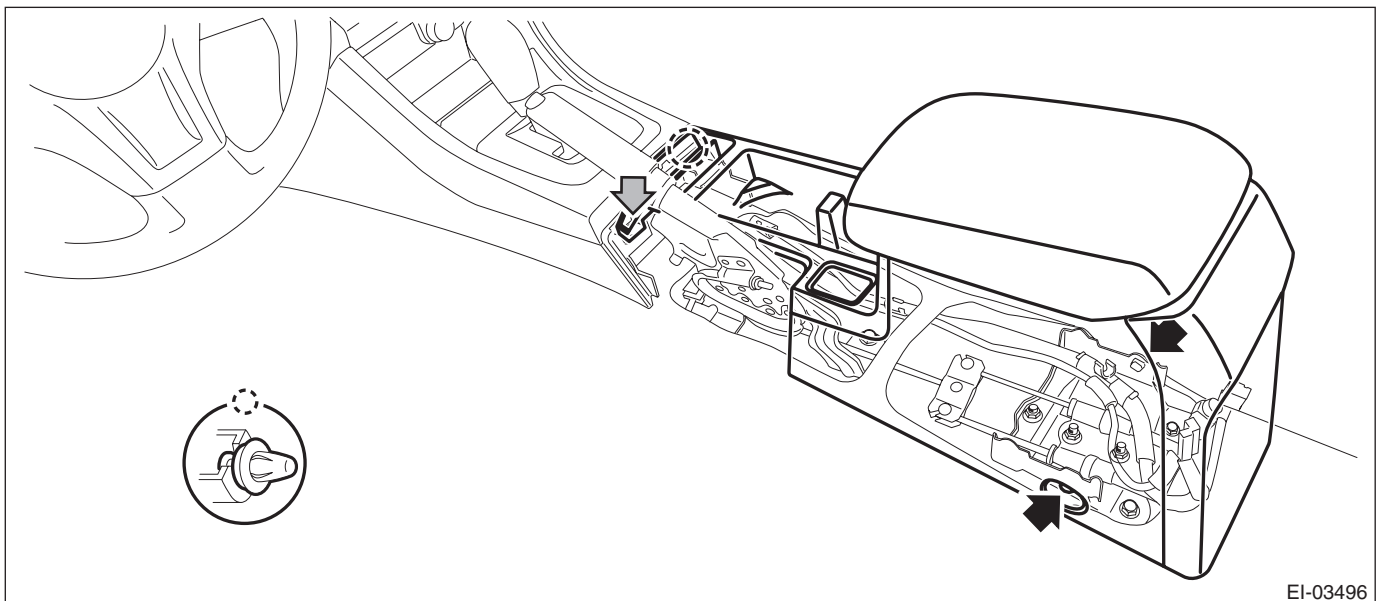

Parking Brake Lever

PARKING BRAKE

9) Remove the lever assembly - hand brake.

(1) Disconnect the connector (a) of the switch assembly - hand brake.

(2) Remove the adjusting nut (b).

CAUTION:

A self-locking nut is used for the adjusting nut of parking cable. Therefore, replace the self-locking nut with a new one when disassembling.

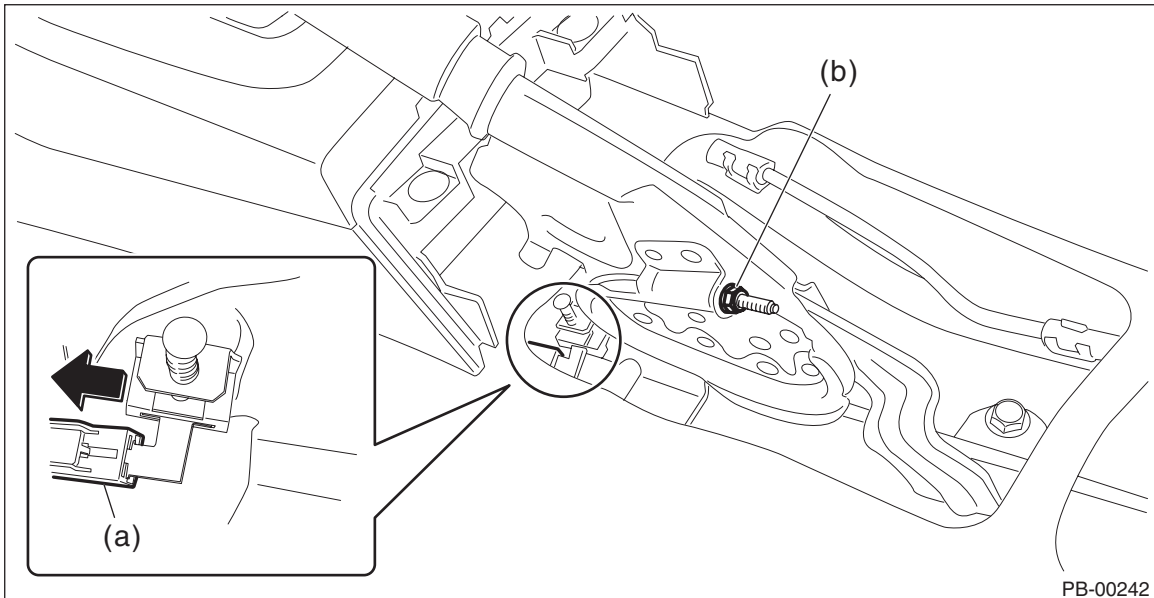

(3) Remove the bolt, and then remove the lever assembly - hand brake.

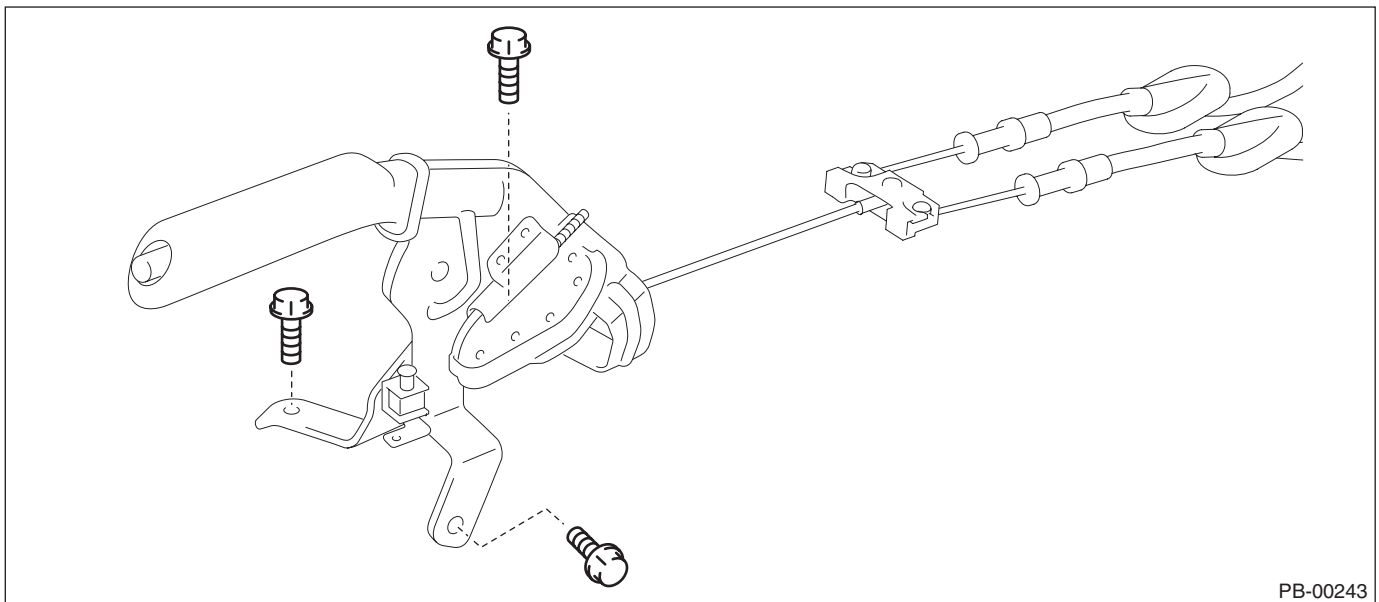

10) Remove the inner cable end (a) from the equalizer (b).

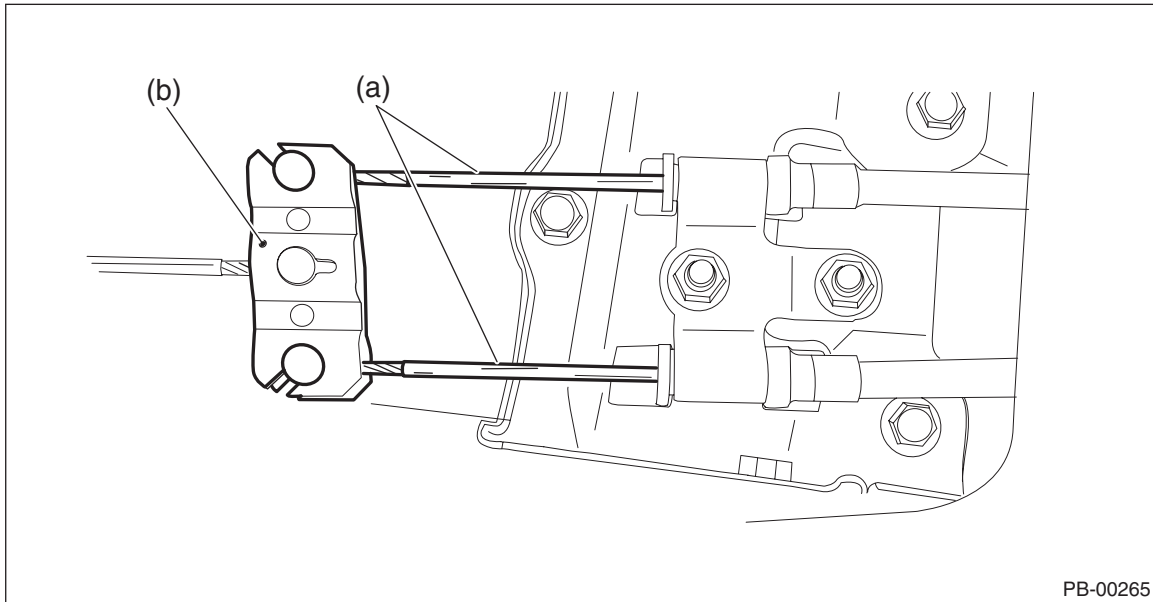

B: INSTALLATION

1) Install each part in the reverse order of removal.

CAUTION:

- The front seat mounting bolts differ between the front mounting points and the rear mounting points. When installing the front seat, make sure that you are using correct bolts at correct positions.
- Tighten the slide rail assembly installing bolts in the order as shown in the figure, in several steps by gradually increasing the torque until they reach the specified torque.

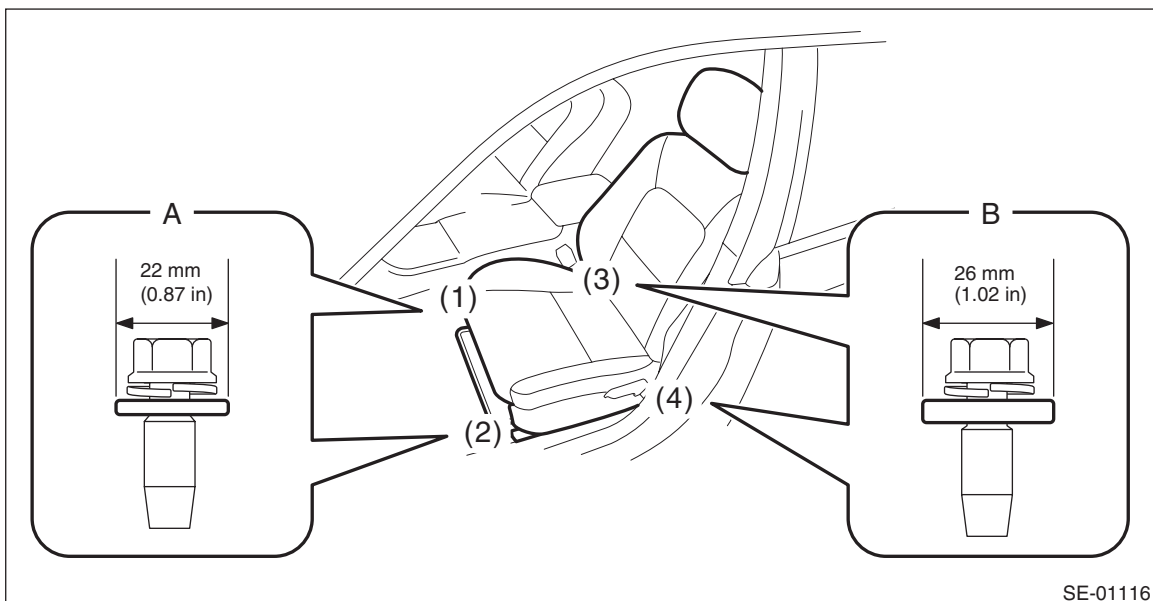

- Front (bolt A): Washer diameter 22 mm (0.87 in)
- Rear (bolt B): Washer diameter 26 mm (1.02 in)

Tightening torque:

Front seat assembly: 53 N·m (5.40 kgf-m, 39.1 ft-lb)

Tightening torque:

Lever assembly - hand brake: 18 N·m (1.84 kgf-m, 13.3 ft-lb)

Console box assembly: 6.5 N·m (0.66 kgf-m, 4.8 ft-lb)

Parking Brake Lever

PARKING BRAKE

- 2) Install a new adjusting nut (self-locking nut).
- 3) Be sure to adjust the lever stroke. <Ref. to PB-8, ADJUSTMENT, Parking Brake Lever.>

C: INSPECTION

1. LEVER ASSY

- 1) Operate the lever assembly - hand brake 3 to 4 times and fully return the lever assembly - hand brake.
- 2) While slowly pulling up the lever assembly - hand brake, count the notches.

Lever stroke:

7 to 8 notches when pulled with a force of 200 N (20.4 kgf, 45 lbf)

If it is not within the specified value, adjust the parking brake. <Ref. to PB-22, ADJUSTMENT, Parking Brake Assembly (Rear Disc Brake).>

2. SWITCH ASSEMBLY

- 1) Measure the resistance between the switch assembly - hand brake and chassis ground.

Preparation tool:

Circuit tester

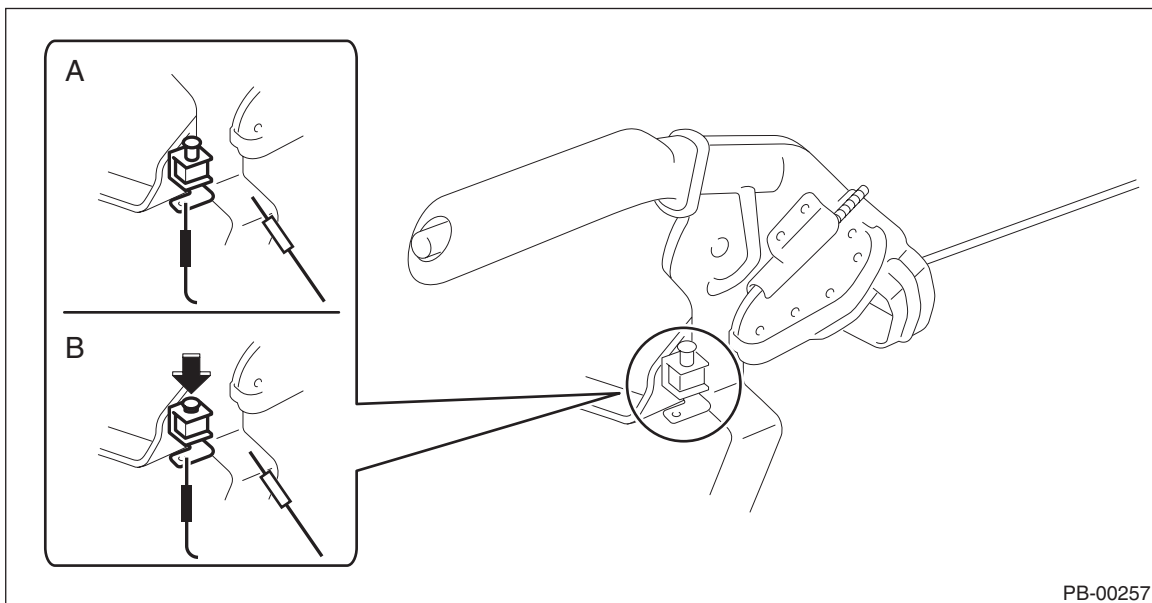

PB-00257

	Switch position	Standard
A	When shaft is free (ON)	Less than 1 Ω
B	When shaft is pressed in (OFF)	10 k Ω or more

If it is not within the specified value, replace the switch assembly - hand brake.

D: ADJUSTMENT

Adjust the parking lever stroke. <Ref. to PB-23, LEVER STROKE, ADJUSTMENT, Parking Brake Assembly (Rear Disc Brake).>