

## 4. Parking Brake Assembly (Rear Disc Brake)

### A: REMOVAL

- 1) Release the parking brake.
- 2) Lift up the vehicle, and then remove the rear wheels.
- 3) Remove the brake hose bracket.
- 4) Remove the attachment bolts and remove the rear disc brake caliper assembly.

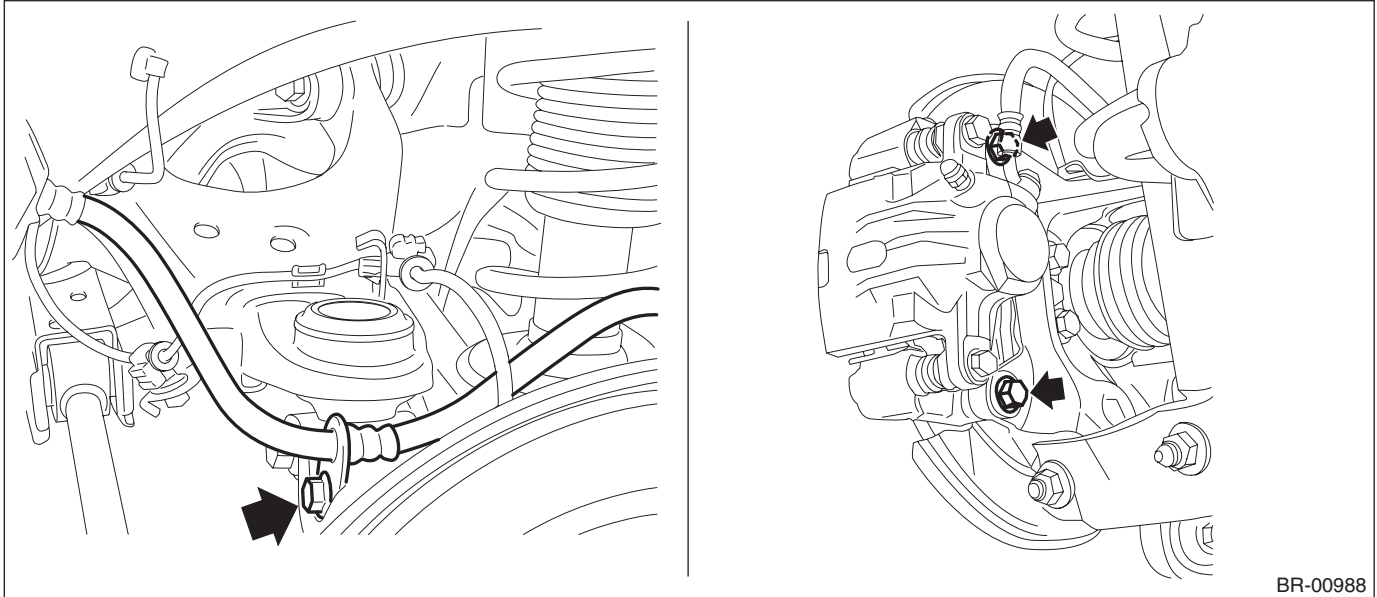

- 5) Suspend the rear disc brake caliper assembly so that the brake hose is not stretched.

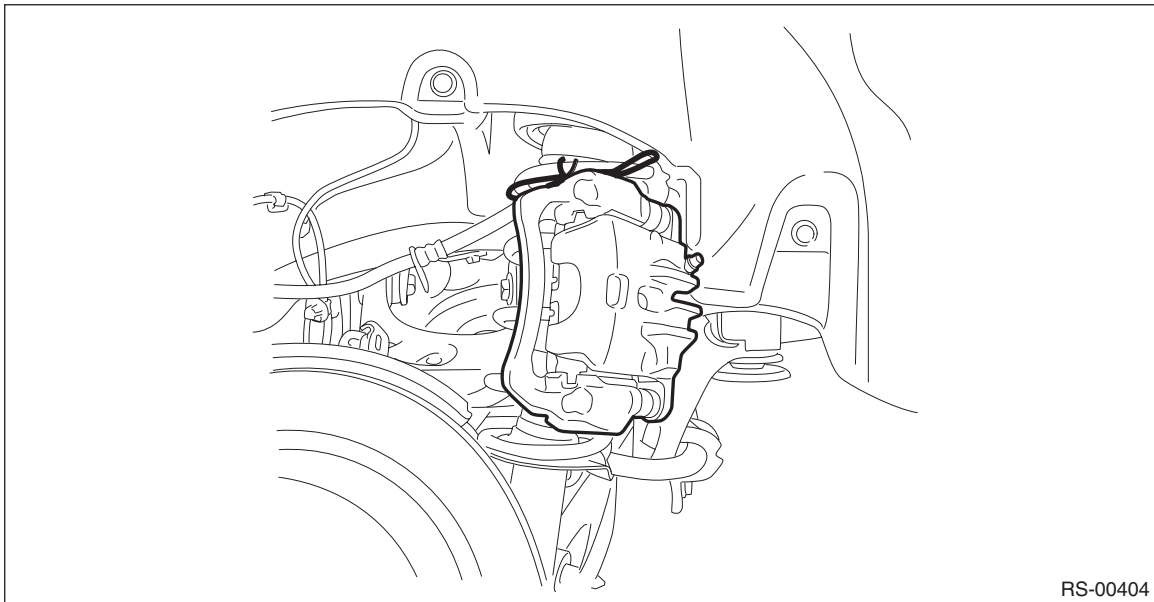

# Parking Brake Assembly (Rear Disc Brake)

## PARKING BRAKE

6) Mark an alignment mark on the rear disc brake rotor and the hub unit COMPL - rear axle, and then remove the rear disc rotor.

### NOTE:

If the rear disc rotor is difficult to remove, try the following two methods in order.

(1) Remove the adjusting hole cover (A) for the disc rotor, and rotate the adjuster assembly - rear brake using a flat tip screwdriver until the brake shoe moves far enough from the disc rotor.

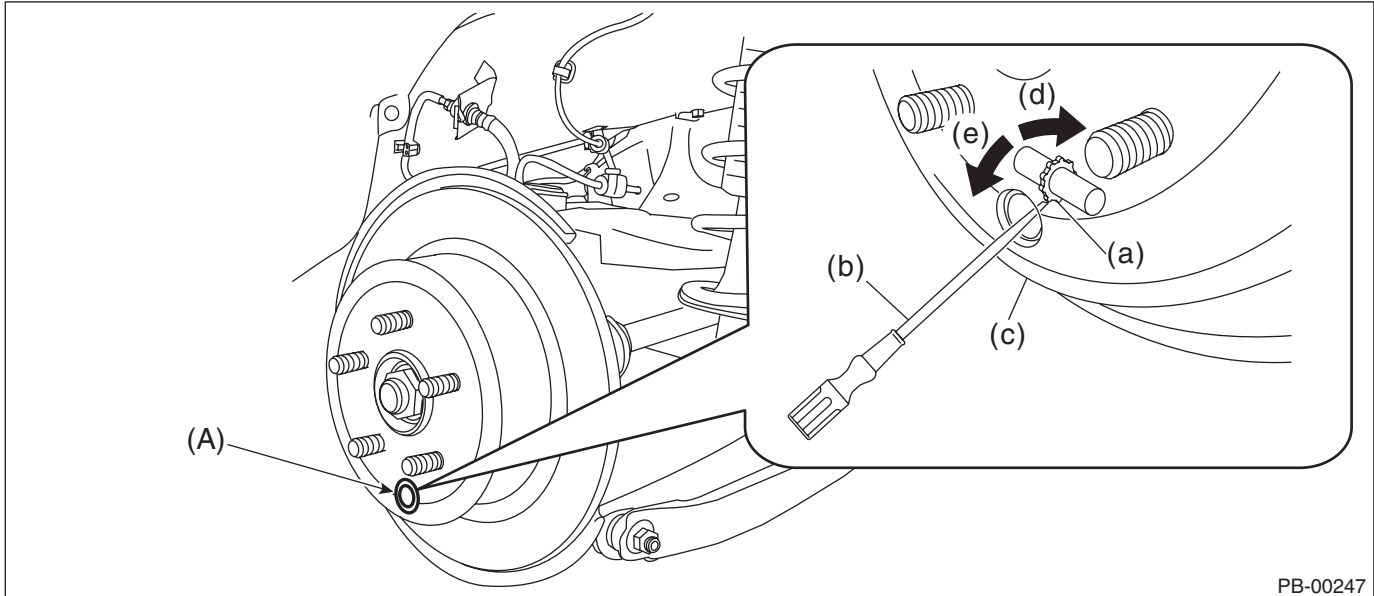

PB-00247

- |                                |   |  |
|--------------------------------|---|--|
| (a) Adjuster ASSY - rear brake | (c) Rear disc rotor                       | (e) Shorten the adjuster ASSY - rear brake |
| (b) Flat tip screwdriver       | (d) Extend the adjuster ASSY - rear brake |  |

(2) If the rear disc rotor is seized on the hub unit COMPL - rear axle, drive the rear disc rotor out by pushing it with two 8 mm bolts inserted through the holes (A) on the rotor.

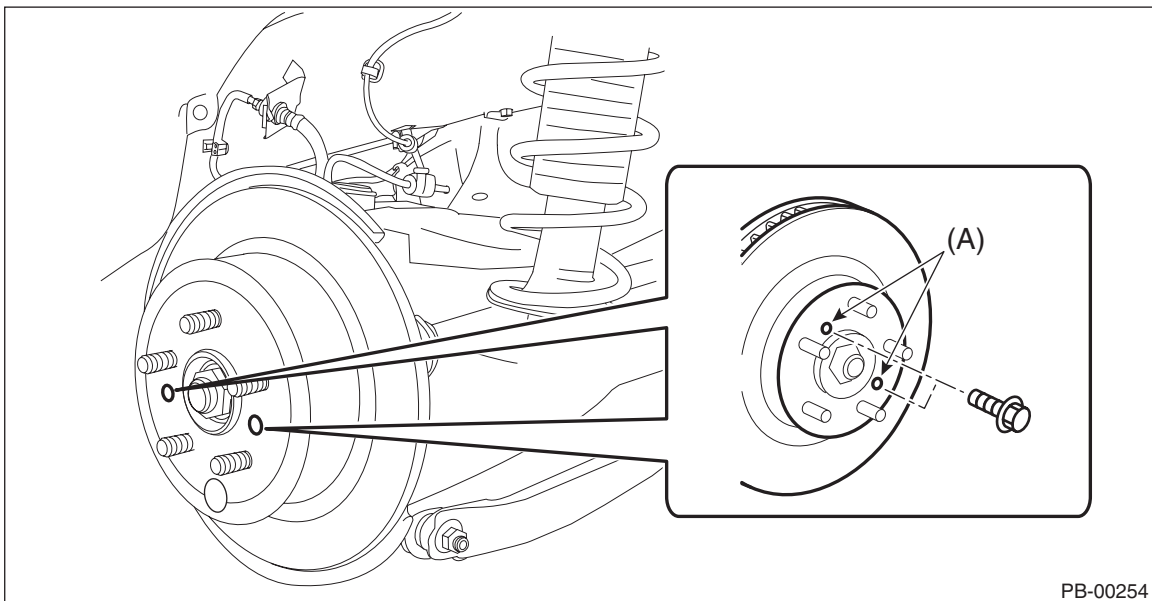

PB-00254

# Parking Brake Assembly (Rear Disc Brake)

PARKING BRAKE

- 7) Remove the spring - primary shoe return and the spring - secondary shoe return.

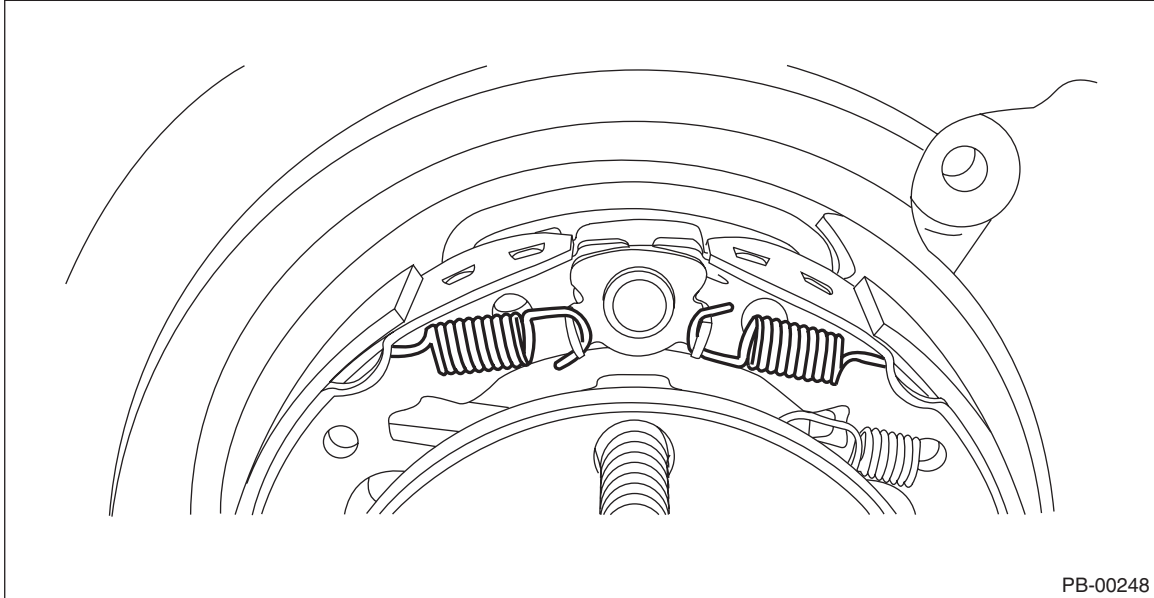

- 8) Remove the parking brake shoe on the primary side.

- (1) Remove the cup - shoe hold-down (a) and the spring - adjuster, and remove the parking brake shoe (b).

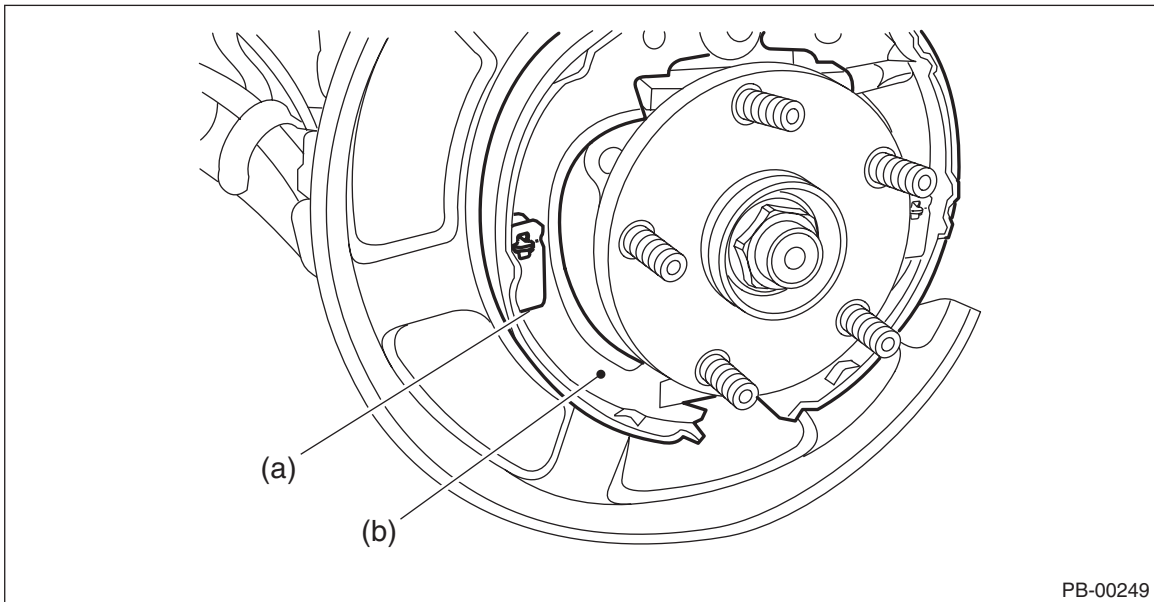

- (2) Remove the strut - brake and the spring - strut.  
(3) Remove the adjuster assembly - rear brake.

# Parking Brake Assembly (Rear Disc Brake)

## PARKING BRAKE

9) Remove the parking brake shoe on the secondary side.

(1) Rotate the cup - shoe hold-down in the direction of the front side of the vehicle.

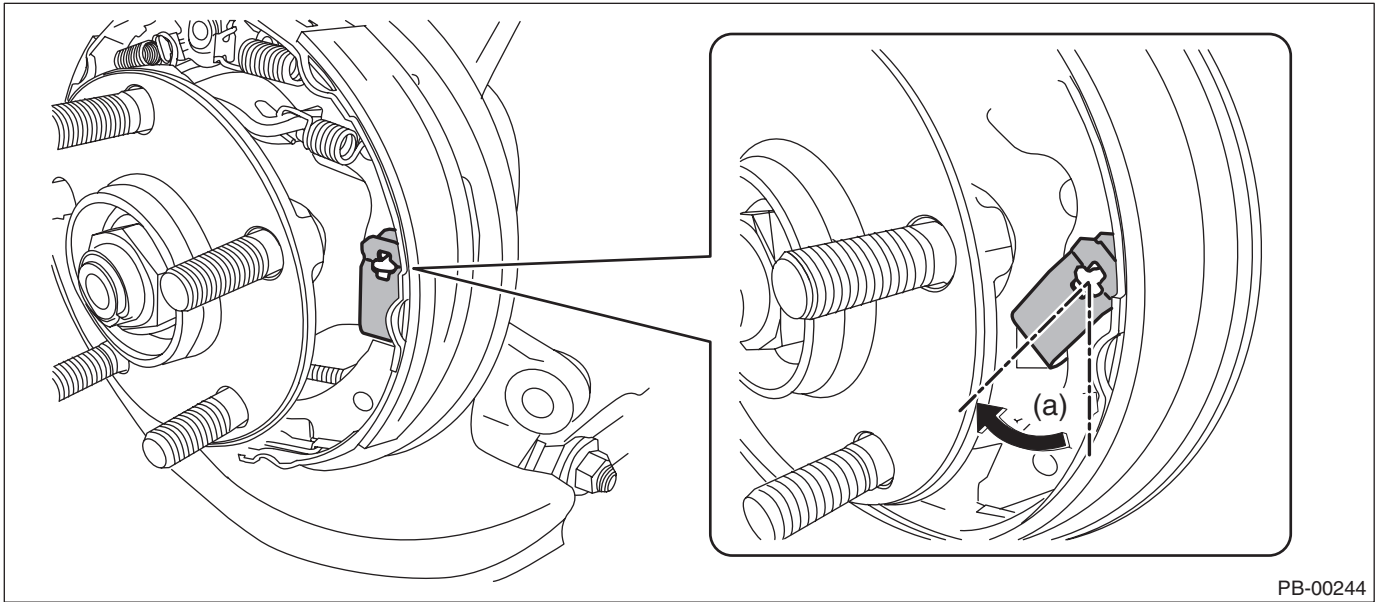

PB-00244

(a) Approx. 45°

(2) Press and shorten the cup - shoe hold-down.

(3) Rotate the pin - secondary shoe hold-down in the opposite direction, and pull out the pin - shoe hold-down.

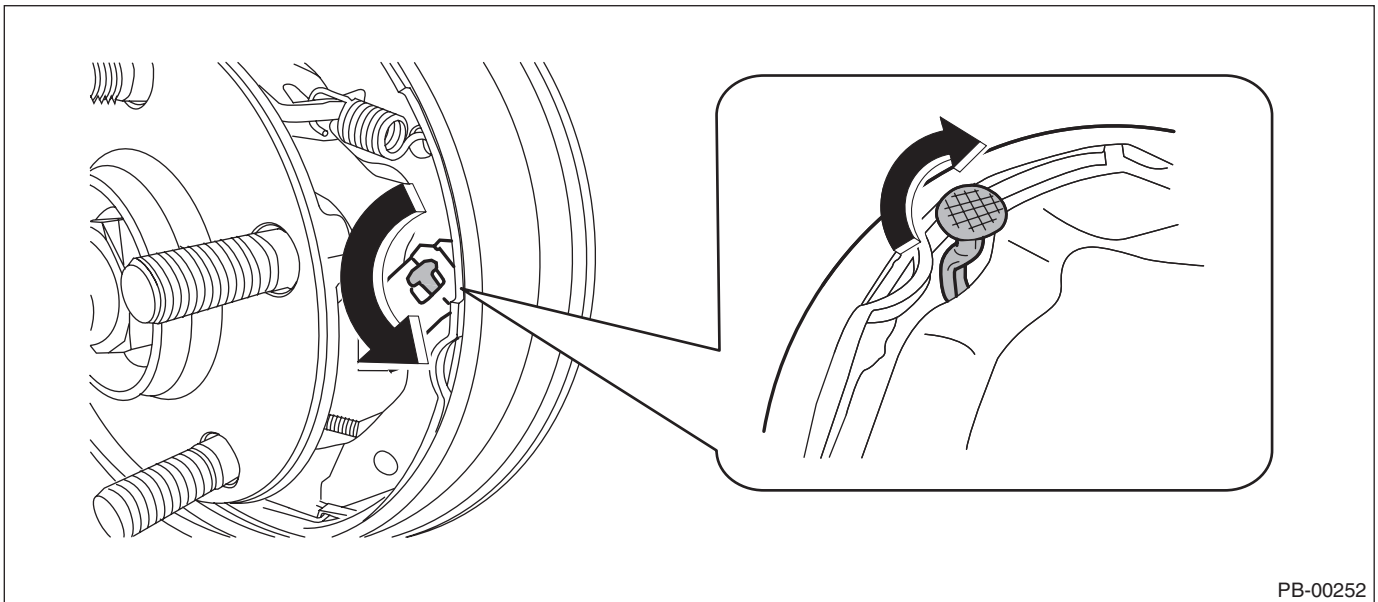

PB-00252

10) Remove the cable assembly - hand brake cable (a) from the parking lever - rear (b).

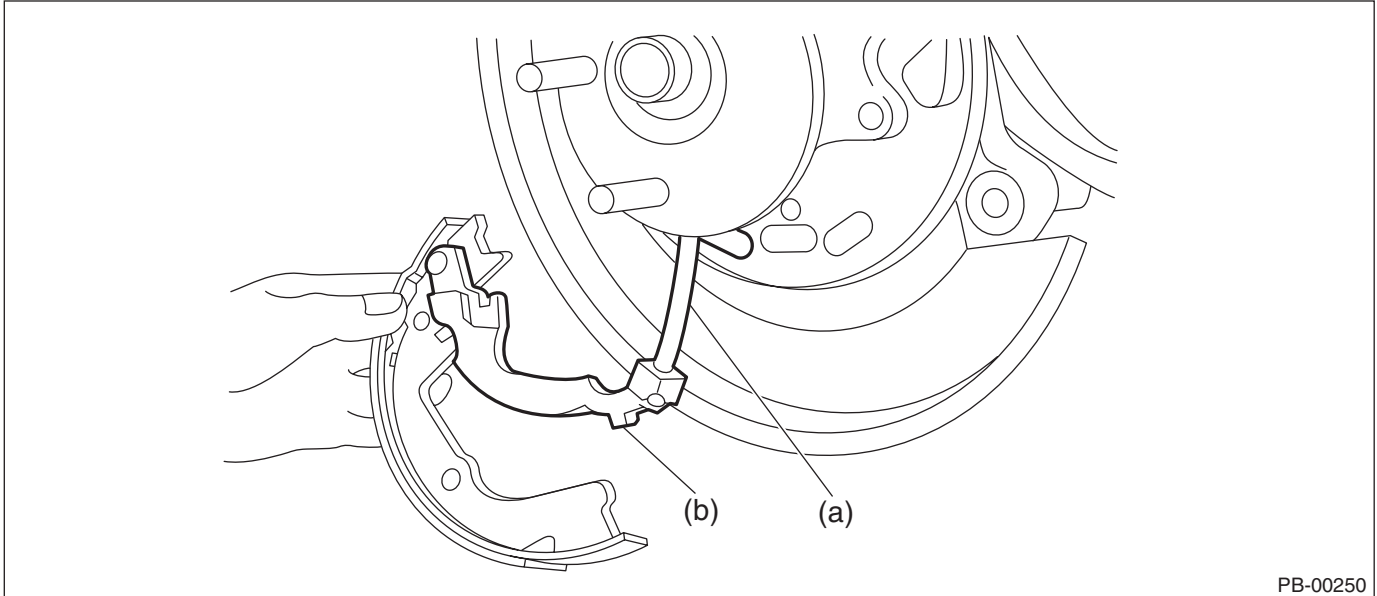

11) Remove the retainer - rear brake from the secondary side parking brake shoe. Remove the parking lever - rear from the brake shoe.

## B: INSTALLATION

### CAUTION:

**Be sure the lining surface is free from brake fluid and grease.**

1) Apply brake grease to the following locations.

#### **Brake grease:**

***Molykote 44MA (Part No. 26648FJ000)***

- Six contact surfaces of the parking brake shoe rim and back plate - rear brake
- Contact surface of the parking brake shoe and the anchor pin
- Contact surface of the parking lever assembly - rear and the strut - brake
- Contact surface of the parking brake shoe and the adjuster assembly - rear brake
- Contact surface of the parking brake shoe and the strut - brake
- Contact surface of the parking lever - rear and the parking brake shoe

2) Install the spring washer - rear brake and the lever to the secondary side parking brake shoe pin, and lock the retainer - rear brake securely.

3) Install the cable assembly - parking brake to the lever.

# Parking Brake Assembly (Rear Disc Brake)

## PARKING BRAKE

4) Attach the adjuster assembly - rear brake and the spring - adjuster to the parking brake shoe.

### NOTE:

Install the adjuster assembly - rear brake with the screw section facing to the direction shown in the figure below.

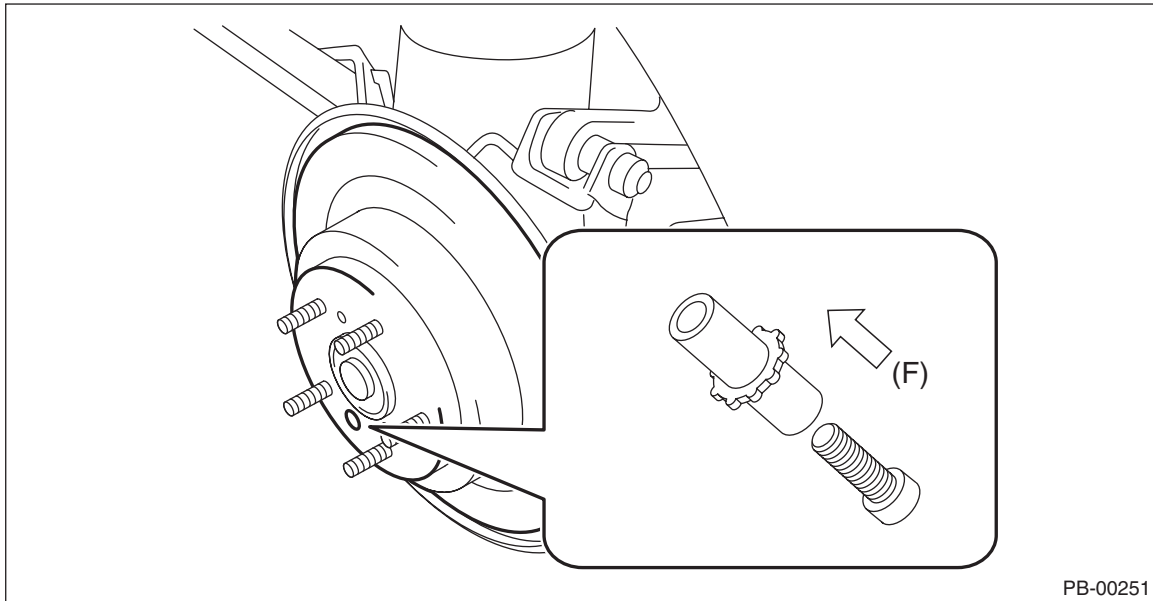

(F) Left wheel: front side of vehicle,  
right wheel: rear side of vehicle

5) Check that the cable assembly - parking brake does not fall from the cable guide.

6) Install the parking brake shoes to the back plate - rear brake with the pins - shoe hold-down and the cups - shoe hold-down.

### NOTE:

- Do not reversely install the pin - primary shoe hold-down (a) and the pin - secondary shoe hold-down (b).
- When installing the pin - secondary shoe hold-down (b), face the convex portion to the rear of the vehicle not to contact with the parking lever - rear.

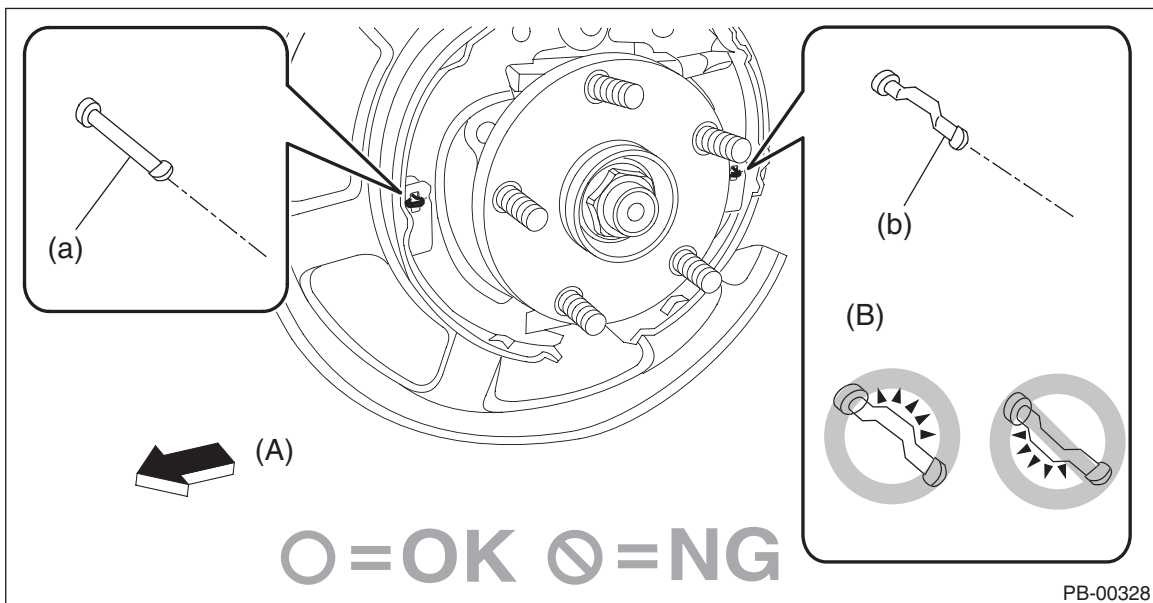

(A) Front side of vehicle

(B) Orientation of pin - shoe hold-down relative to the front of the vehicle

7) Install the strut - brake and the spring - strut to the parking brake shoes.

**NOTE:**

Install the spring - strut so that it comes towards the front side of the vehicle.

8) Install the return springs on the primary side first, and then the secondary side.

9) Install the brake disc rotor and the brake caliper assembly.

10) Install the brake hose bracket.

**Tightening torque:**

*Refer to "COMPONENT" of "General Description". <Ref. to BR-4, COMPONENT, General Description.>*

11) Adjust the parking brake. <Ref. to PB-22, ADJUSTMENT, Parking Brake Assembly (Rear Disc Brake).>

12) Install the rear wheels.

**Tightening torque:**

**120 N·m (12.24 kgf-m, 88.5 ft-lb)**

13) If new parking brake shoes are replaced, drive the vehicle to break-in the parking brake lining.

(1) Drive the vehicle at approximately 35 km/h (22 MPH) or more.

(2) While pressing the button of lever assembly - hand brake, pull the lever assembly - hand brake with a force of 150 N (15.3 kgf, 33.7 lbf).

(3) Drive the vehicle for about 200 m (0.12 mile) in this condition.

(4) Wait 5 to 10 minutes for the parking brake to cool down. Repeat steps (1) through (3) again.

(5) After breaking-in, re-adjust the parking brakes.

## C: INSPECTION

1) Measure the inner diameter of the rear disc rotor. If scoring or worn is found on the disc, replace the rear disc rotor.

**Disc rotor inner diameter:**

**Specification: 170 mm (6.69 in)**

**Service limit: 171 mm (6.73 in)**

2) Measure the lining thickness. If it exceeds the limit, replace the brake shoe.

**Lining thickness:**

**Specification: 3.5 mm (0.14 in)**

**Service limit: 1.5 mm (0.059 in)**

**NOTE:**

Replace the right and left parking brake shoe as a set.

# Parking Brake Assembly (Rear Disc Brake)

## PARKING BRAKE

### D: ADJUSTMENT

#### 1. SHOE CLEARANCE

- 1) Return the lever assembly - hand brake completely.
- 2) Loosen the adjusting nut, and make the cable free.
- 3) Remove the adjusting hole cover (A) from the rear disc rotor.
- 4) Insert the flat tip screwdriver (B) into the brake adjustment hole (A), and rotate the adjuster assembly - rear brake (a) until the parking brake shoe contacts the rear disc rotor.

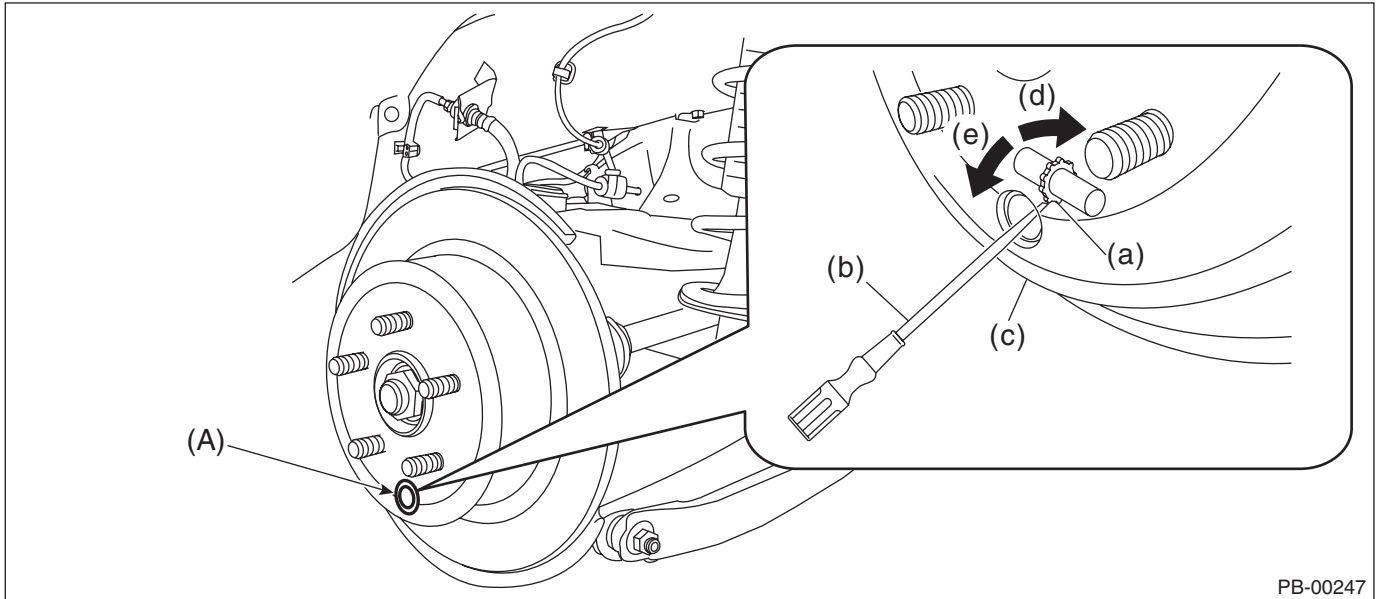

PB-00247

- |                                |   |  |
|--------------------------------|---|--|
| (a) Adjuster ASSY - rear brake | (c) Disc rotor                            | (e) Shorten the adjuster ASSY - rear brake |
| (b) Flat tip screwdriver       | (d) Extend the adjuster ASSY - rear brake |  |

- 5) Loosen the adjuster assembly - rear brake by 8 notches in the direction of the arrow (e).

#### CAUTION:

- Check there is no brake drag.
- Make sure that the adjuster assembly - rear brake is loosened by 8 notches. If it is not loosened sufficiently, dragging may occur.

- 6) Install the adjusting hole cover to the disc rotor.

- 7) Adjust the parking lever stroke. <Ref. to PB-23, LEVER STROKE, ADJUSTMENT, Parking Brake Assembly (Rear Disc Brake).>



## 2. LEVER STROKE

- 1) Adjust the shoe clearance before adjusting lever stroke. <Ref. to PB-22, SHOE CLEARANCE, ADJUSTMENT, Parking Brake Assembly (Rear Disc Brake).>
- 2) Release the claws, and then remove the boot - parking brake.

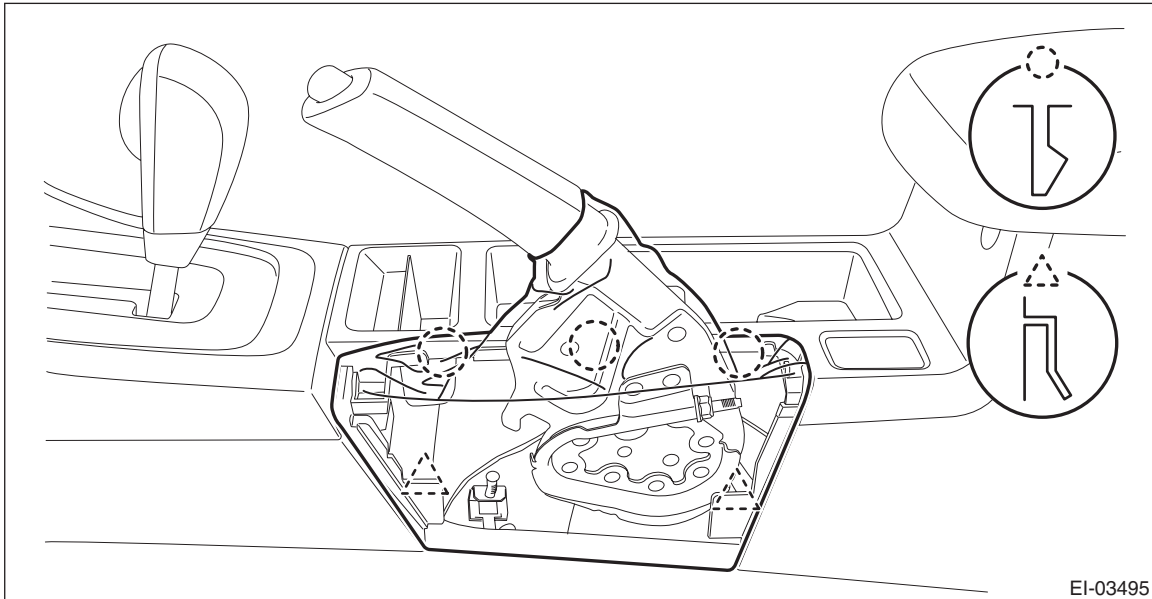

- 3) Pull the lever assembly - hand brake hard 3 to 5 times.
- 4) Turn the adjusting nut (a) until the lever stroke is at the specified value.

### **Lever stroke:**

**7 to 8 notches when pulled with a force of 200 N (20.4 kgf, 45 lbf)**

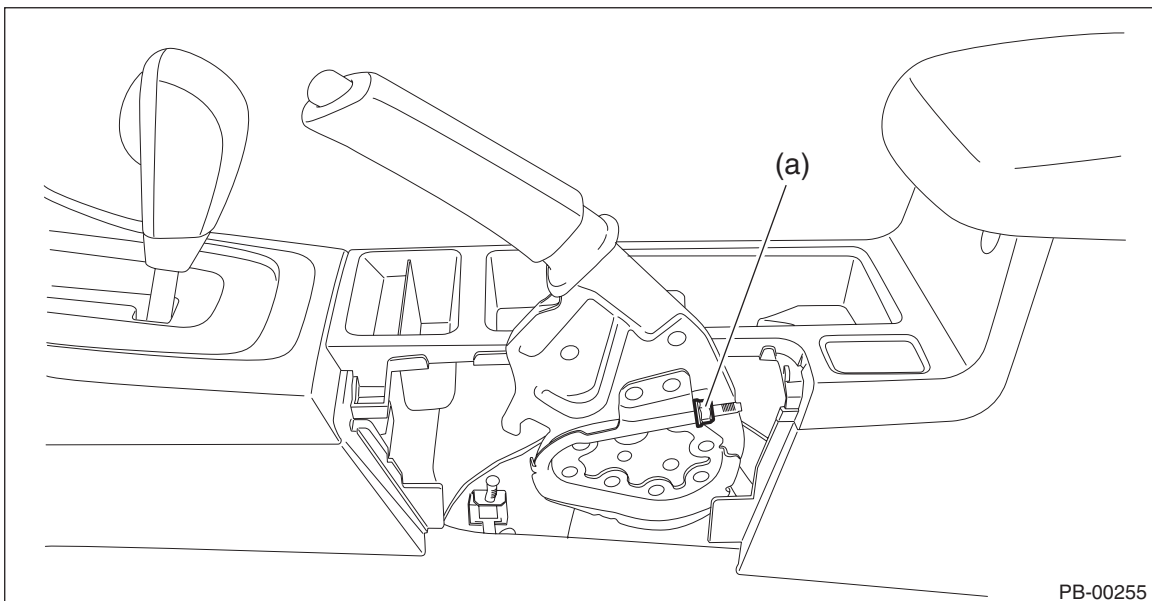

- 5) Check there is no brake drag.
- 6) Check that the brake warning light illuminates when the lever assembly - hand brake is operated.

### **NOTE:**

The light must illuminate when the first notch is reached after pulling the lever.

- 7) Install the boot - parking brake.