

Electric Power Steering Gearbox

POWER ASSISTED SYSTEM (POWER STEERING)

6. Electric Power Steering Gearbox

A: REMOVAL

CAUTION:

- The power steering control module continues to operate after the engine stops and calculate the temperature in the control module. Therefore, before starting service of the power steering system which requires disconnection of the connector, stop the engine and allow approx. 30 minutes until the control module becomes cold.

- Before removal or installation, be sure to remove any foreign matter (dust, moisture, oil, etc.) from the power steering control module connector.

1) Disconnect the ground cable from battery.

2) Adjust the tilt position of the column assembly - steering to the lowest position and lock the tilt lever.

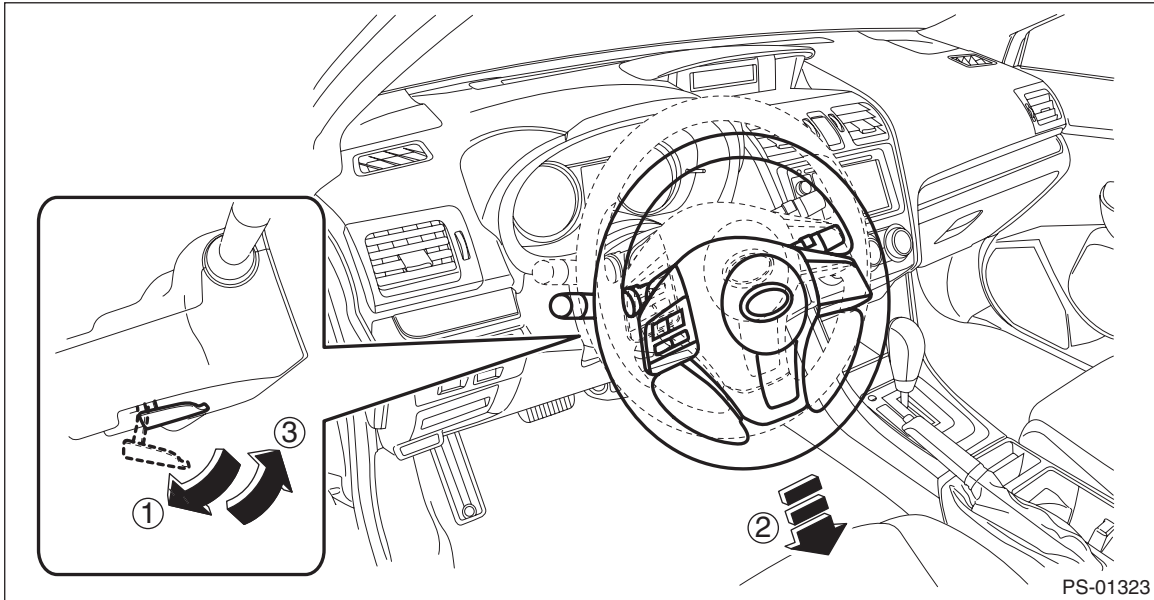

Electric Power Steering Gearbox

POWER ASSISTED SYSTEM (POWER STEERING)

3) Remove the universal joint assembly - steering.

(1) Place alignment marks on the universal joint assembly - steering.

NOTE:

Place alignment marks on the following positions.

- Between the column assembly - steering and the universal joint assembly - steering
 - Between the steering gearbox assembly and the universal joint assembly - steering
- (2) Remove the bolt, and remove the universal joint assembly - steering.

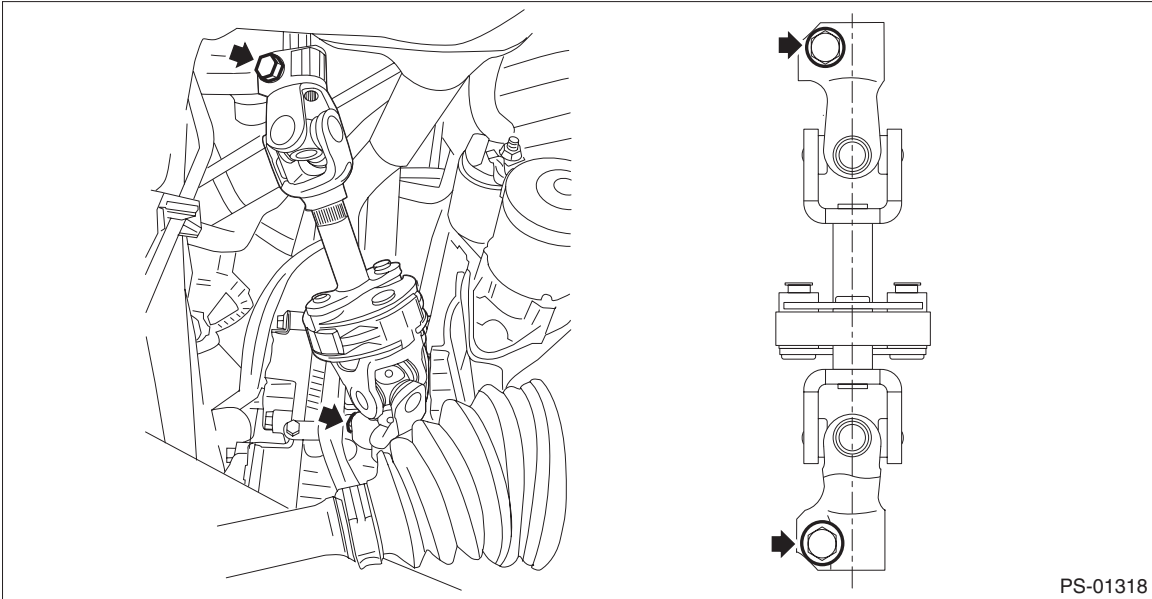

4) Prevent the steering wheel from turning using the seat belt.

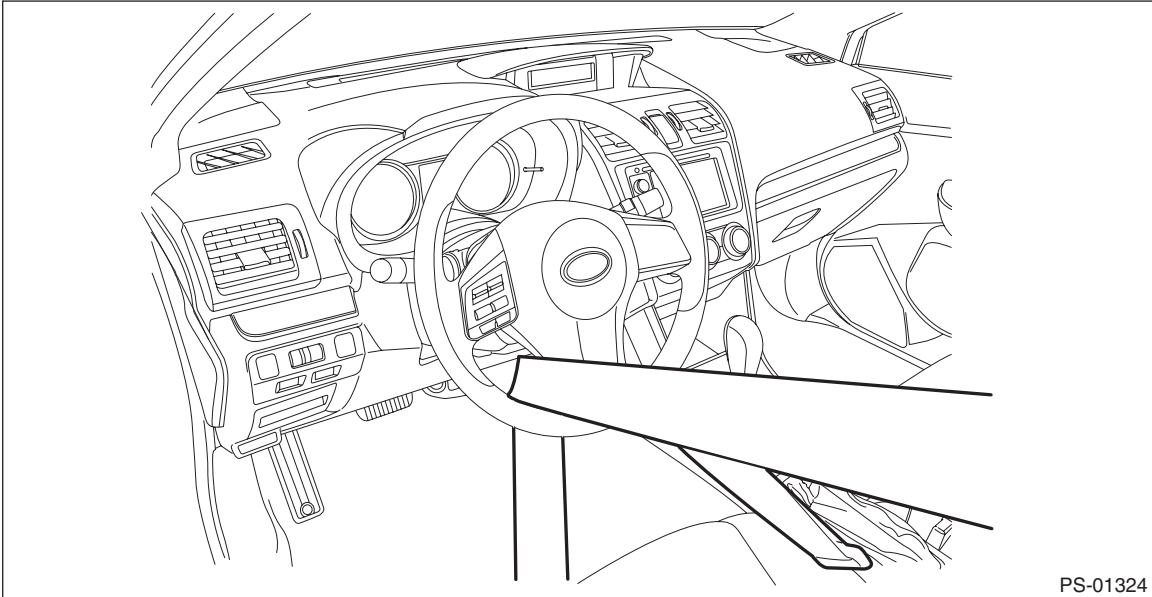

5) Disconnect the connector and harness clamp from power steering control module.

Electric Power Steering Gearbox

POWER ASSISTED SYSTEM (POWER STEERING)

6) Remove the bolts and clips, and remove the under cover - front.

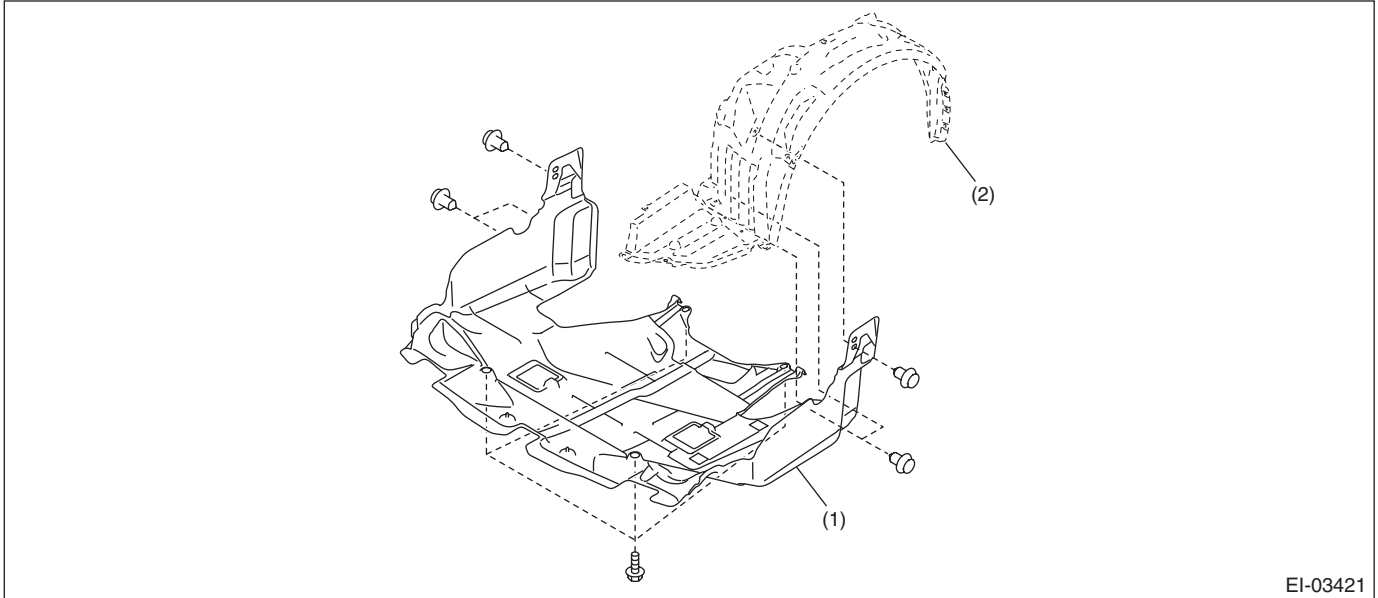

EI-03421

(1) Under cover - front

(2) Mud guard - front

7) Remove the front wheels.

8) Disconnect the tie-rod end.

(1) Pull out the cotter pin (a).

(2) Remove the castle nut (b).

(3) Using a tie-rod ball joint puller, remove the tie-rod end (c).

Preparation tool:

Tie-rod ball joint puller

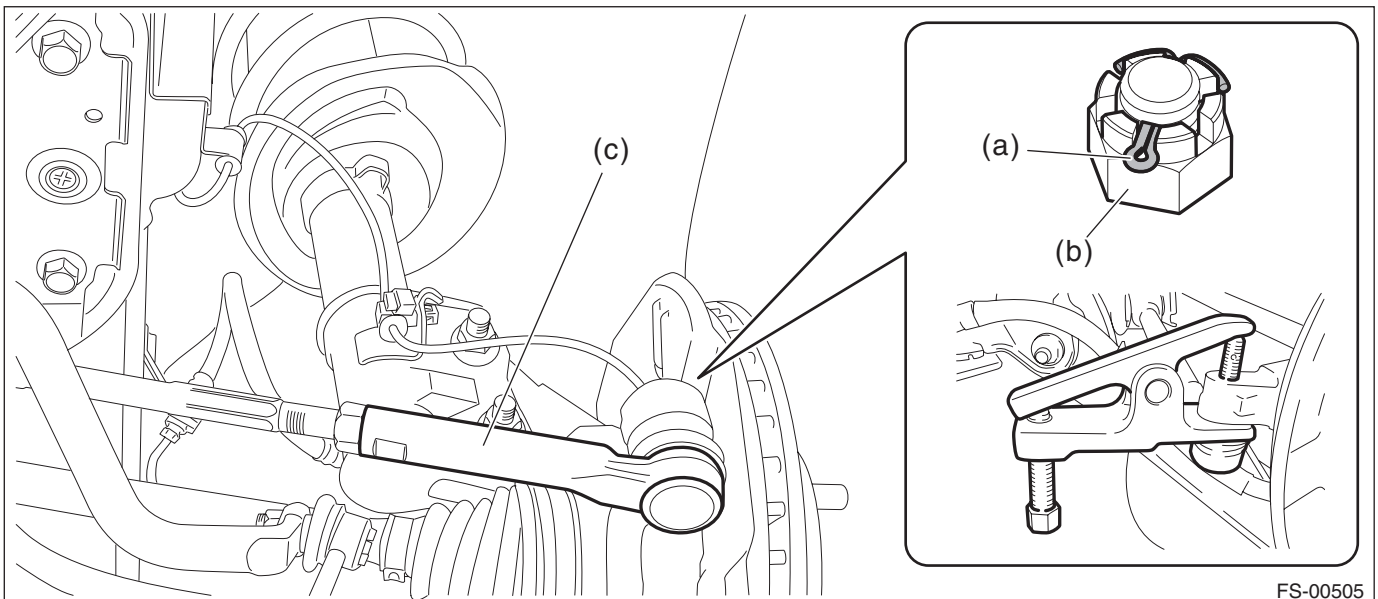

FS-00505

Electric Power Steering Gearbox

POWER ASSISTED SYSTEM (POWER STEERING)

9) Remove the front crossmember support.

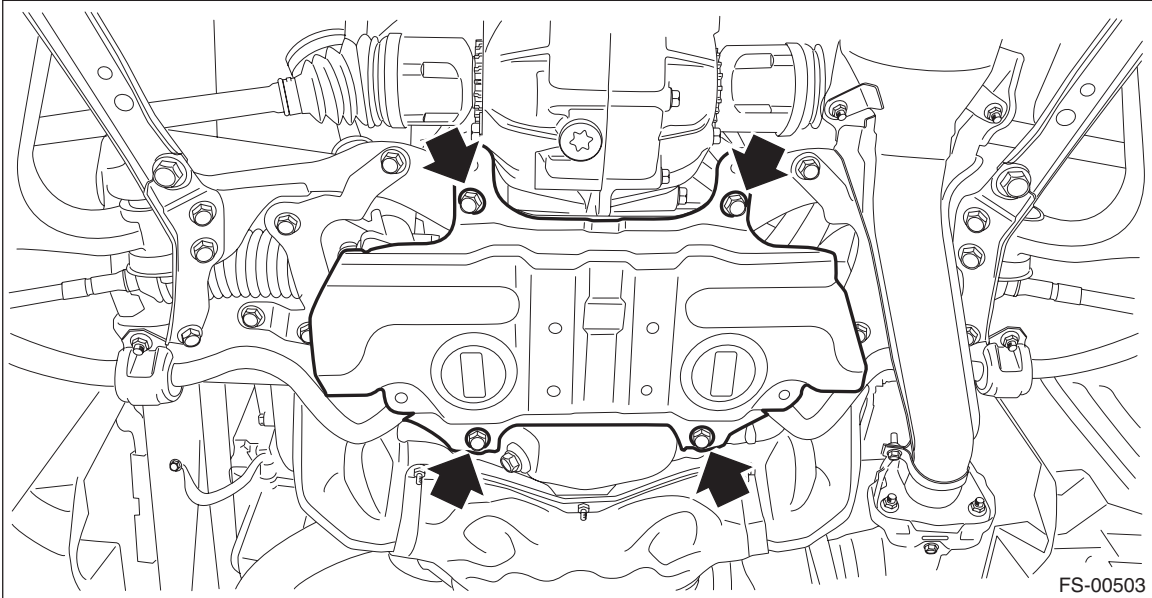

10) Remove the front exhaust pipe assembly. <Ref. to EX(H4DO)-7, REMOVAL, Front Exhaust Pipe.>
11) Remove the support plate - front crossmember (a).

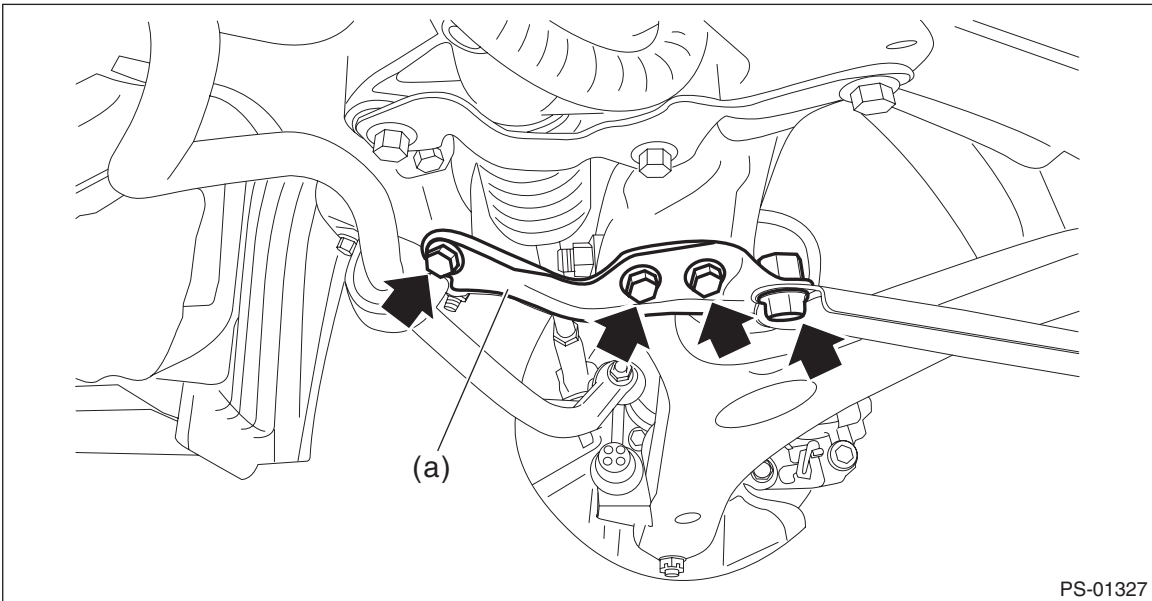

Electric Power Steering Gearbox

POWER ASSISTED SYSTEM (POWER STEERING)

12) Remove the bolts securing the steering gearbox assembly, and remove the stiffener (a) and steering gearbox assembly.

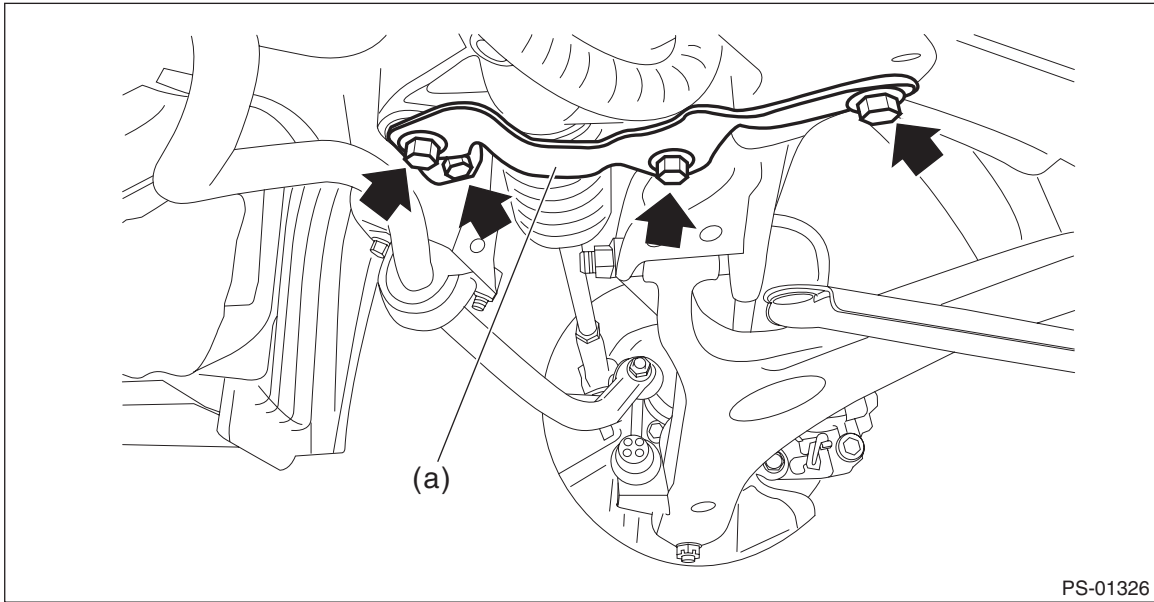

B: INSTALLATION

- 1) Insert the steering gearbox assembly into crossmember, being careful not to damage the boot of the steering gearbox assembly.
- 2) Install the steering gearbox assembly to the crossmember by tightening the bolts through the stiffener (a) to the specified torque.

Tightening torque:

60 N·m (6.12 kgf·m, 44.3 ft·lb)

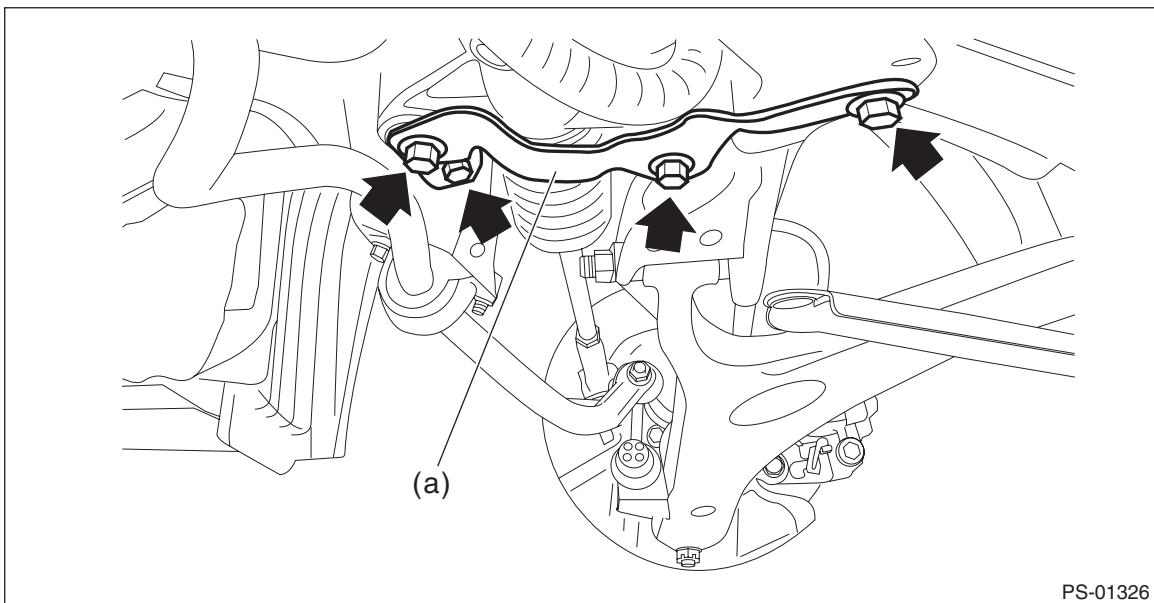

3) Install the universal joint assembly - steering. <Ref. to PS-14, INSTALLATION, Universal Joint.>

CAUTION:

Tighten the bolts of the universal joint assembly - steering in the order of steering gearbox side and column shaft side.

Electric Power Steering Gearbox

POWER ASSISTED SYSTEM (POWER STEERING)

4) Install the support plate - front crossmember (a).

Tightening torque:

Support plate - front crossmember: 60 N·m (6.12 kgf·m, 44.3 ft·lb)

Front support: 100 N·m (10.20 kgf·m, 73.8 ft·lb)

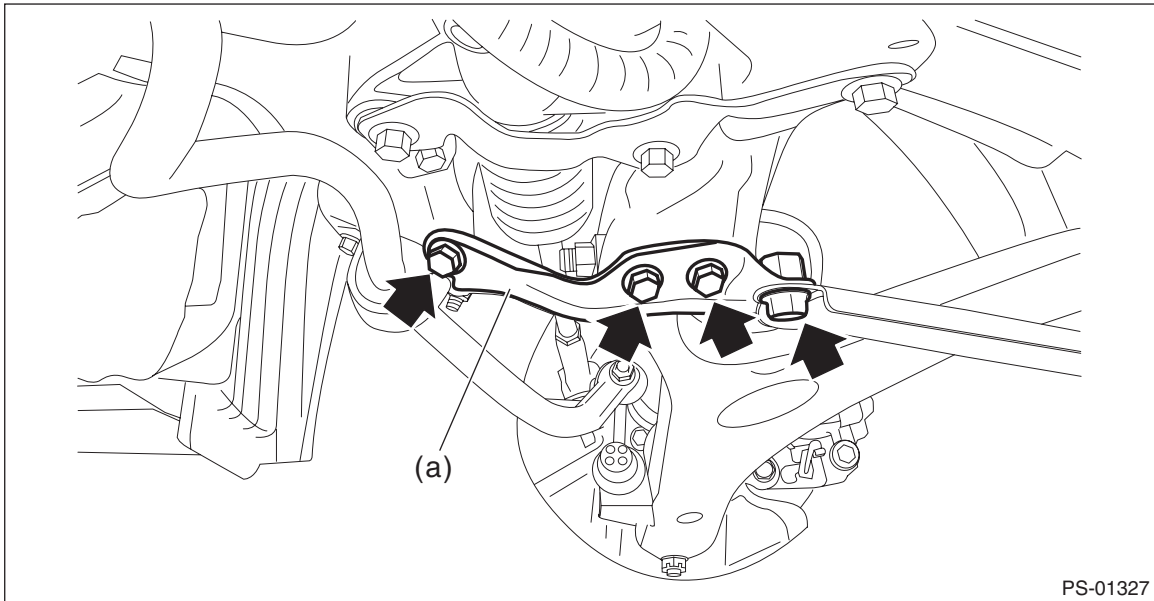

PS-01327

5) Connect the tie-rod ends and knuckle arm.

(1) Connect the tie-rod end (a) to the housing assembly - front axle.

(2) Tighten the castle nuts (b) to the specified torque.

CAUTION:

During connection, do not hit the cap at bottom of tie-rod end with a hammer.

Castle nut tightening torque:

27 N·m (2.75 kgf·m, 19.9 ft·lb)

(3) Tighten within the range of 60° so that the cotter pin hole and cutout portion of the castle nut (b) are aligned.

(4) Insert the cotter pin (c), and bend the tip of the pin to fix it.

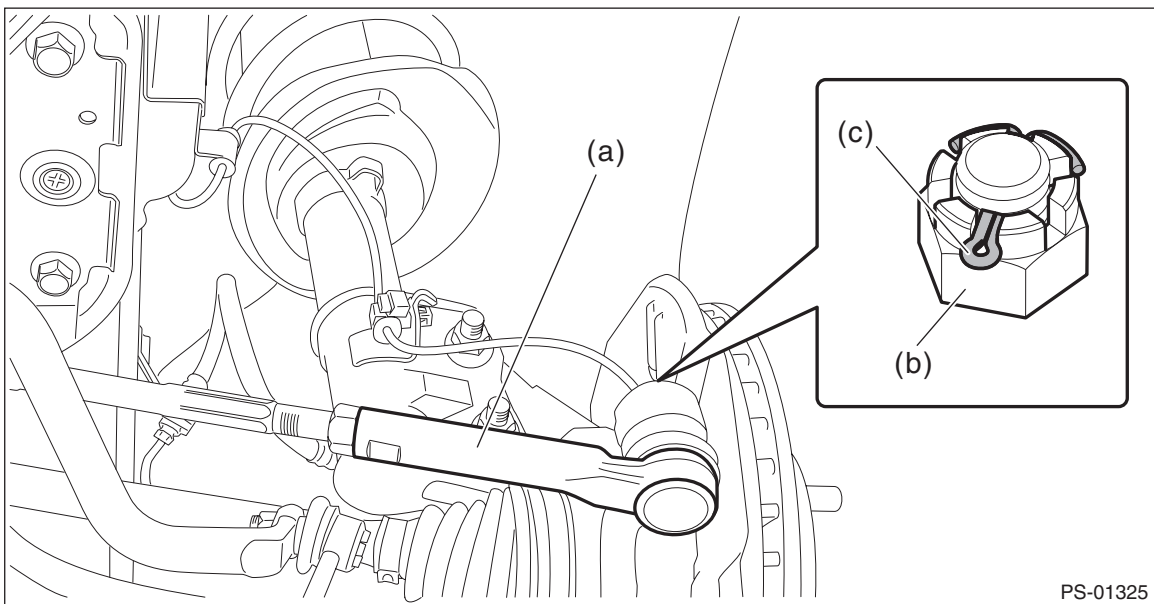

PS-01325

Electric Power Steering Gearbox

POWER ASSISTED SYSTEM (POWER STEERING)

6) Install the front crossmember - support.

Tightening torque:

60 N·m (6.12 kgf-m, 44.3 ft-lb)

7) Install the front exhaust pipe assembly. <Ref. to EX(H4DO)-10, INSTALLATION, Front Exhaust Pipe.>

8) Install the under cover - front. <Ref. to EI-27, INSTALLATION, Front Under Cover.>

9) Install the front wheels.

10) Lower the vehicle.

11) Tighten the wheel nuts to the specified torque.

Tightening torque:

120 N·m (12.24 kgf-m, 88.5 ft-lb)

12) Connect the power steering control module harness connector.

13) Connect the battery ground terminal.

CAUTION:

When the wheel alignment has been adjusted, perform the adjustment of the steering angle sensor. <Ref. to VDC-19, ADJUSTMENT, VDC Control Module and Hydraulic Control Unit (VDCCM&H/U).>

14) After adjusting toe-in and steering angle, tighten the lock nut on tie-rod end.

Tightening torque:

85 N·m (8.67 kgf-m, 62.7 ft-lb)

NOTE:

When adjusting toe-in, hold the boot - steering gearbox as shown to prevent it from being rotated or twisted. If it becomes twisted, straighten it.

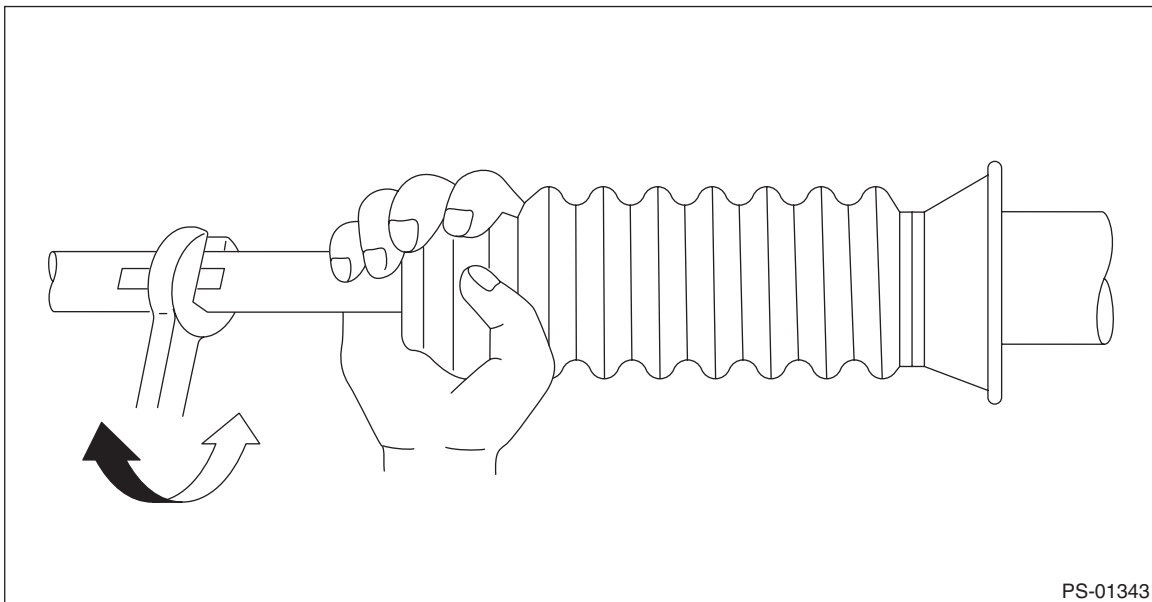

PS-01343

Electric Power Steering Gearbox

POWER ASSISTED SYSTEM (POWER STEERING)

C: DISASSEMBLY

CAUTION:

- Nut for fixing the rack is on the driver's side only. When removing the tie-rod on the passenger's side, turn over the boot - steering gearbox on the driver's side, and fix the rack during operation.

- When fixing the steering gearbox assembly in a vise, apply a wooden piece on the flange portion.

1) Remove the tie-rod end (a) and lock nut (b) from the steering gearbox assembly.

2) Remove the clip - boot tie-rod (c) located outside the boot - steering gearbox using the pliers, and then slide the boot - steering gearbox to the tie-rod end side.

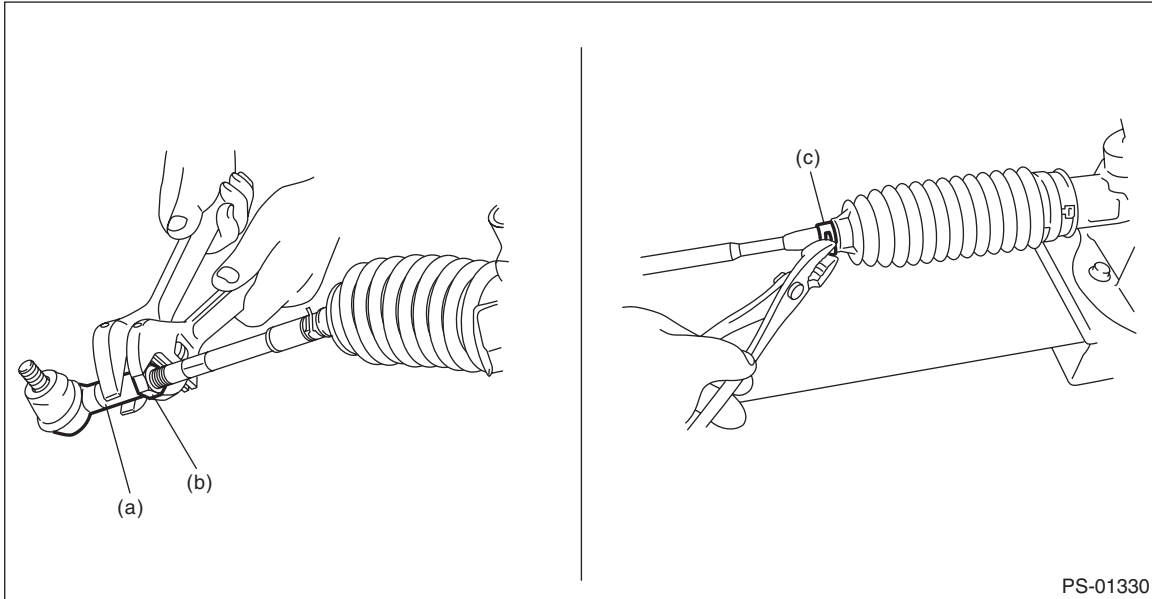

3) Remove the tie-rod (b) from the gearbox assembly.

(1) Using a flat tip screwdriver, remove the band - boot (a) from the boot - steering gearbox.

NOTE:

Replace the boot - steering gearbox or the band - boot (a) if there is damage, cracks or deterioration.

(2) Remove the tie-rod (b).

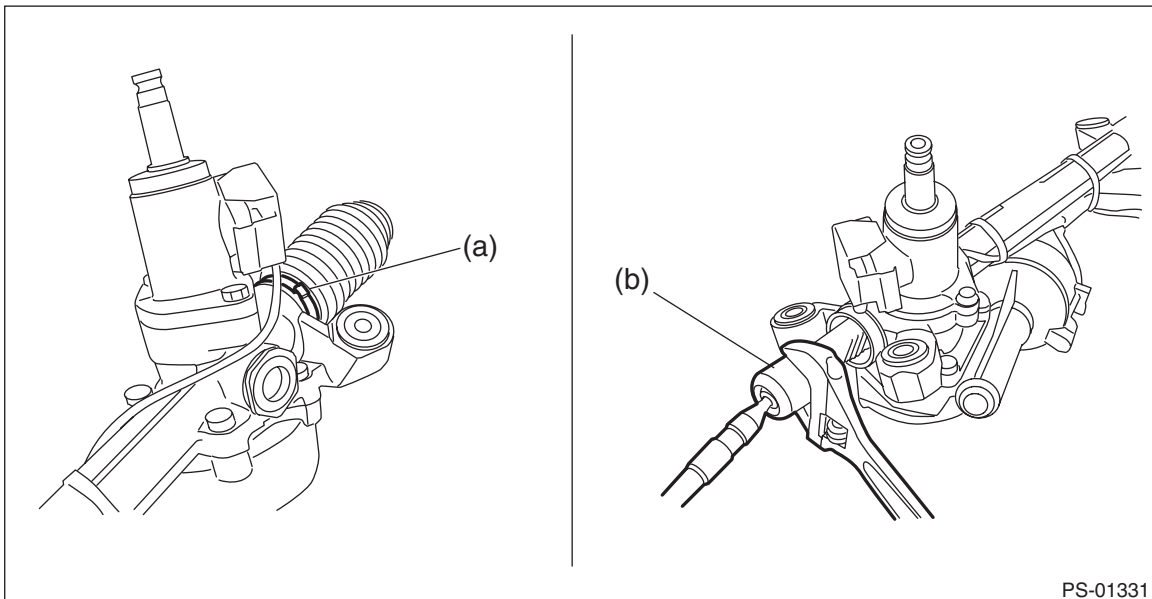

Electric Power Steering Gearbox

POWER ASSISTED SYSTEM (POWER STEERING)

D: ASSEMBLY

1) Install the tie-rod into rack.

Tightening torque:

90 N·m (9.18 kgf·m, 66.4 ft·lb)

NOTE:

Check the mating face of rack and tie-rod for foreign matter such as dust etc.

2) Apply a coat of grease to the tie-rod groove, and then install the boot - steering gearbox to the housing.

NOTE:

Make sure that the boot - steering gearbox is installed without unusual inflation or deflation.

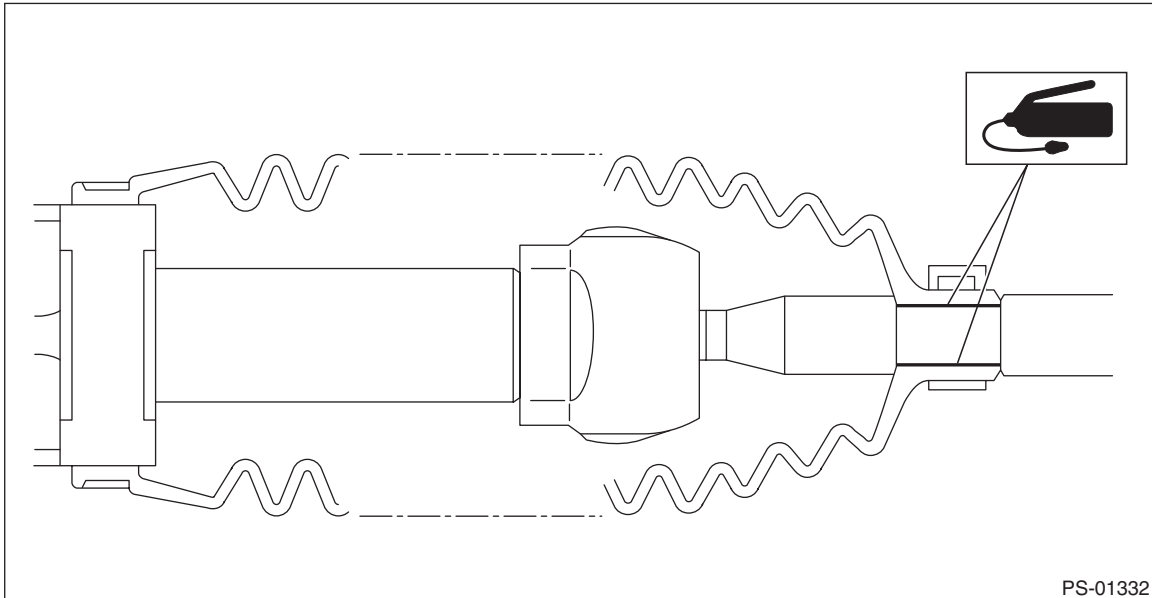

3) Using the boot clamp pliers, crimp the boot so that the clearance (b) of the band - boot (a) crimp portion becomes 2 mm (0.08 in) or less.

NOTE:

Use a new band - boot.

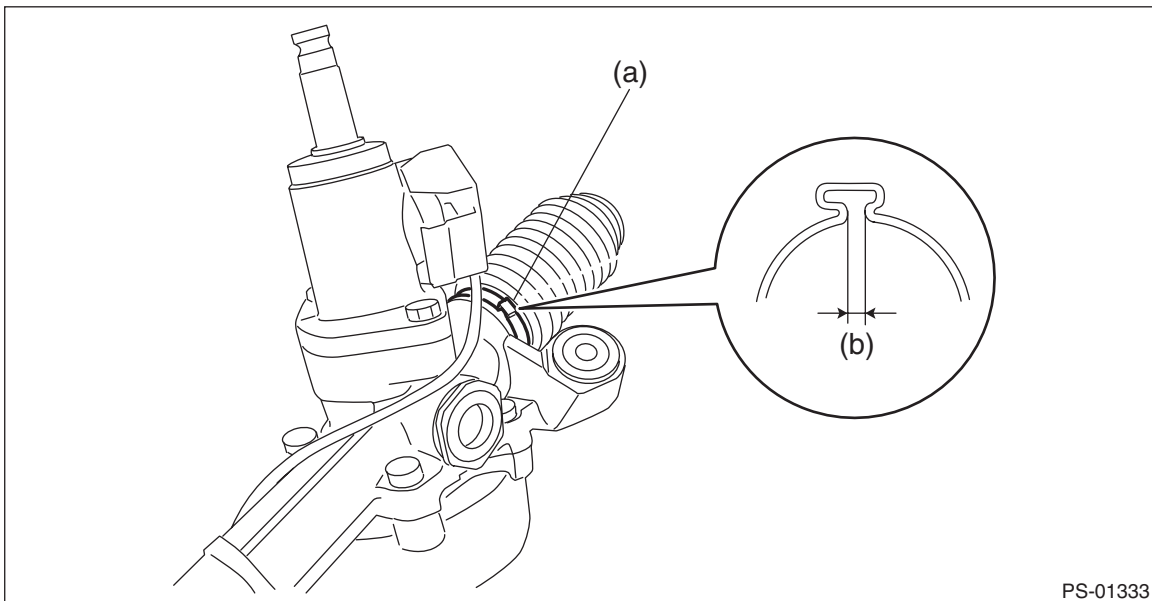

4) Fix the end of the boot - steering gearbox with clip - boot tie-rod (a).

Electric Power Steering Gearbox

POWER ASSISTED SYSTEM (POWER STEERING)

5) After installation, check that the end of the boot - steering gearbox is installed to the groove (b) of the tie-rod.

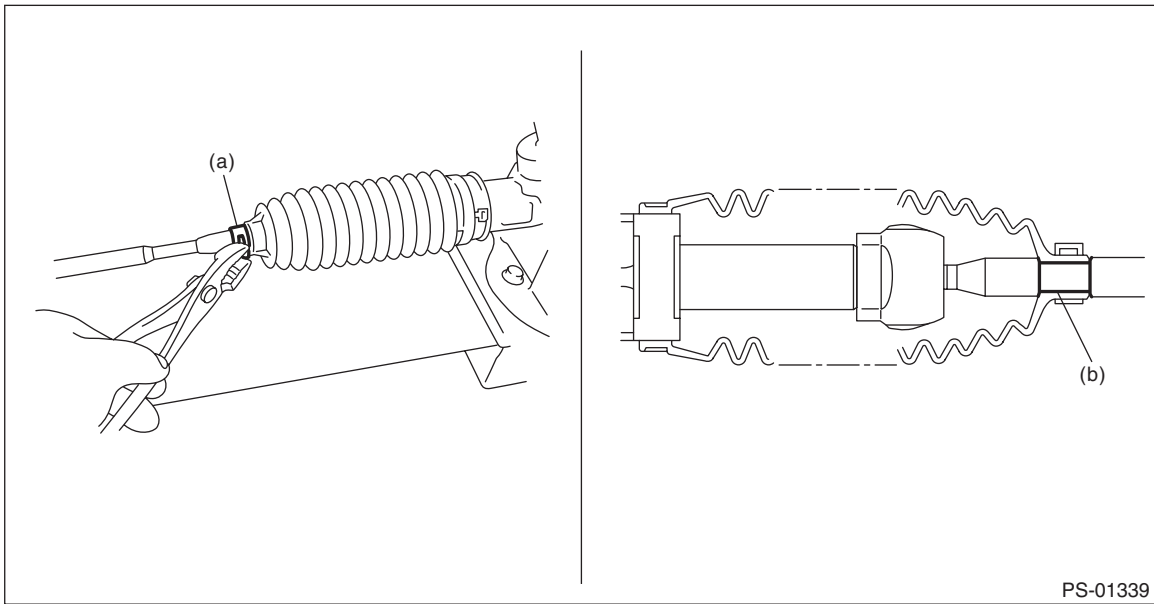

6) If the tie-rod end has been removed, screw in lock nut and tie-rod end to the screwed portion of tie-rod, and tighten the lock nut temporarily in a position as shown in the figure.

Installed tie-rod length L:

33 mm (1.3 in)

7) Inspect the steering gearbox assembly as follows:

1. "A" Holding the tie-rod end, repeat lock to lock several times as quickly as possible.
2. "B" Holding the tie-rod end, turn it slowly at a radius several times as large as possible.
3. Finally, make sure that the boot - steering gearbox is installed in the specified position without inflating.

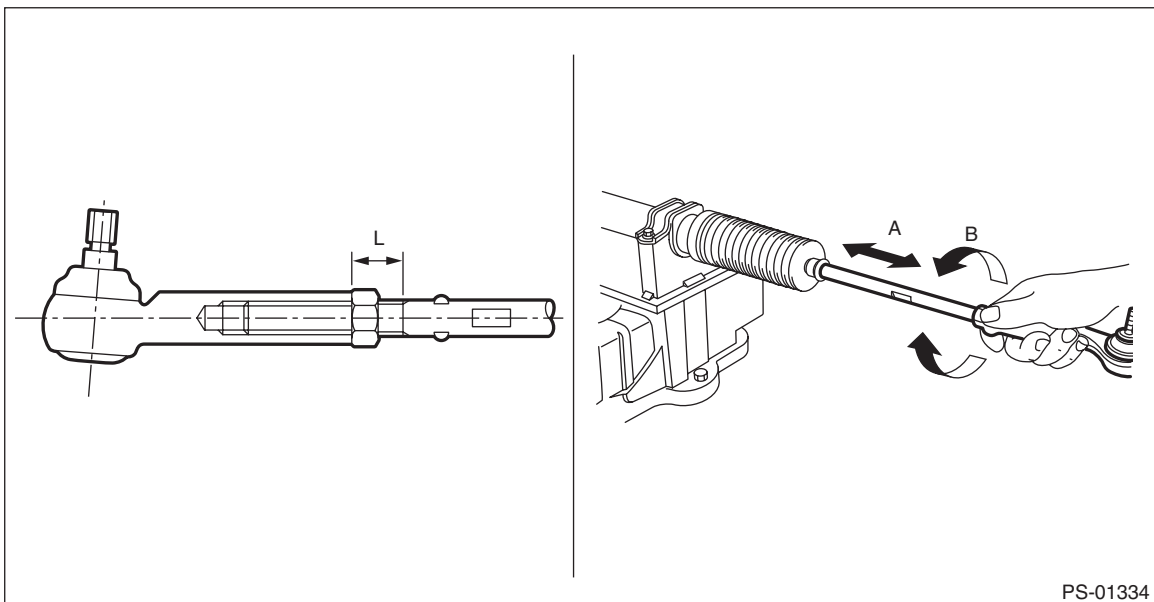

8) Remove the steering gearbox assembly from ST.

Electric Power Steering Gearbox

POWER ASSISTED SYSTEM (POWER STEERING)

E: INSPECTION

1. UNIT INSPECTION

Check components for wear, damage or other faults. Adjust or replace if necessary.

2. LIMIT

Make a measurements as follows. If it exceeds the specified service limits, adjust or replace.

NOTE:

When fixing the steering gearbox assembly in a vise, apply a wooden piece on the flange portion.

Rack shaft sliding resistance (Except for XV model):

Limit: 350 N (36 kgf, 79 lbf) or less

Left/right differential of sliding resistance: 20% or less

Rack shaft sliding resistance (XV model):

Limit: 333 N (34 kgf, 75 lbf) or less

Left/right differential of sliding resistance: 20% or less

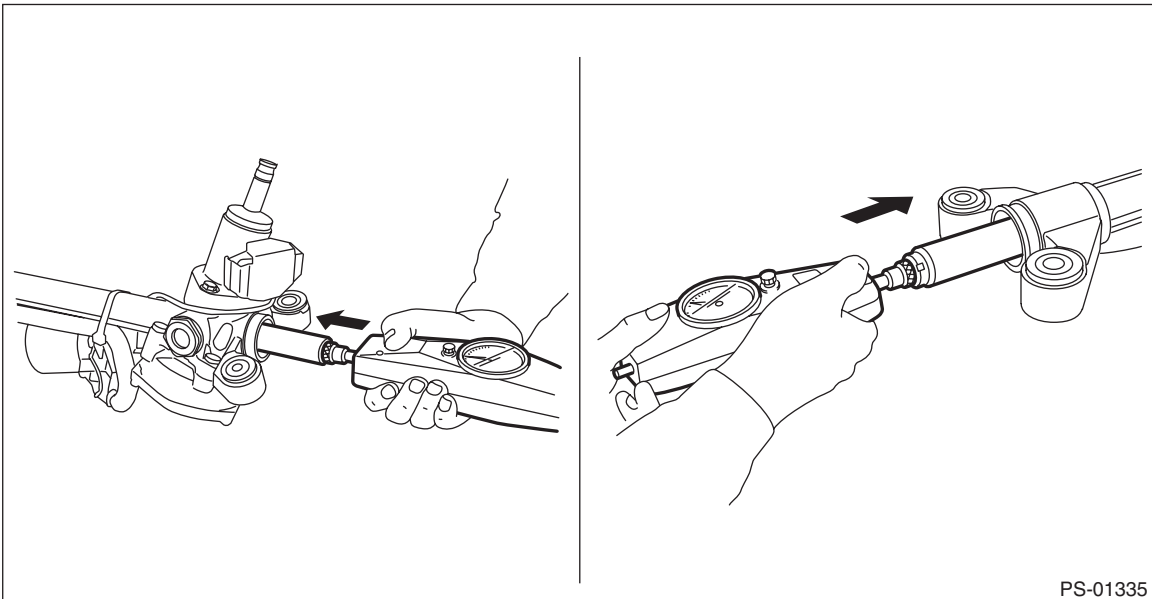

PS-01335

Electric Power Steering Gearbox

POWER ASSISTED SYSTEM (POWER STEERING)

3. RACK SHAFT PLAY IN THE RADIAL DIRECTION

Right-turn steering:

Service limit:

Direction $\leftarrow \rightarrow$: 0.4 mm (0.016 in) or less

Direction $\leftarrow \rightarrow$: 0.6 mm (0.024 in) or less

Left-turn steering:

Service limit:

Direction $\leftarrow \rightarrow$ $\leftarrow \rightarrow$: 0.4 mm (0.016 in) or less

Condition:

L: 5 mm (0.20 in)

P: 98 N (10 kgf, 22 lbf)

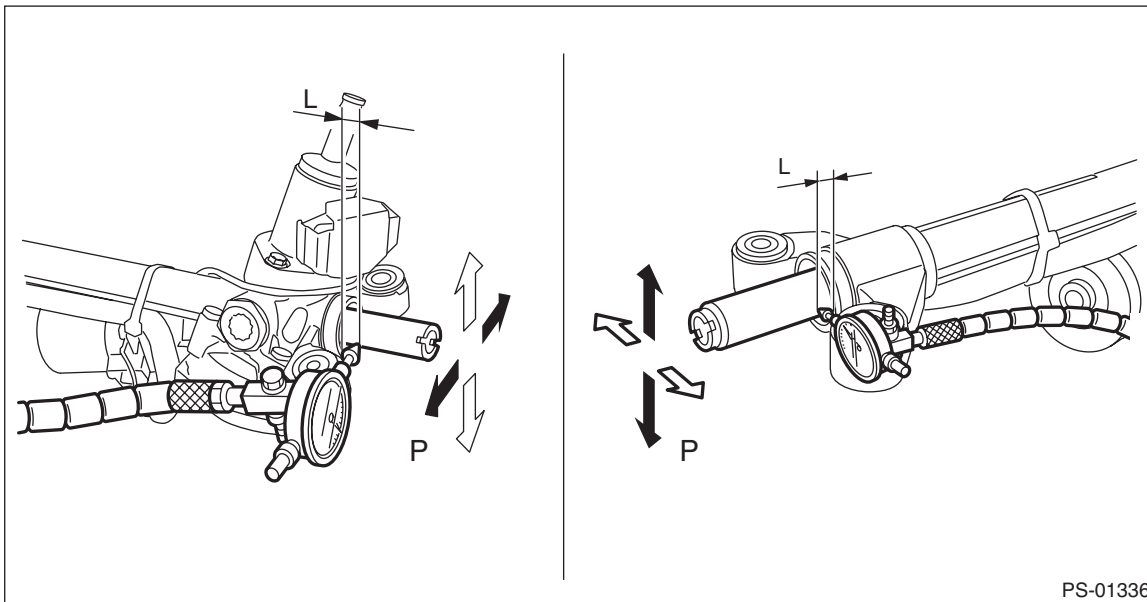

Electric Power Steering Gearbox

POWER ASSISTED SYSTEM (POWER STEERING)

4. INPUT SHAFT PLAY

In radial direction:

Wear limit: 0.18 mm (0.0071 in) or less

Condition: $P = 98\text{ N}$ (10 kgf, 22 lbf)

In axial direction:

Service limit: 0.27 mm (0.0106 in) or less

Condition: $P = 20 - 49\text{ N}$ (2 - 5 kgf, 4 - 11 lbf)

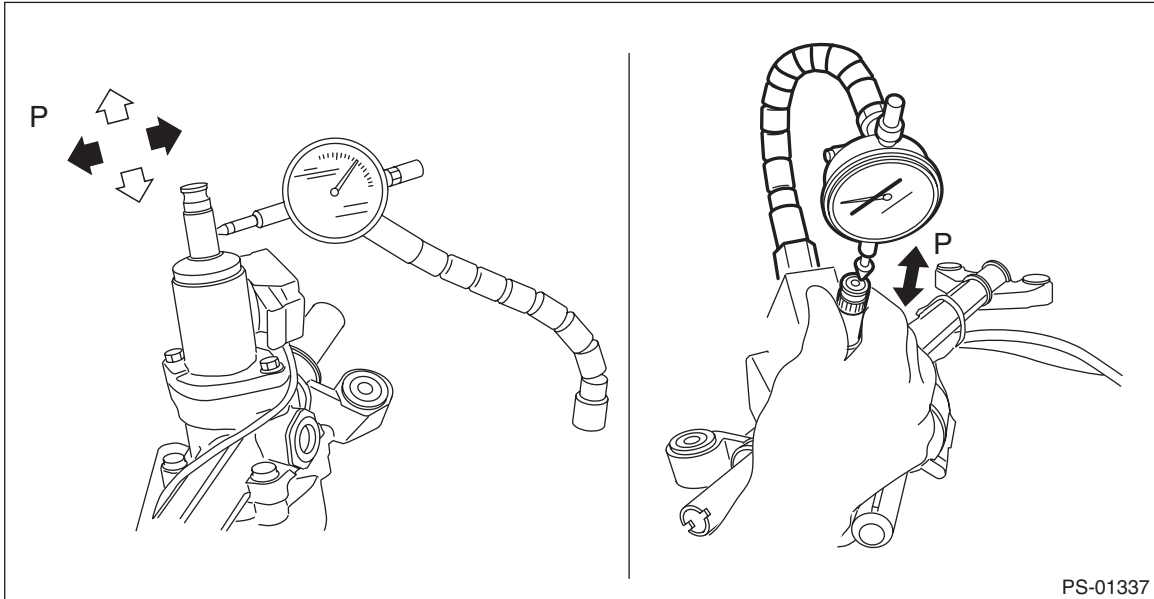

Electric Power Steering Gearbox

POWER ASSISTED SYSTEM (POWER STEERING)

5. TURNING RESISTANCE OF GEARBOX

1) Using the ST, measure the rotational resistance of the steering gearbox assembly.

Preparation tool:

ST: SPANNER (34099PA100)

Service limit (Except for XV model):

Maximum allowable resistance: 18.3 N (1.9 kgf, 4.1 lbf) or less

Difference between right and left rotational resistance: 20% or less

Service limit (XV model):

Maximum allowable resistance: 17.7 N (1.8 kgf, 4.0 lbf) or less

Difference between right and left rotational resistance: 20% or less

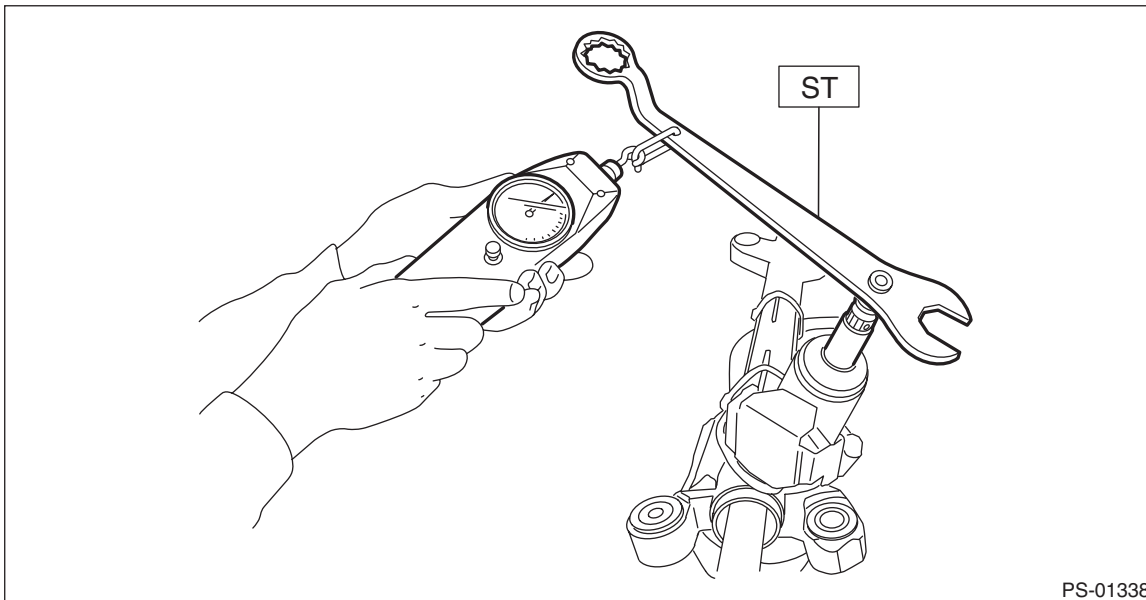

PS-01338

Electric Power Steering Gearbox

POWER ASSISTED SYSTEM (POWER STEERING)

F: ADJUSTMENT

1. GEARBOX BACKLASH ADJUSTMENT

- 1) Remove the steering gearbox assembly. <Ref. to PS-26, REMOVAL, Electric Power Steering Gearbox.>
- 2) Loosen the lock nut and adjusting screw.
- 3) Apply a coat of grease to the sliding surface (B) of the pad - pressure (a) and seating surface (C) of spring - gearbox (b), and then insert the pad - pressure (a) into steering body.
- 4) Charge the adjusting screw (c) with grease (D), and then insert the spring - gearbox (b) into adjusting screw. Then install on the steering body.

Grease:

Multemp AC-P

- 5) Apply liquid gasket to 1/3 or more (A) of entire perimeter of adjusting screw thread (c).

Liquid gasket:

THREE BOND TB-1111B

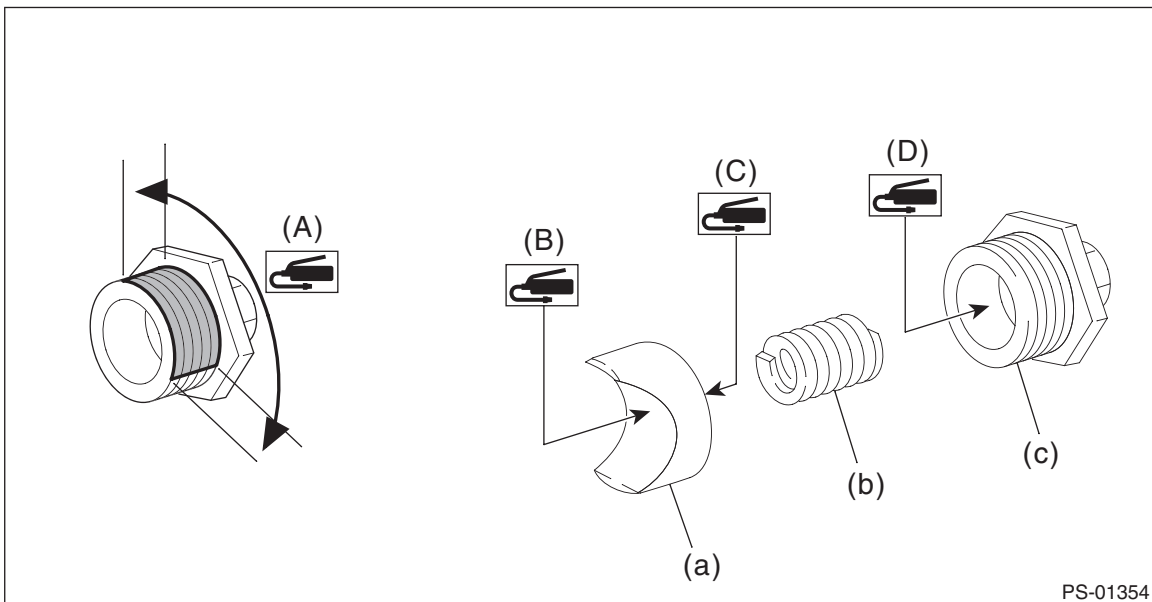

- 6) Tighten the adjusting screw to 9.8 N·m (1.0 kgf-m, 7.2 ft-lb), then loosen it.
- 7) Tighten the adjusting screw to 6 N·m (0.6 kgf-m, 4.4 ft-lb).
- 8) Loosen the adjusting screw by 20°.
- 9) While fixing the adjusting screw, tighten the lock nuts.

Tightening torque:

49.4 N·m (5.04 kgf-m, 36.4 ft-lb)

Electric Power Steering Gearbox

POWER ASSISTED SYSTEM (POWER STEERING)

2. FRONT WHEEL ALIGNMENT ADJUSTMENT

- 1) Adjust the front toe. <Ref. to FS-15, FRONT WHEEL TOE-IN, ADJUSTMENT, Wheel Alignment.>
- 2) Check the steering angle of the wheels.

Standard of steering angle:

| Model | Except for XV model | XV model |
|-------------|--------------------------------|--------------------------------|
| Inner wheel | $38.3^{\circ} \pm 1.5^{\circ}$ | $38.5^{\circ} \pm 1.5^{\circ}$ |
| Outer wheel | $33.7^{\circ} \pm 1.5^{\circ}$ | $34.0^{\circ} \pm 1.5^{\circ}$ |

- 3) When the steering wheel is in the following condition, perform the steering wheel installation over again.
 - When wheels are set in the straight ahead position, the steering wheel spokes are not horizontal.
 - Error is more than 5° on the periphery of the steering wheel.

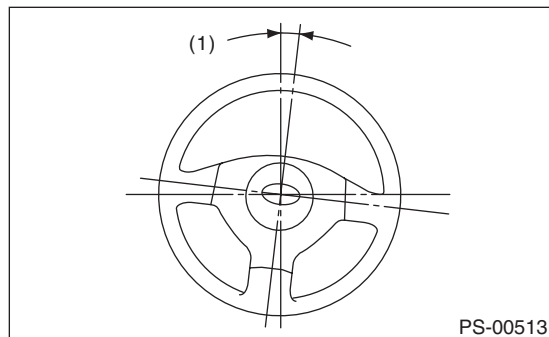

(1) 5° or less

- 4) If the steering wheel spokes are not horizontal with vehicle set in the straight ahead position after this adjustment, correct it by turning the right and left tie-rods in the opposite direction from each other by the same angle. Also check that there are no abnormal steering force, failure of the steering wheel to return or other faults.