

6. Crankshaft Position Sensor

A: REMOVAL

- 1) Disconnect the ground cable from battery.

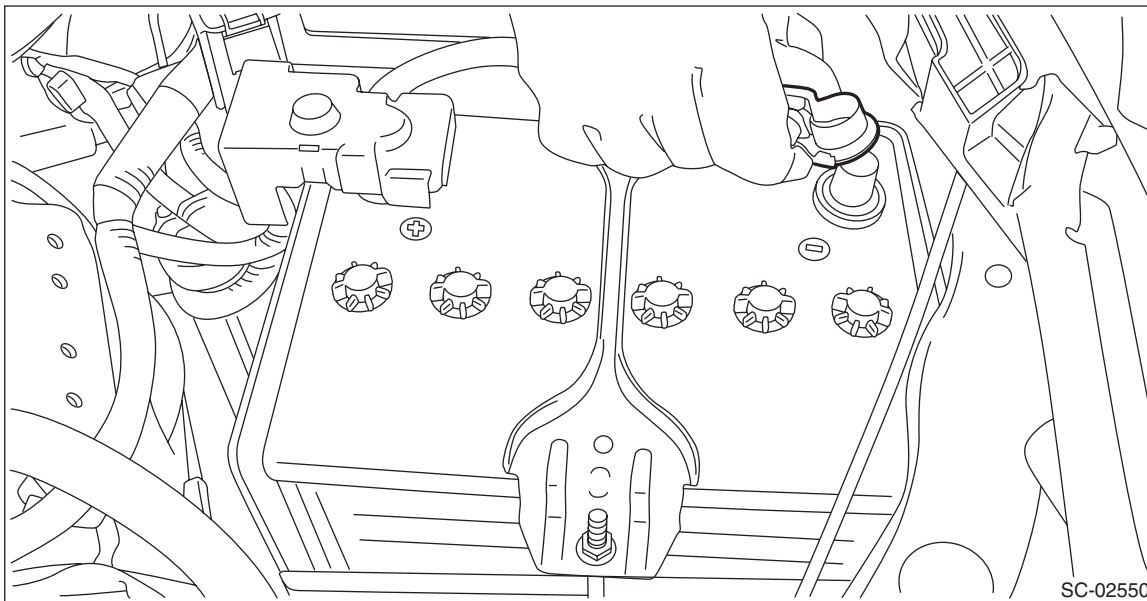

- 2) Remove the clip (A) from the air intake boot.
- 3) Loosen the clamp (B) connecting the air intake boot and air cleaner case (rear).
- 4) Loosen the clamp (C) which connects the air intake boot and throttle body.

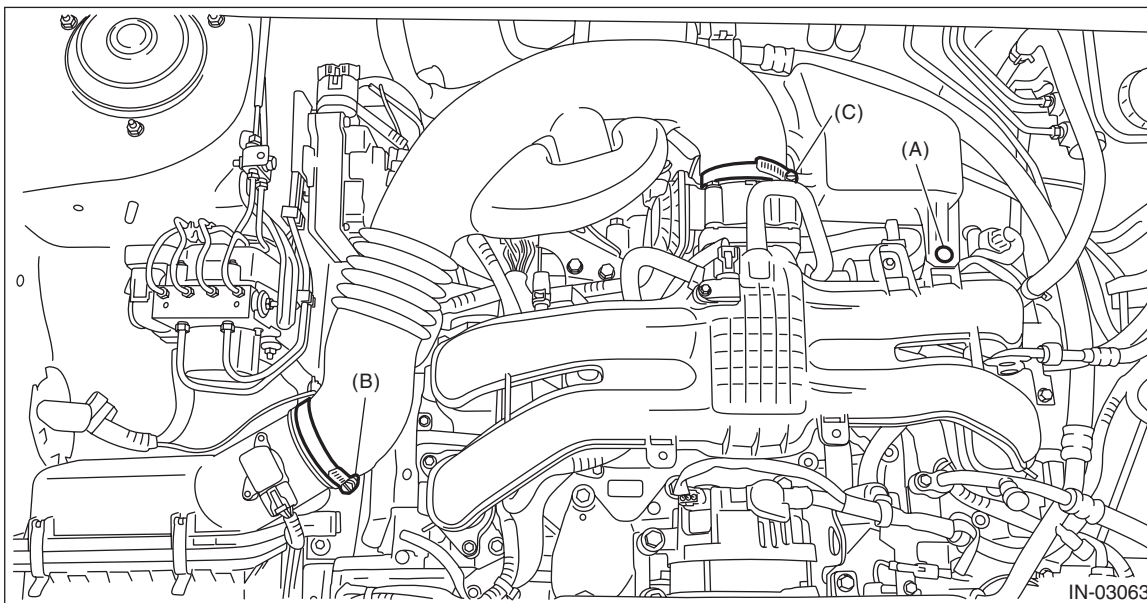

Crankshaft Position Sensor

FUEL INJECTION (FUEL SYSTEMS)

5) Remove the air intake boot from the throttle body, and move the air intake boot to the left side wheel apron.

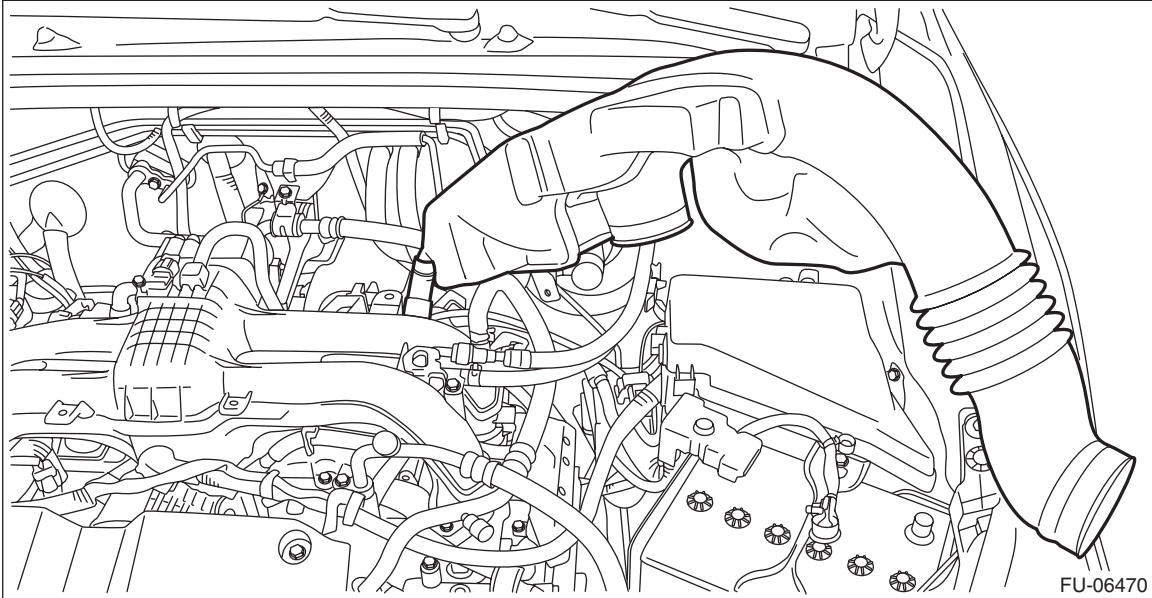

6) Disconnect the connector (A) from the crankshaft position sensor, and remove the crankshaft position sensor from the cylinder block.

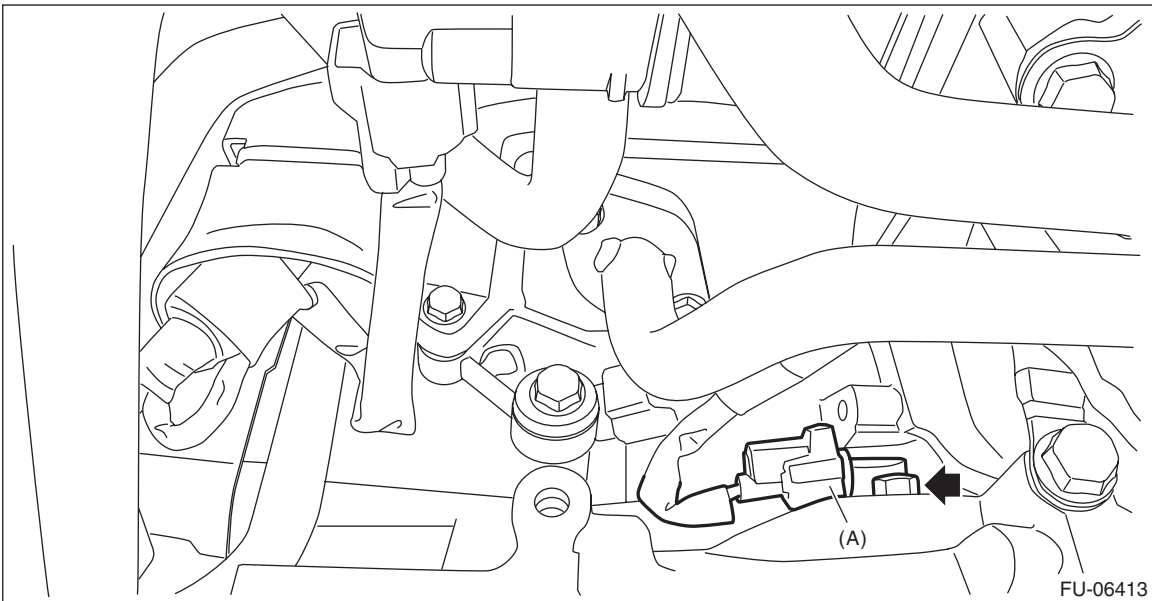

B: INSTALLATION

Install in the reverse order of removal.

Tightening torque:

6.4 N·m (0.7 kgf-m, 4.7 ft-lb)

Crankshaft Position Sensor

FUEL INJECTION (FUEL SYSTEMS)

C: INSPECTION

1. CRANKSHAFT POSITION SENSOR (METHOD WITH CIRCUIT TESTER)

Measure the resistance between crankshaft position sensor terminals.

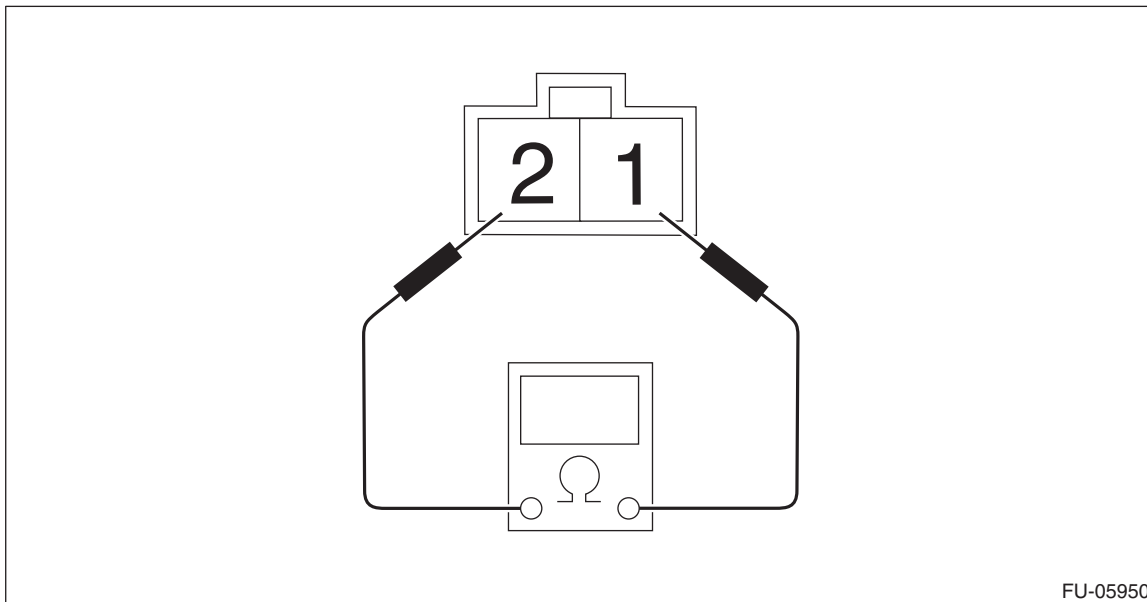

Terminal No.	Standard
1 and 2	$2.04 \pm 0.204 \text{ k}\Omega$

Crankshaft Position Sensor

FUEL INJECTION (FUEL SYSTEMS)

2. CRANKSHAFT POSITION SENSOR (METHOD WITH OSCILLOSCOPE)

- 1) Prepare an oscilloscope.
- 2) Remove the back panel - pocket. <Ref. to EI-67, REMOVAL, Glove Box.>
- 3) Connect the probe to ECM connector.

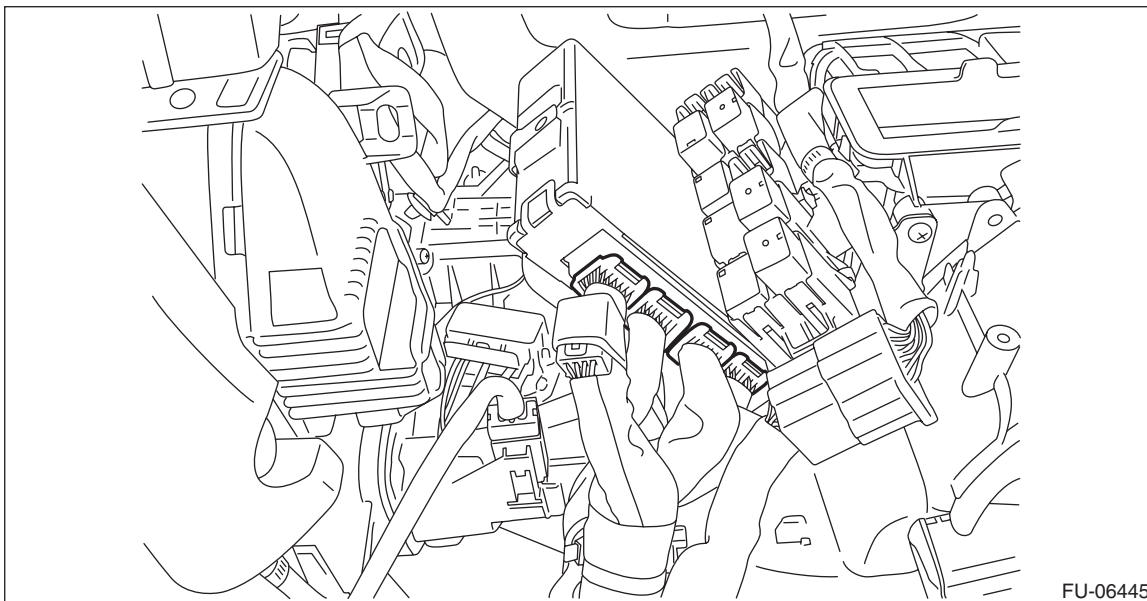

FU-06445

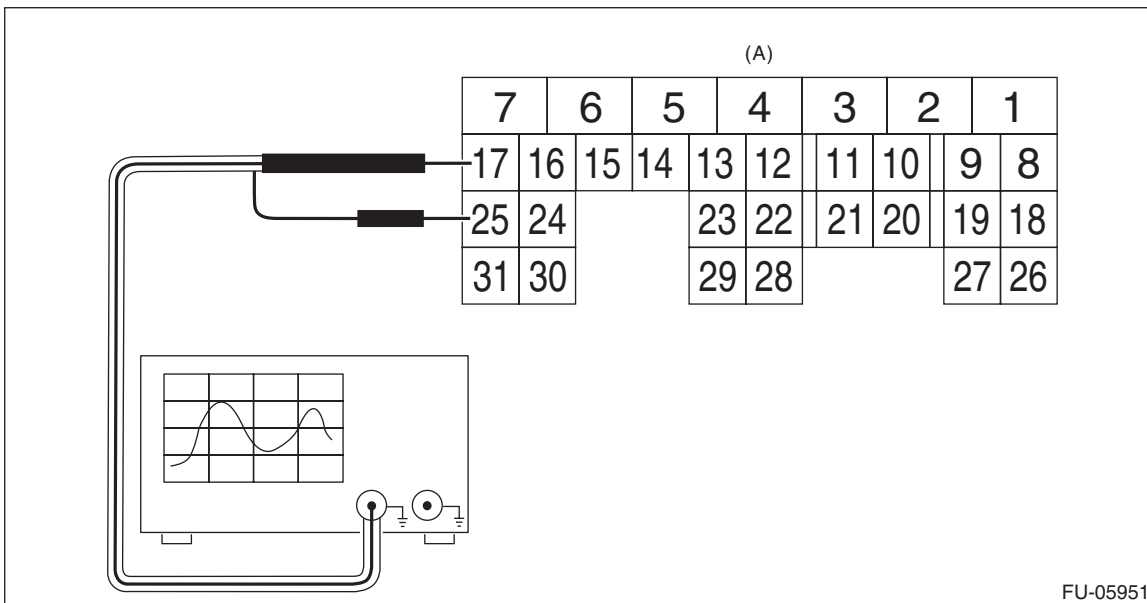

FU-05951

(A) To ECM connector

Terminal No.	Probe
17	+
25	-

- 4) Start the engine and let it idle.

Crankshaft Position Sensor

FUEL INJECTION (FUEL SYSTEMS)

5) Check the pattern is the same as the waveform and voltage shown below.

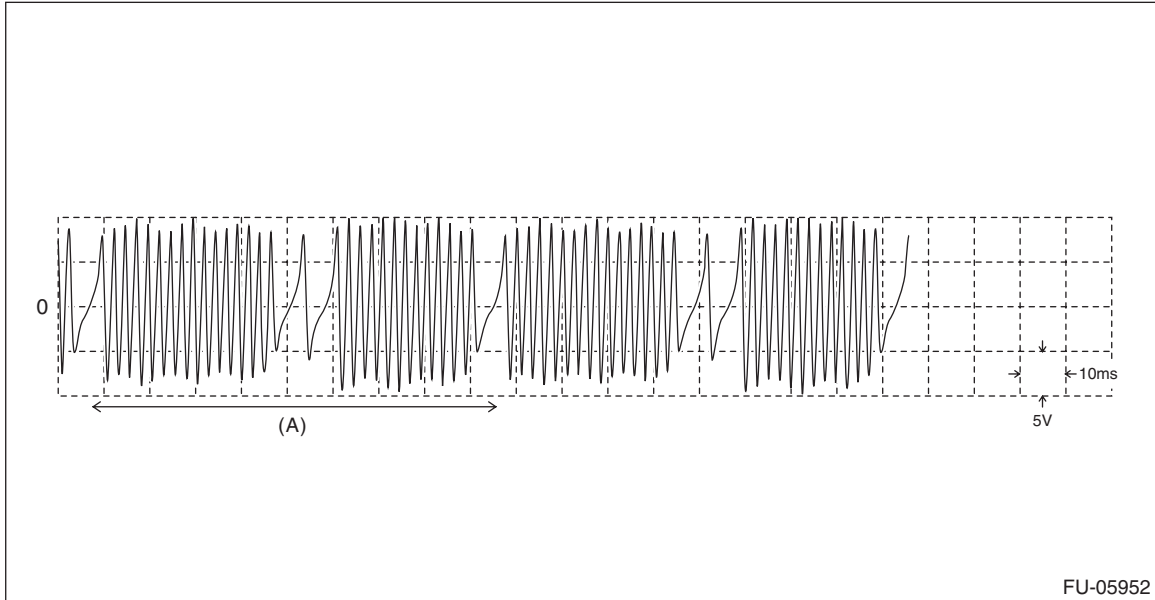

(A) One crankshaft rotation

6) After inspection, install the related parts in the reverse order of removal.

3. OTHER INSPECTIONS

Check that the crankshaft position sensor has no deformation, cracks or other damages.