

12. Mass Air Flow and Intake Air Temperature Sensor

A: REMOVAL

1) Disconnect the ground cable from battery.

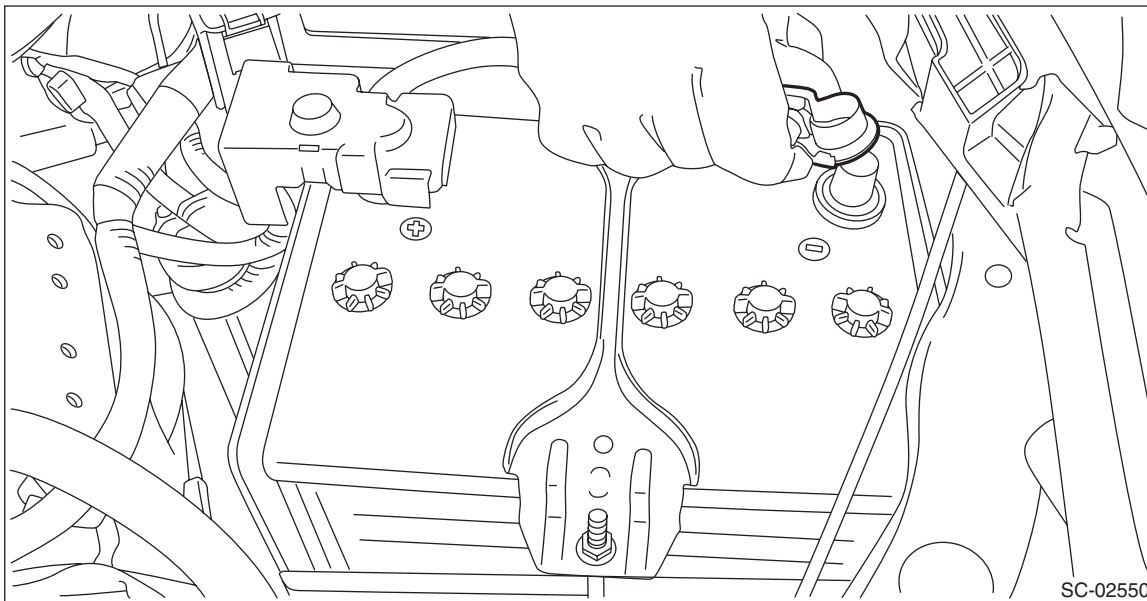

2) Disconnect the connector (A) from the mass air flow and intake air temperature sensor, and remove the mass air flow and intake air temperature sensor.

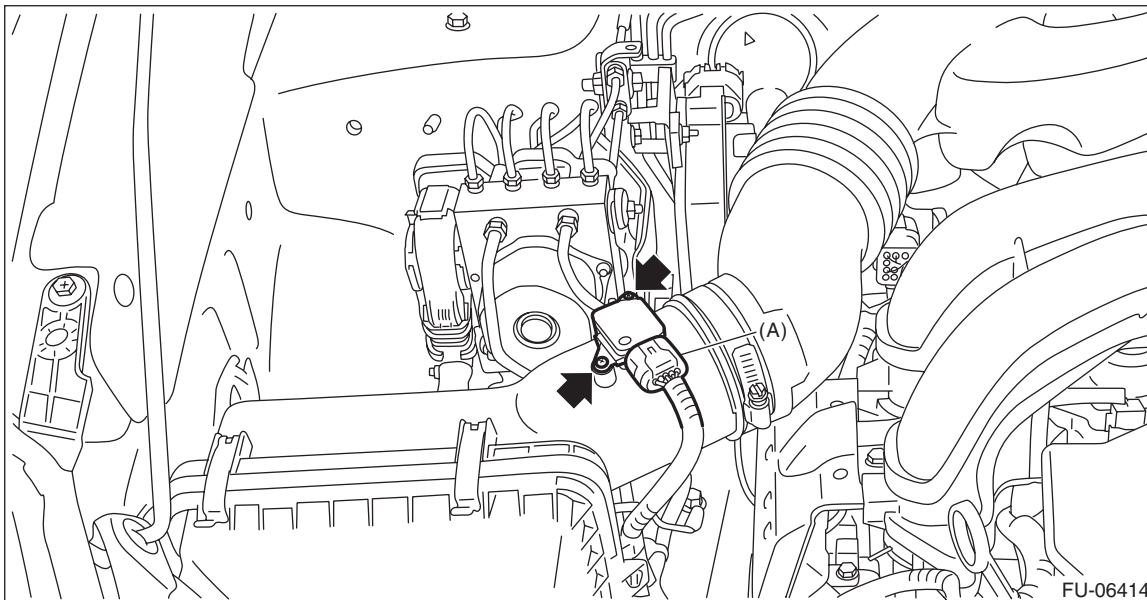

B: INSTALLATION

Install in the reverse order of removal.

Tightening torque:

1 N·m (0.1 kgf·m, 0.7 ft·lb)

Mass Air Flow and Intake Air Temperature Sensor

FUEL INJECTION (FUEL SYSTEMS)

C: INSPECTION

1. CHECK THE MASS AIR FLOW SENSOR UNIT

1) Connect the battery positive terminal to terminal No. 3 and the battery ground terminal to terminal No. 4, the circuit tester positive terminal to terminal No. 5 and the circuit tester ground terminal to terminal No. 4.

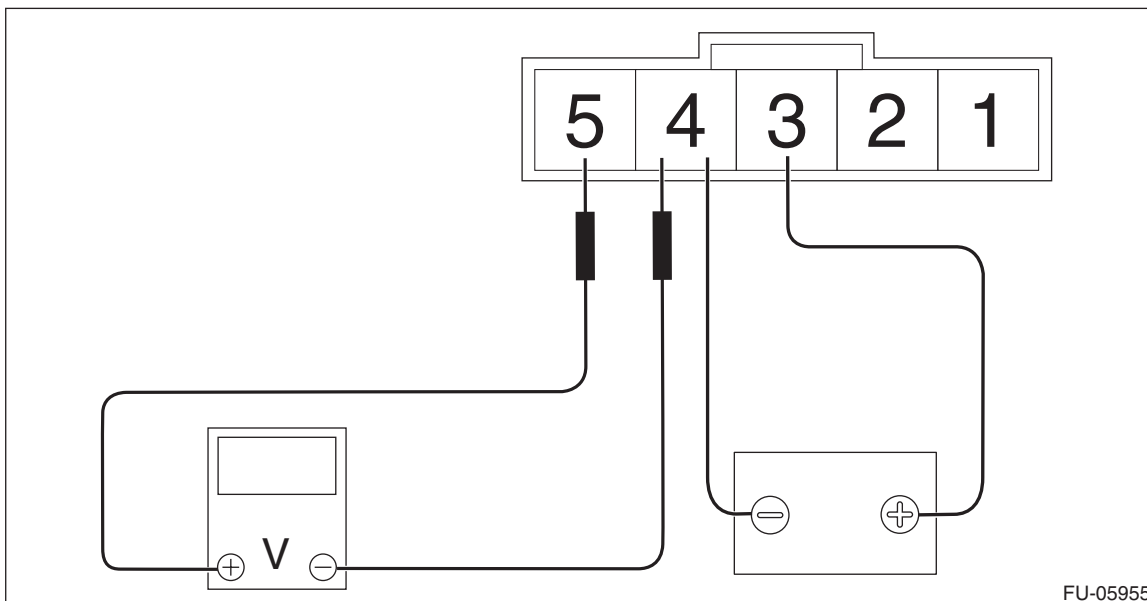

2) Check the voltage changes when air is blown to the mass air flow sensor unit in arrow direction.

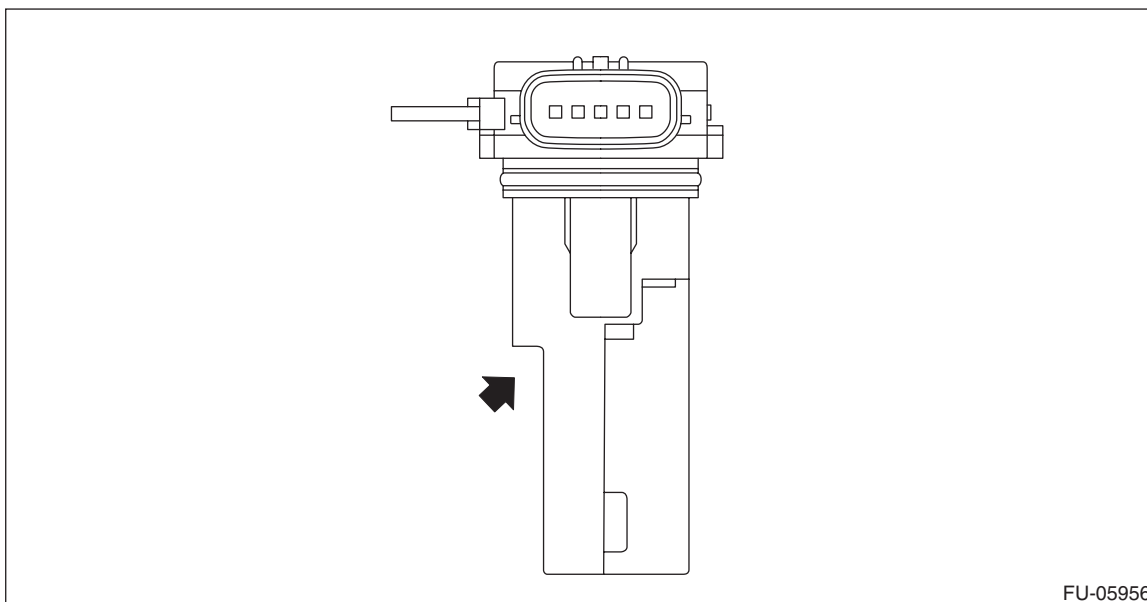

Mass Air Flow and Intake Air Temperature Sensor

FUEL INJECTION (FUEL SYSTEMS)

2. CHECK THE INTAKE AIR TEMPERATURE SENSOR UNIT

Measure the resistance between intake air temperature sensor terminals.

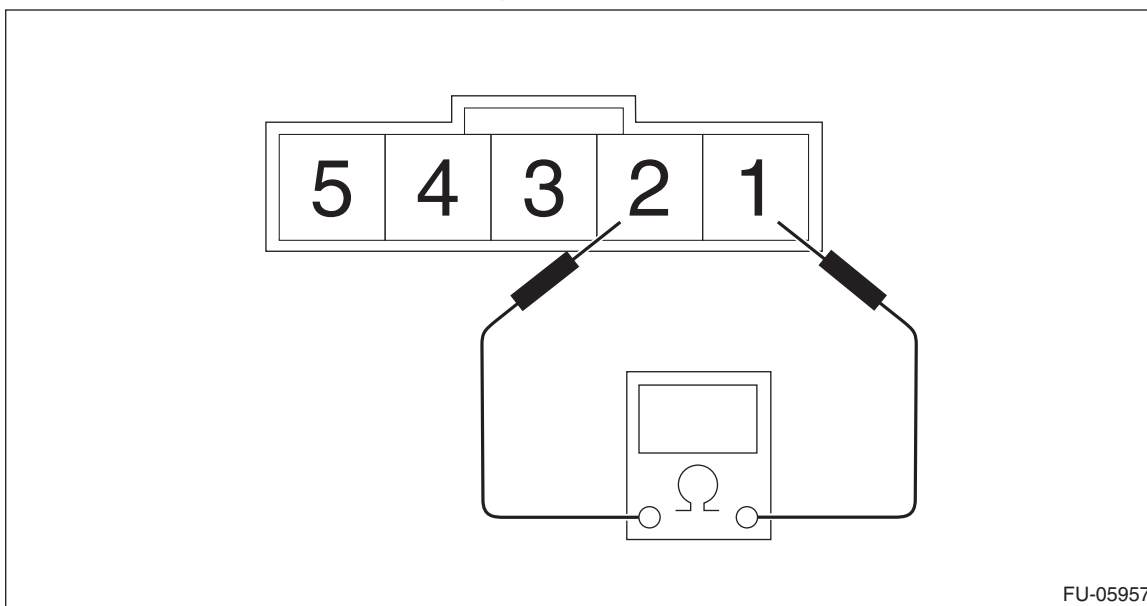

Temperature	Terminal No.	Standard
-20°C (-4°F)	1 and 2	16.0±2.4 kΩ
20°C (68°F)		2.45±0.24 kΩ
60°C (140°F)		0.58±0.087 kΩ

3. OTHER INSPECTIONS

- 1) Check that the mass air flow and intake air temperature sensor has no deformation, cracks or other damages.
- 2) Check that the mass air flow and intake air temperature sensor has no dirt.