

General Description

LIGHTING SYSTEM

1. General Description

A: SPECIFICATION

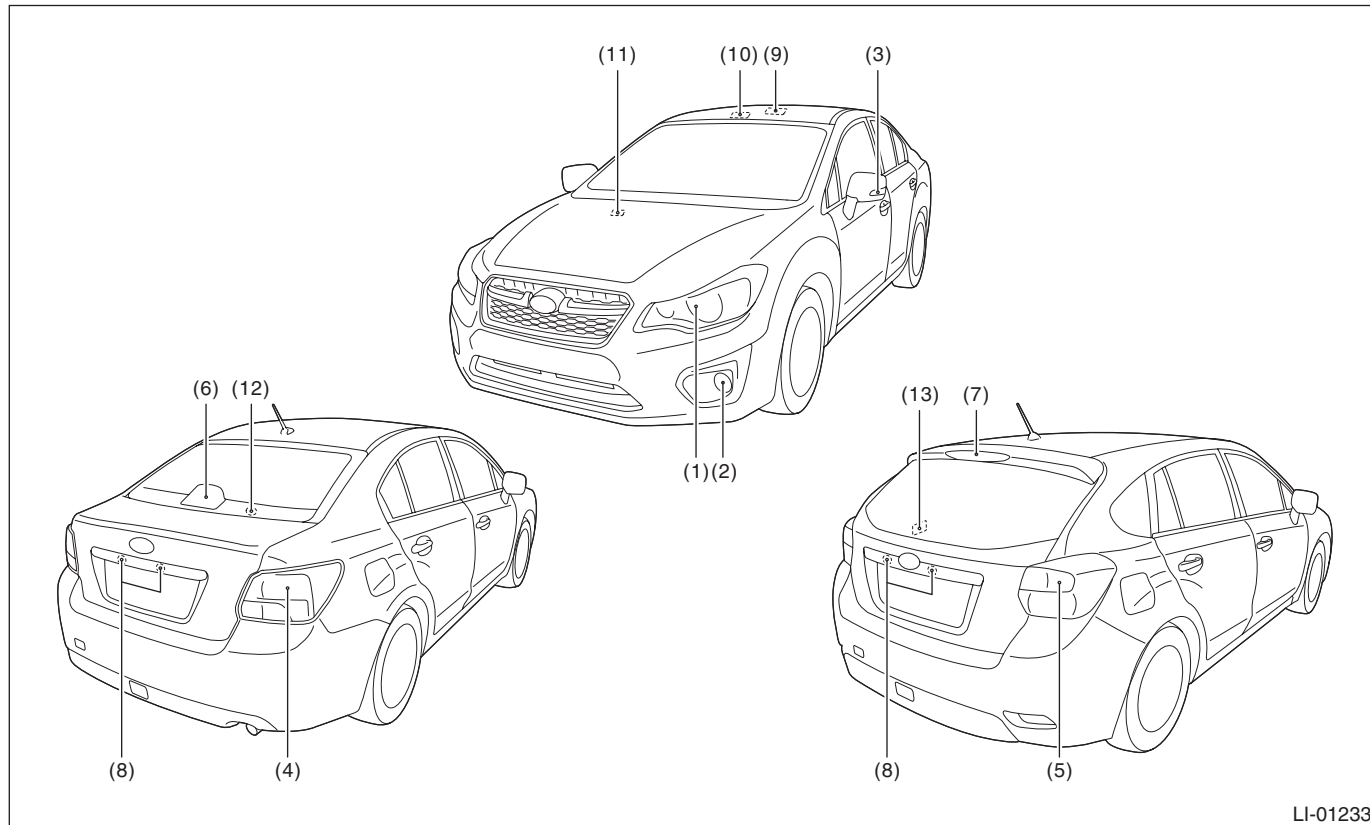

LI-01233

(1)	Headlight	Low beam (Halogen type)	12 V — 55 W
		Low beam (HID type)	12 V — 35 W
		High beam	12 V — 60 W
		Front turn signal light	12 V — 21 W
		Parking light	12 V — 5 W
		Side marker light	12 V — 5 W
(2)	Front fog light		12 V — 24 W
(3)	Side turn signal light		12 V — 1.1 W (LED)
(4)	Rear combination light (4 door model)	Tail & side marker/stop light	12 V — 5 / 21 W
		Turn signal light	12 V — 21 W
		Back-up light	12 V — 16 W
(5)	Rear combination light (5 door model/XV model)	Tail/stop light	12 V — 5 / 21 W
		Back-up light	12 V — 16 W
		Turn signal light	12 V — 21 W
		Side marker light	12 V — 5 W
(6)	High-mounted stop light (4 door model)		12 V — 21 W
(7)	High-mounted stop light (5 door model/XV model)		12 V — 2.1 W (LED)
(8)	License plate light		12 V — 5 W
(9)	Room light		12 V — 8 W
(10)	Spot map light		12 V — 8 W
(11)	Glove box light		12 V — 1.4 W
(12)	Trunk room light (4 door model)		12 V — 5 W
(13)	Luggage room light (5 door model/XV model)		12 V — 5 W

B: CAUTION

- Before disassembling or reassembling parts, always disconnect the battery ground cable from battery. When replacing the audio, control module and other parts provided with memory functions, record the memory contents before disconnecting the battery ground cable. Otherwise, the memory is cleared.
- Reassemble the parts in the reverse order of disassembly procedure unless otherwise indicated.
- Connect the connectors securely during reassembly.
- After reassembly, make sure that the each component operates normally.
- Yellow connectors and harnesses with yellow tapes around them are the connectors and harnesses for the airbag system. Using a tester above such circuits may cause malfunction of airbag system. Follow the cautions for "AIRBAG SYSTEM" in this case. <Ref. to AB-11, CAUTION, General Description.>
- Be careful not to damage the airbag system wiring harness when servicing electrical parts and switches.
- If the steering wheel and steering angle sensor (steering roll connector) are removed, perform "VDC sensor midpoint setting mode" of the VDC. <Ref. to VDC-19, VDC SENSOR MIDPOINT SETTING MODE, ADJUSTMENT, VDC Control Module and Hydraulic Control Unit (VDCCM&H/U).>

C: PREPARATION TOOL

1. SPECIAL TOOL

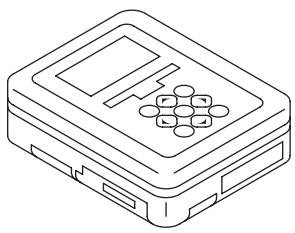
ILLUSTRATION	TOOL NUMBER	DESCRIPTION	REMARKS
 ST1B022XU0	1B022XU0	SUBARU SELECT MONITOR III KIT	Used for setting of each function and troubleshooting for electrical system. NOTE: For detailed operation procedures of SUBARU SELECT MONITOR III KIT, refer to "PC application help for Subaru Select Monitor".

2. GENERAL TOOL

TOOL NAME	REMARKS
Circuit tester	Used for measuring resistance and voltage.
Steering wheel puller	Used for removing the steering wheel.