

16. Hazard Switch

A: REMOVAL

- 1) Disconnect the ground cable from battery.
- 2) On manual A/C models, disconnect the control cables from both sides of the heater and cooling unit assembly.

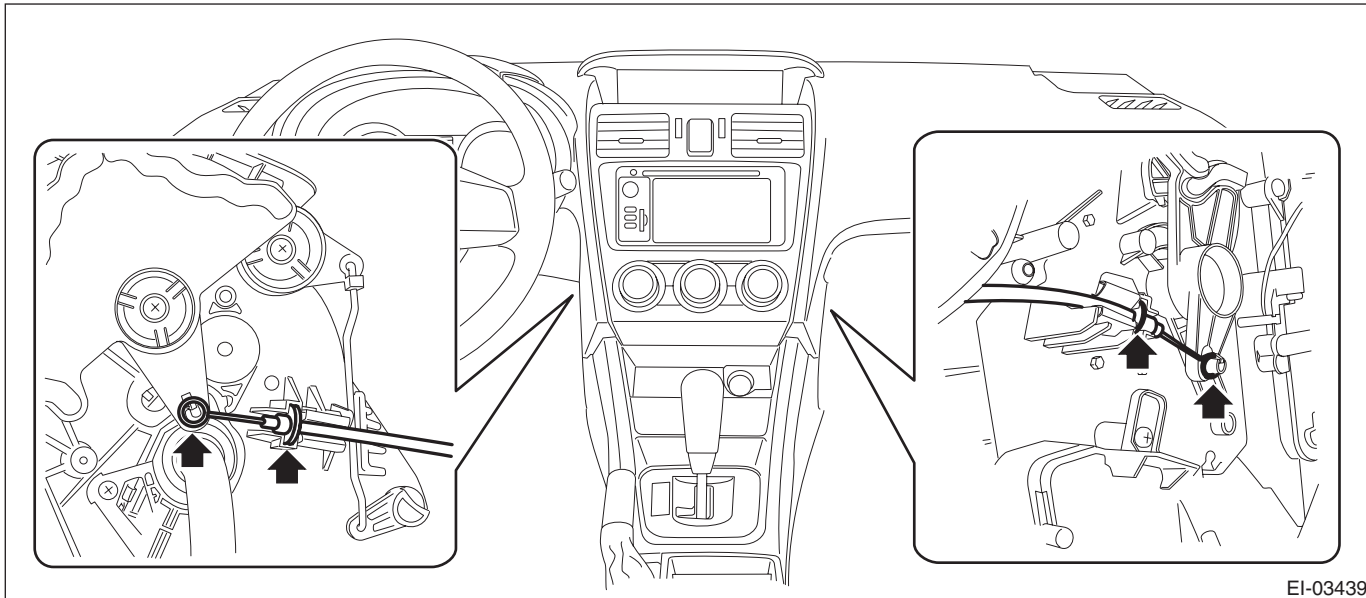

- 3) Remove the panel center assembly.

CAUTION:

Do not put your finger on the fin of the air vent grille. Doing so may damage the fin.

- (1) Insert a plastic remover to the three areas shown by the arrows, and lift up the panel center assembly slightly.
- (2) With the panel center assembly lifted up slightly, release the claw by using a clip remover wrapped with protective tape.
- (3) Release the rest of the claws, and remove the panel center assembly.

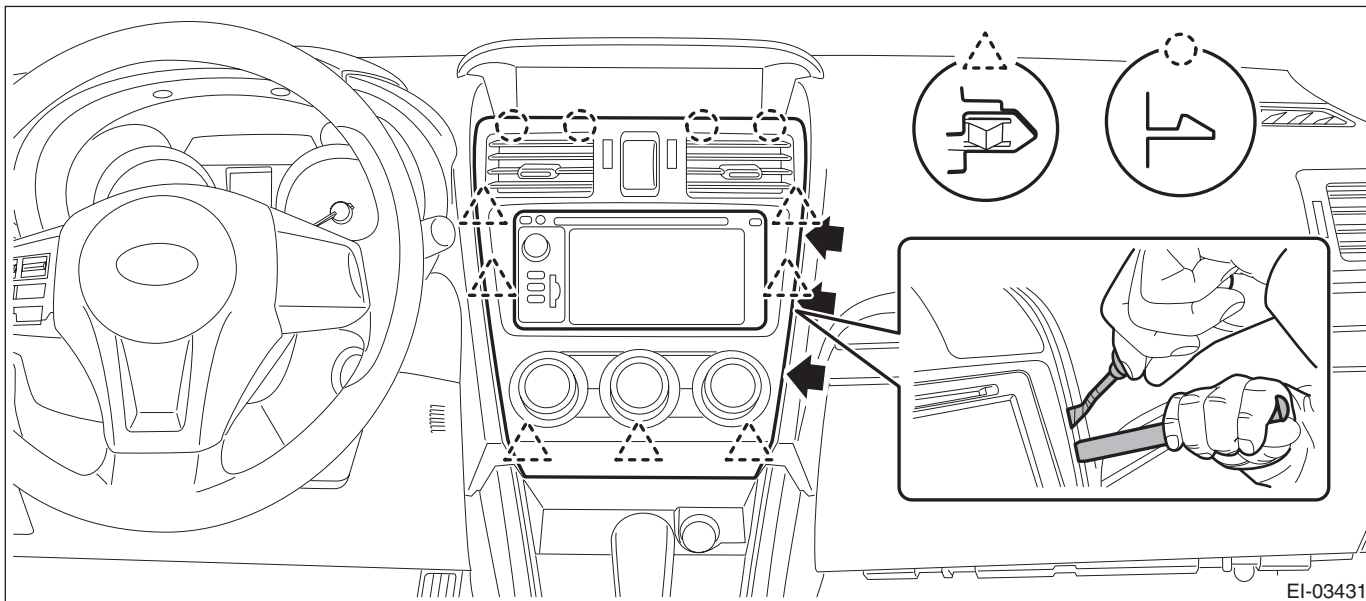

4) Release the claws, and remove the switch - hazard from the panel center assembly.

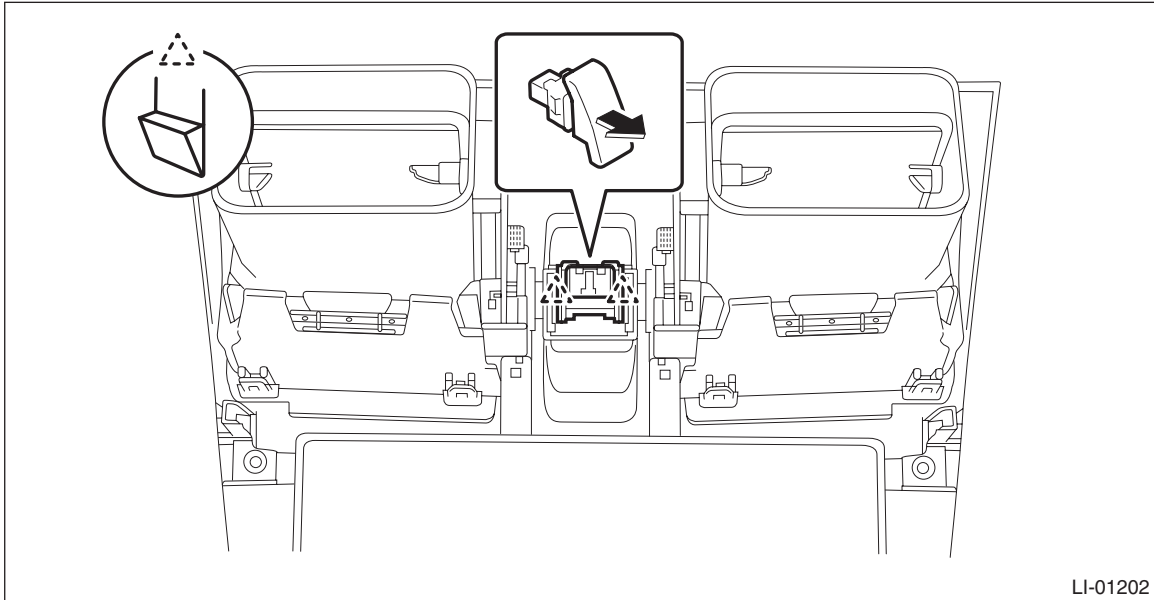

B: INSTALLATION

CAUTION:

After installing the panel center assembly, check that the air vent grille of the panel center assembly is inserted correctly into the air vent duct.

Install each part in the reverse order of removal.

C: INSPECTION

Unit inspection

Preparation tool:

Circuit tester

1) Check the resistance between switch terminals.

Terminal No.	Inspection conditions	Standard	Connection diagram
2 — 3	Switch OFF	1 M Ω or more	
	Switch ON	Less than 1 Ω	

LI-01252

2) Replace the switch - hazard if the inspection result is not within the standard value.