

27.Rear Side Marker Light Bulb

A: REMOVAL

1. 4 DOOR MODEL

It is integrated with the tail light bulb. For details concerning operation procedures, refer to "REMOVAL" of "Tail/Stop Light Bulb". <Ref. to LI-61, REMOVAL, Tail/Stop Light Bulb.>

2. 5 DOOR MODEL/XV MODEL

- 1) Disconnect the ground cable from battery.
- 2) Remove the light assembly - rear combination.

CAUTION:

Be careful not to damage the clips.

- (1) Release the bolts and clips, then pull out the light assembly - rear combination to the vehicle rear.
- (2) Disconnect the connector and remove the light assembly - rear combination.

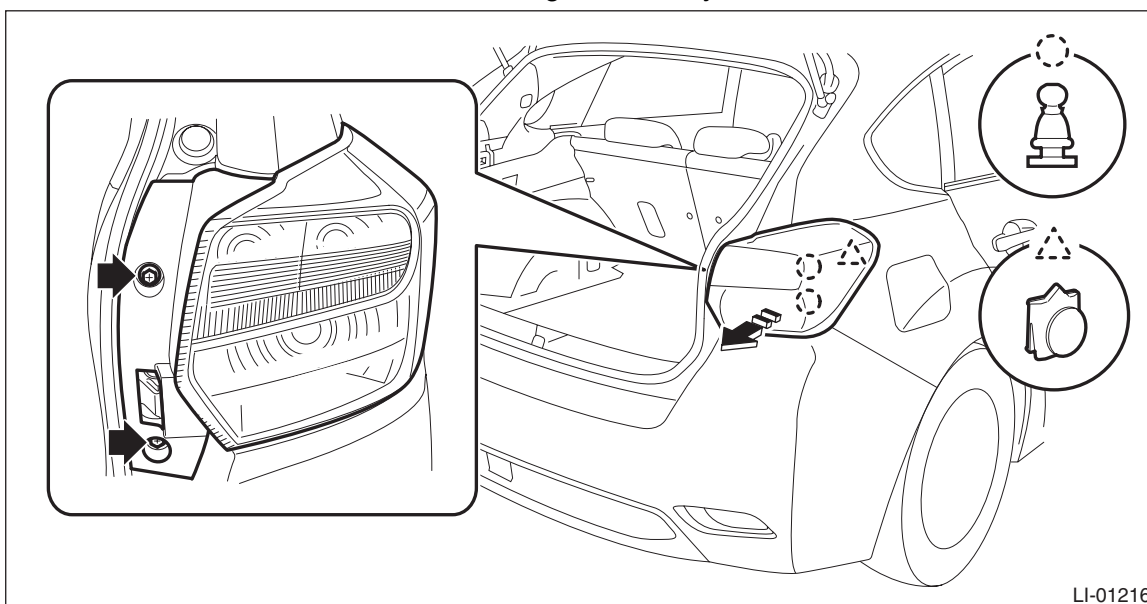

LI-01216

- 3) Remove the bulb socket and rear side marker light bulb.

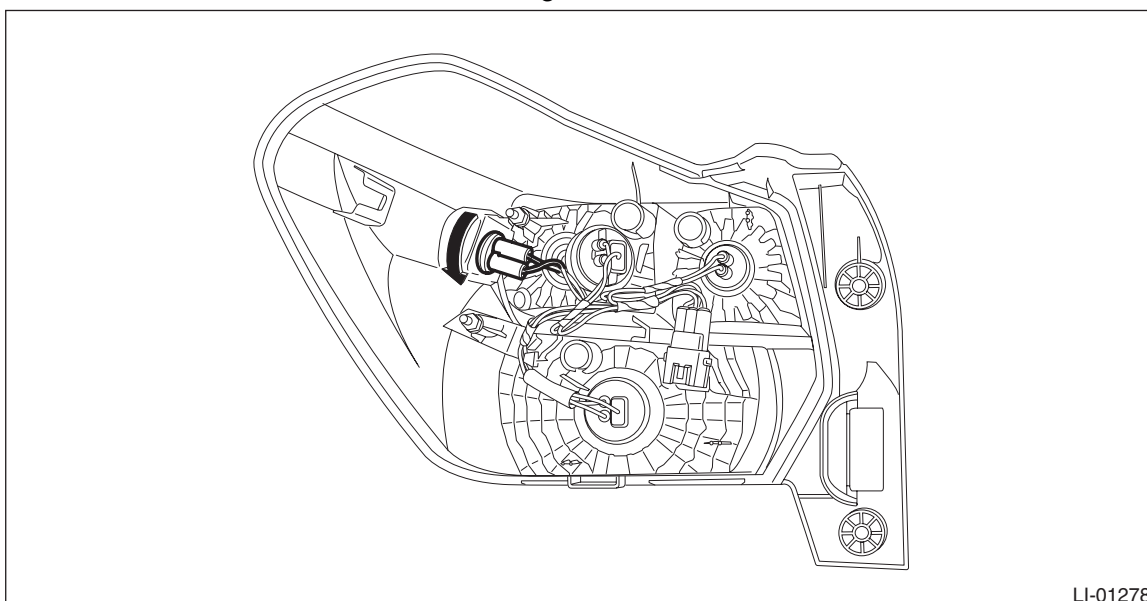

LI-01278

Rear Side Marker Light Bulb

LIGHTING SYSTEM

B: INSTALLATION

Install each part in the reverse order of removal.

Tightening torque:

Light assembly - rear combination (5 door model/XV model): 7.5 N·m (0.76 kgf-m, 5.5 ft-lb)

C: INSPECTION

- 1) Visually check the bulb for blow out.
- 2) Check the bulb specification. <Ref. to LI-2, SPECIFICATION, General Description.>
- 3) Replace the bulb if it is found defective.