

39. Day Time Running Resistor

A: REMOVAL

- 1) Disconnect the ground cable from battery.
- 2) Lift up the vehicle.
- 3) Remove the screw and clips, and turn over the front side of the mud guard - front.

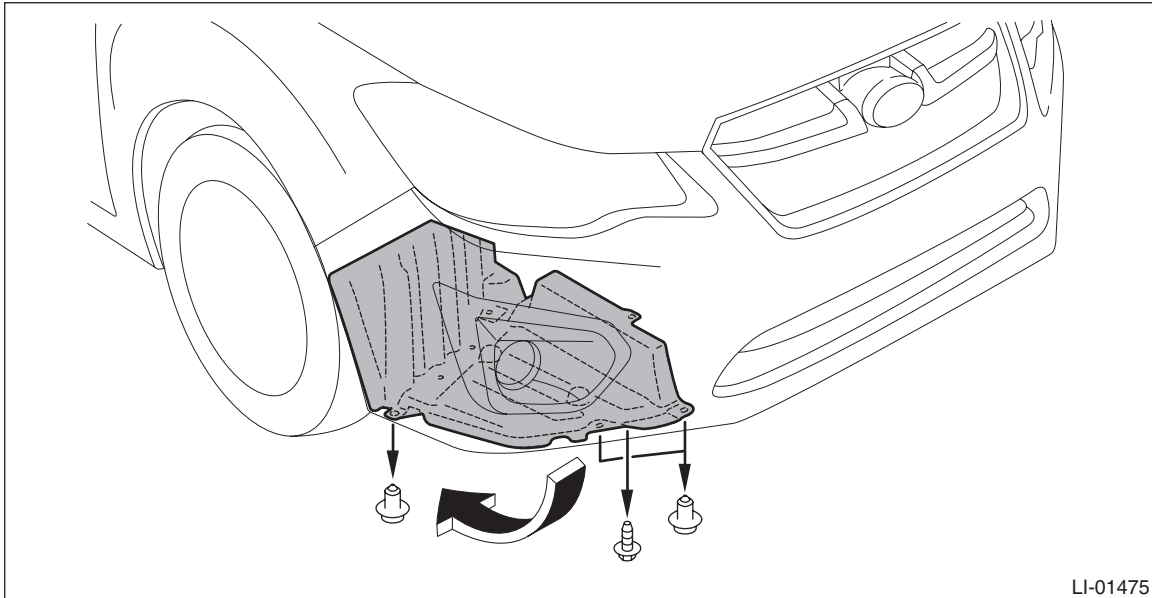

- 4) Remove the resistor assembly - daytime running light.

CAUTION:

The resistor may become hot. Be careful not to burn yourself when removing it.

- (1) Disconnect the connector.
- (2) Remove the bolts, then remove the resistor assembly - daytime running light.

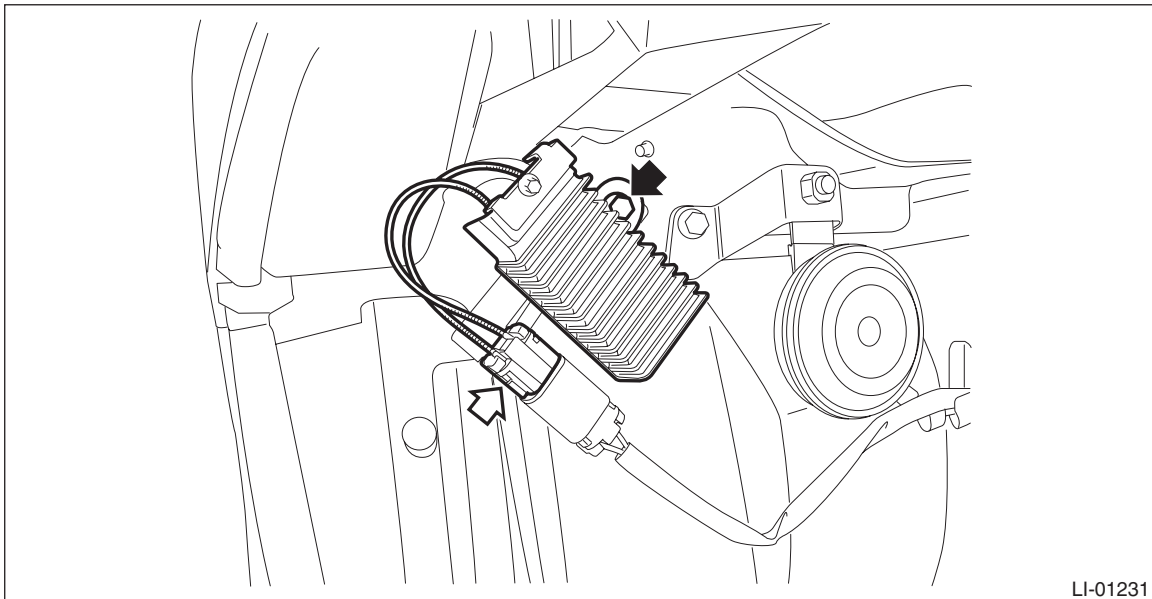

B: INSTALLATION

Install each part in the reverse order of removal.

Tightening torque:

Resistor assembly - daytime running light: 7.5 N·m (0.76 kgf-m, 5.5 ft-lb)