

8. Front Wiper Motor and Link

A: REMOVAL

- 1) Disconnect the ground cable from battery.
- 2) Remove the arm assembly - windshield wiper.
 - (1) Remove the cover - windshield wiper arm.
 - (2) Remove the nuts, and remove the arm assembly - windshield wiper.

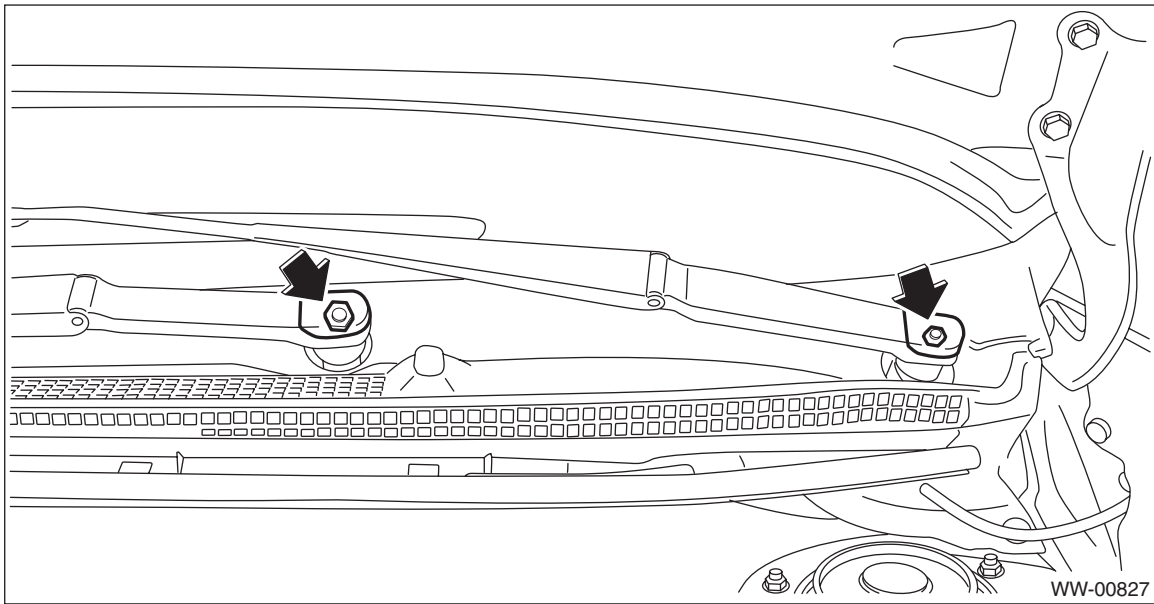

- 3) Remove the cowl panel - side.
 - (1) Remove the clips.
 - (2) Release the claws, and then remove the cowl panel - side.

CAUTION:

Pulling with excessive force may damage the cowl panel - side. If it is difficult to remove, use a plastic remover or equivalent tool.

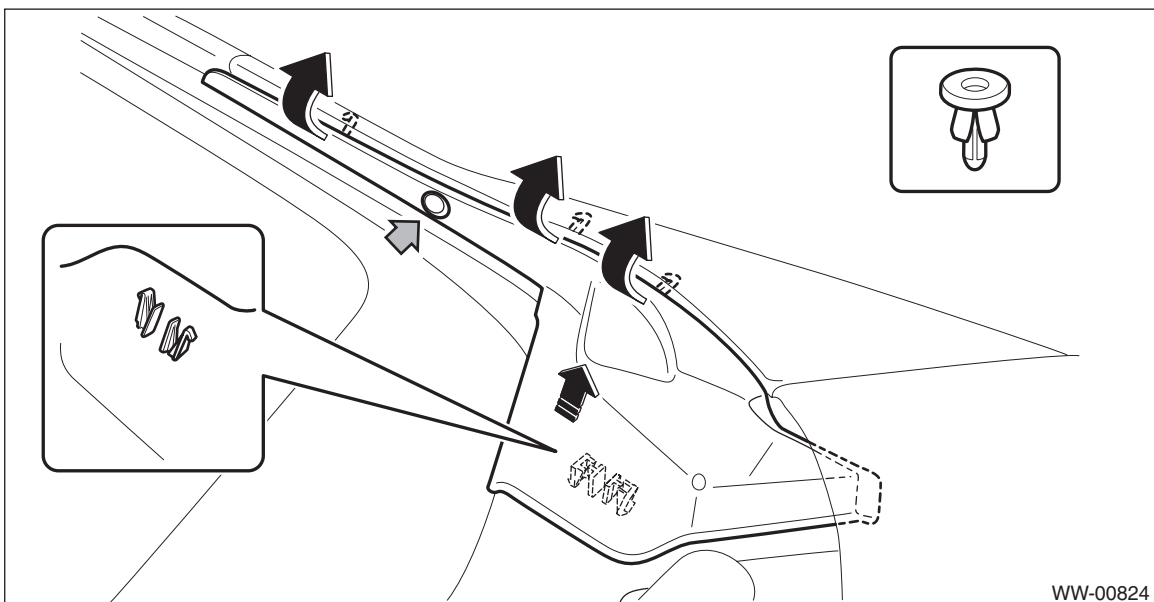

Front Wiper Motor and Link

WIPER AND WASHER SYSTEMS

4) Remove the cowl panel assembly.

CAUTION:

Before removing the cowl panel, use an air blower and nylon brush to sweep gravel from the lower area of the front side of the glass.

- (1) Disconnect the hose - windshield washer.
- (2) Remove clips (A).
- (3) Check the direction of the clip (B), and push the claws from both sides to remove it.

CAUTION:

When removing the clip (B), push the claw of the clip from both sides.

Be careful because the clips (B) can be damaged if you pull unnecessarily hard on them.

- (4) Remove the cowl panel assembly by pulling it out towards the front of the vehicle.

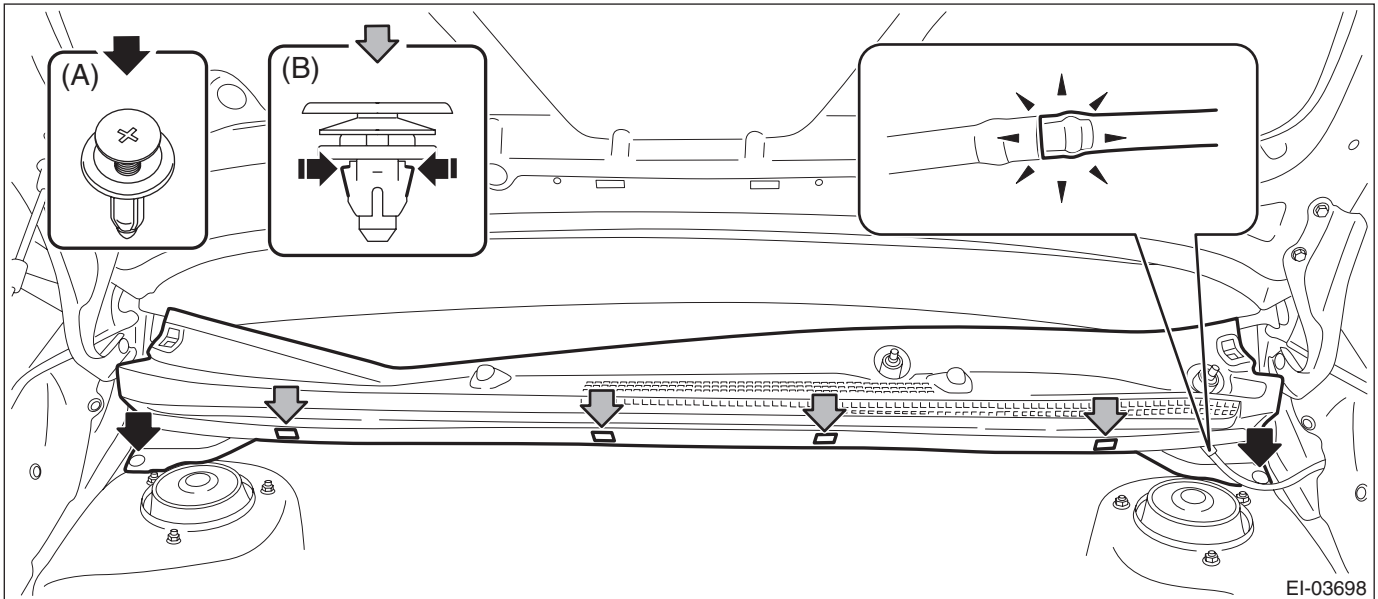

5) Remove the link assembly - windshield wiper.

- (1) Disconnect the connector of the motor assembly - windshield wiper.
- (2) Remove the bolts and harness clips, and remove the link assembly - windshield wiper.

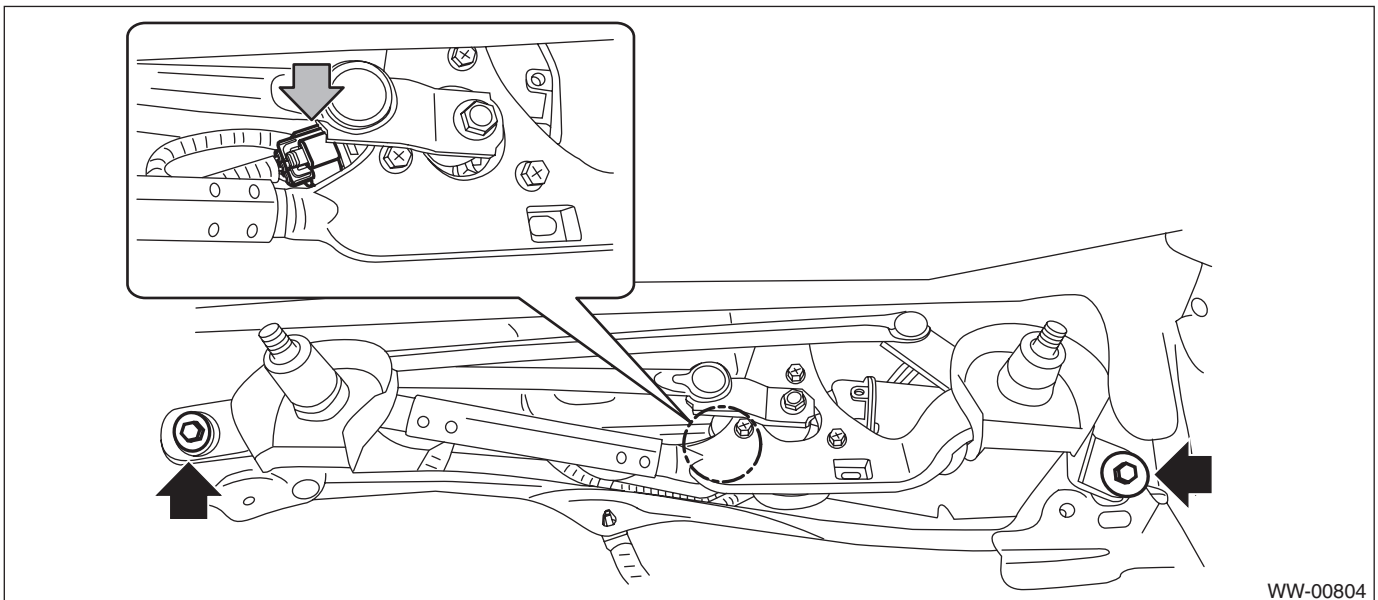

6) Remove the motor assembly - windshield wiper.

(1) Remove the nuts on the link plate and the motor assembly - windshield wiper, and disconnect from the link assembly - windshield wiper.

(2) Remove the bolts, and remove the motor assembly - windshield wiper.

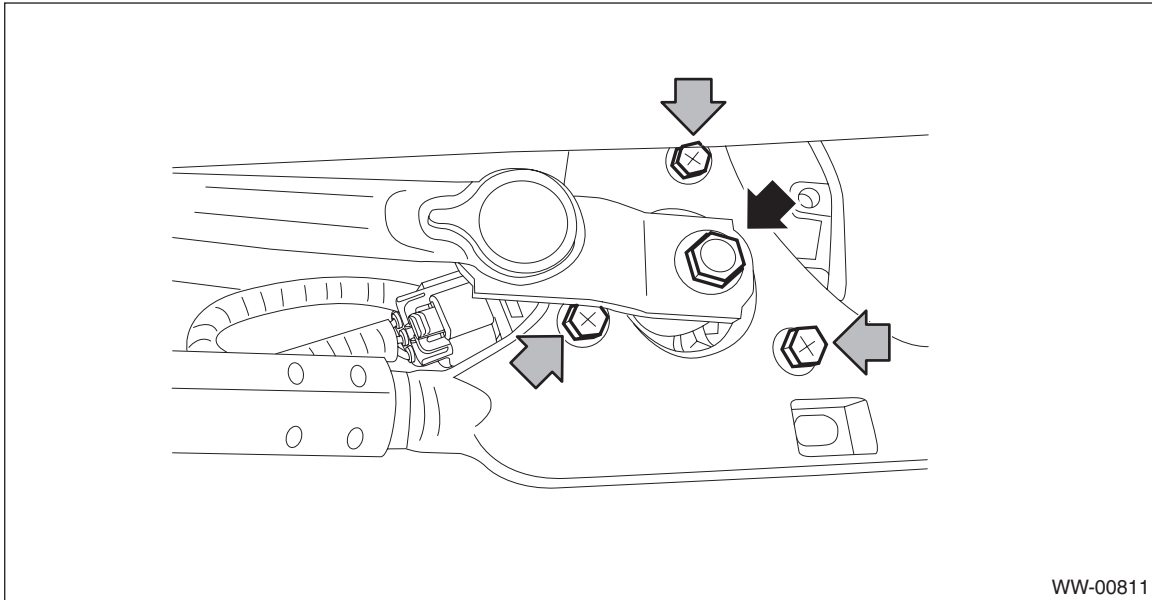

B: INSTALLATION

CAUTION:

Before installing the windshield glass and cowl panel, make sure there are no gravel in the installing area.

1) Connect the battery ground terminal.

2) To confirm that the motor assembly - windshield wiper is at the auto stop position, connect the harness to the motor and turn the wiper switch to ON/OFF once.

CAUTION:

During motor operation, do not touch the movable part.

3) Disconnect the ground cable from battery.

4) Install the motor assembly - windshield wiper.

CAUTION:

Tighten the nut where rod (B) and link plate (A) is aligned in a straight line.

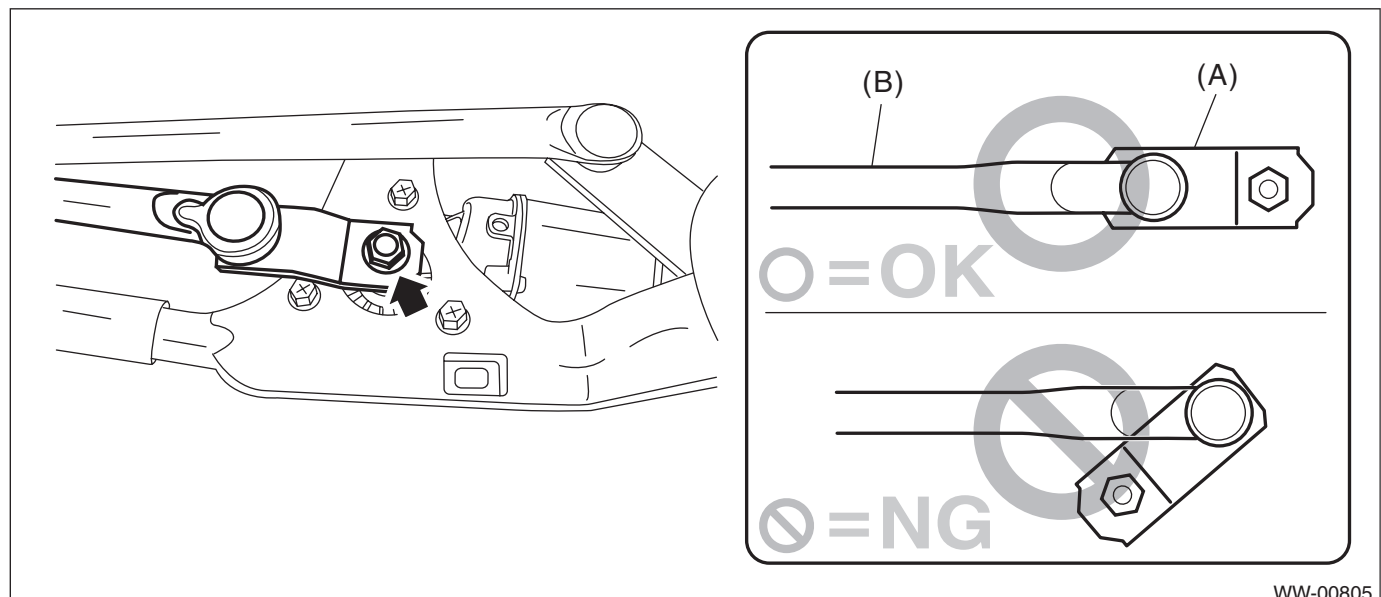

Front Wiper Motor and Link

WIPER AND WASHER SYSTEMS

Tightening torque:

Tighten to 8.5 N·m (0.87 kgf·m, 6.3 ft·lb) by 115°.

5) Install the link assembly - windshield wiper and cowl panel in the reverse order of removal.

Tightening torque:

Refer to "COMPONENT" of "General Description". <Ref. to WW-2, FRONT WIPER, COMPONENT, General Description.>

C: INSPECTION

- 1) When the battery is connected to the terminal of connectors, confirm that the motor operates at low speed.
- 2) When the battery is connected to the terminal of connectors, confirm that the motor operates at high speed.
- 3) Connect the battery to terminals of the connector, and remove the terminal connection with motor rotating at low speed, and stop the motor assembly - windshield wiper in mid-operation.
- 4) Connect the battery and check that the motor stops at the automatic stop position after the motor operates at low speed again.

CAUTION:

Fix the motor to prevent the motor from being shorted by moving during operation.

