

Fuel Filler Pipe

FUEL INJECTION (FUEL SYSTEMS)

26. Fuel Filler Pipe

A: REMOVAL

WARNING:

Place “NO OPEN FLAMES” signs near the working area.

CAUTION:

Be careful not to spill fuel.

- 1) Release the fuel pressure. <Ref. to FU(H4DO)-112, RELEASING OF FUEL PRESSURE, PROCEDURE, Fuel.>
- 2) Drain fuel. <Ref. to FU(H4DO)-113, DRAINING FUEL (WITH SUBARU SELECT MONITOR), PROCEDURE, Fuel.>
- 3) Disconnect the ground cable from battery.

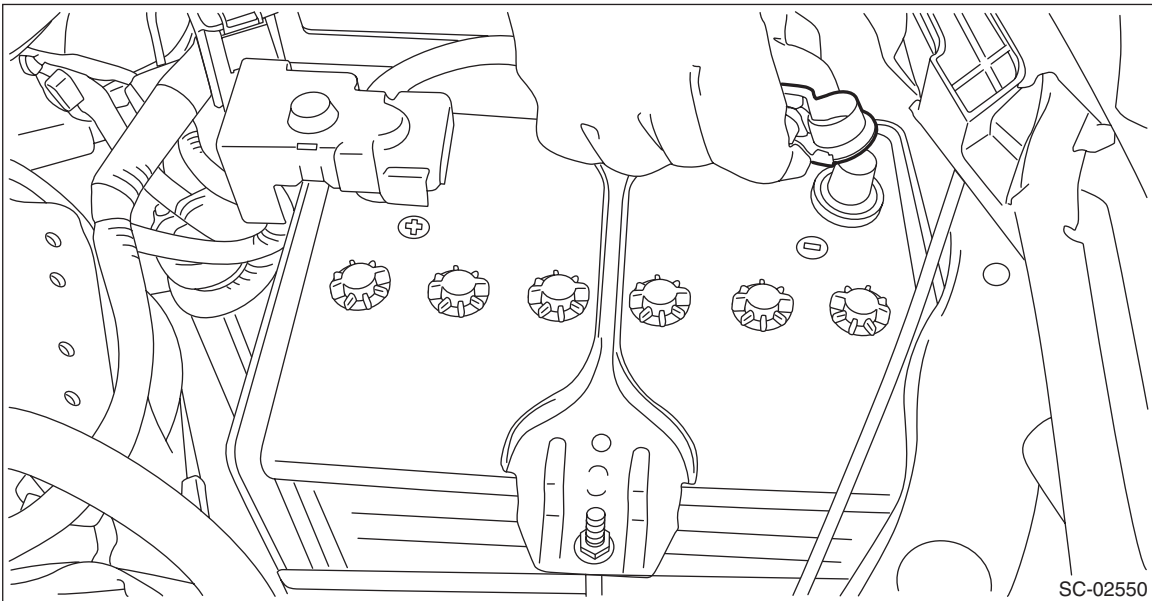

- 4) Open the fuel filler lid and remove the fuel filler cap.
- 5) Turn the fuel filler pipe protector in the direction of the arrow to unlock and remove it.

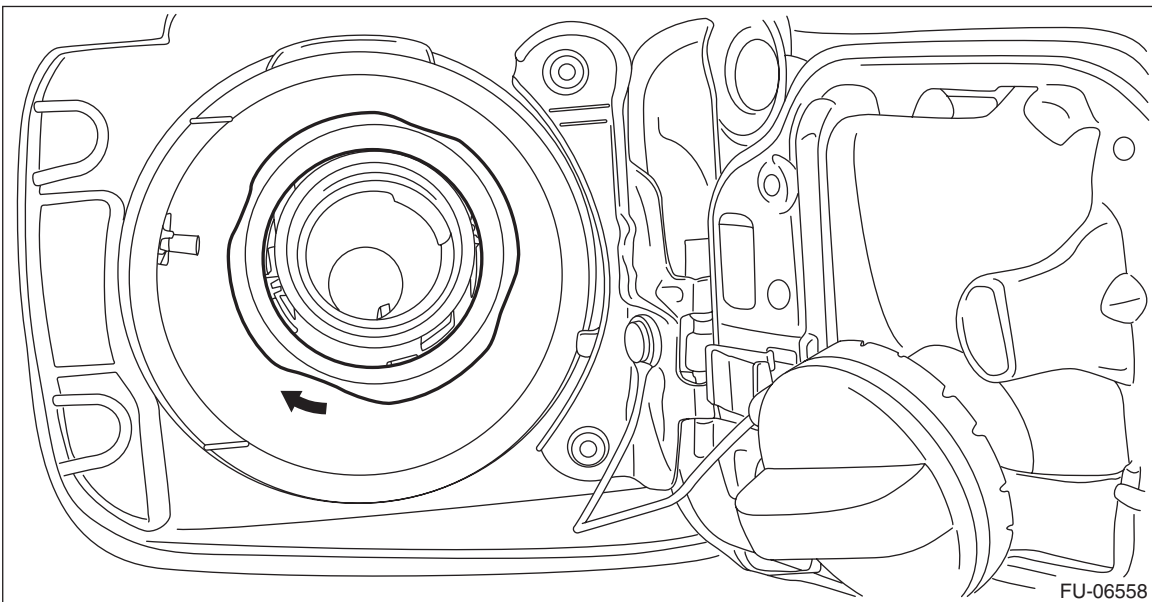

- 6) Remove the rear wheels.
- 7) Lift up the vehicle.

8) Remove the rear ABS wheel speed sensor from the rear housing.

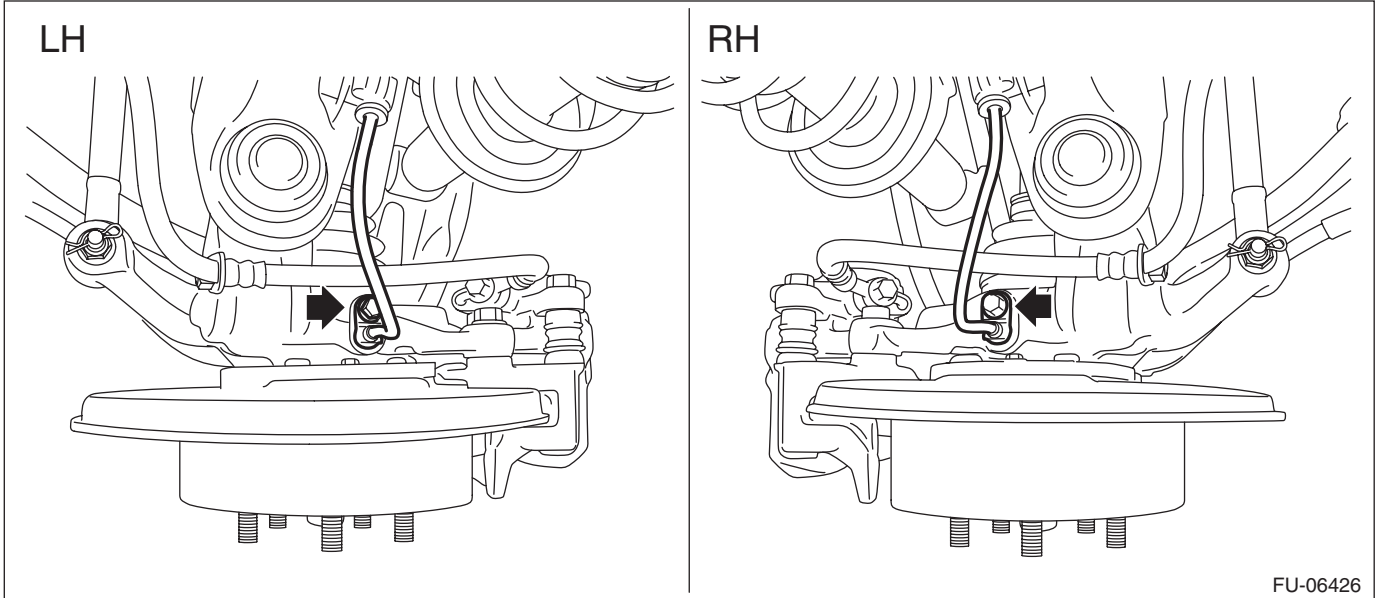

9) Remove the rear ABS wheel speed sensor harness from the upper arm.

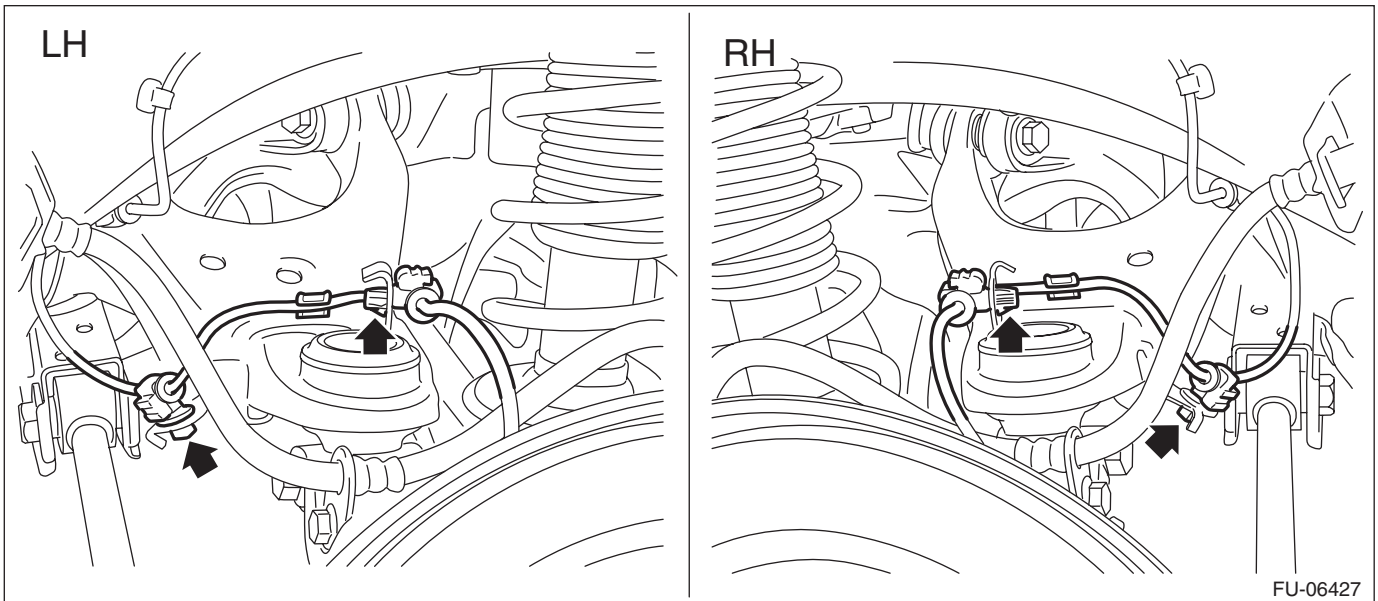

Fuel Filler Pipe

FUEL INJECTION (FUEL SYSTEMS)

10) Remove the rear brake hose bracket from rear housing.

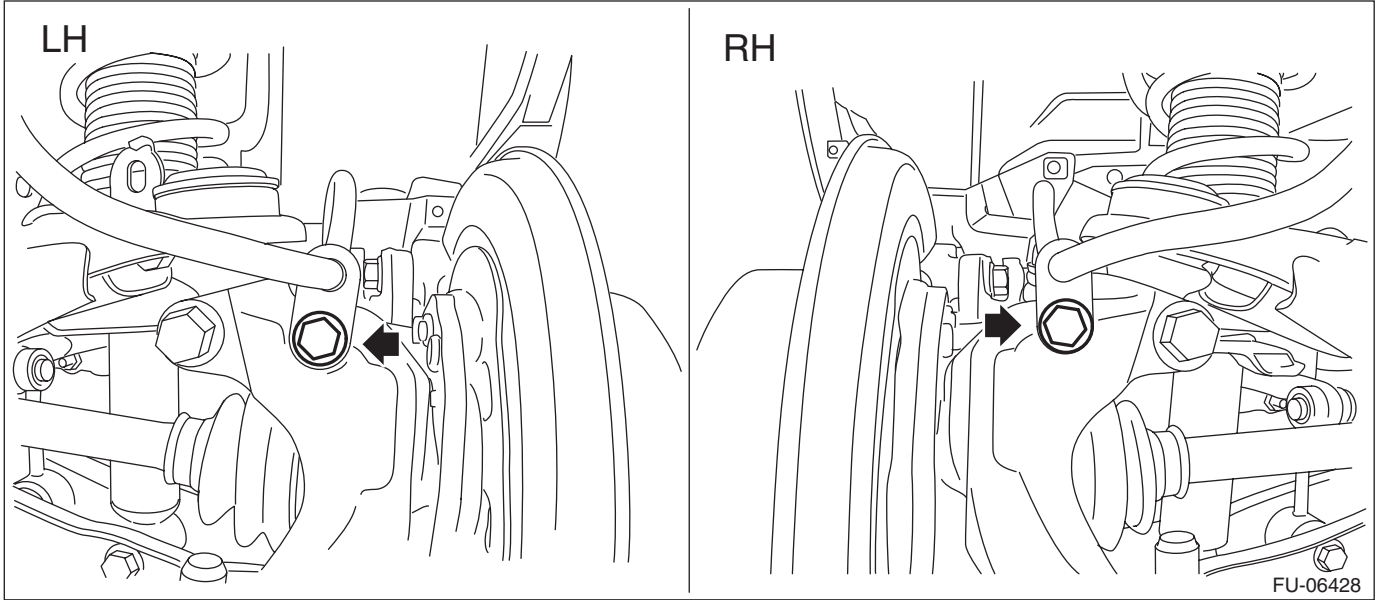

Fuel Filler Pipe

FUEL INJECTION (FUEL SYSTEMS)

11) Remove the rear disc brake assembly and tie it to the body side of the vehicle.

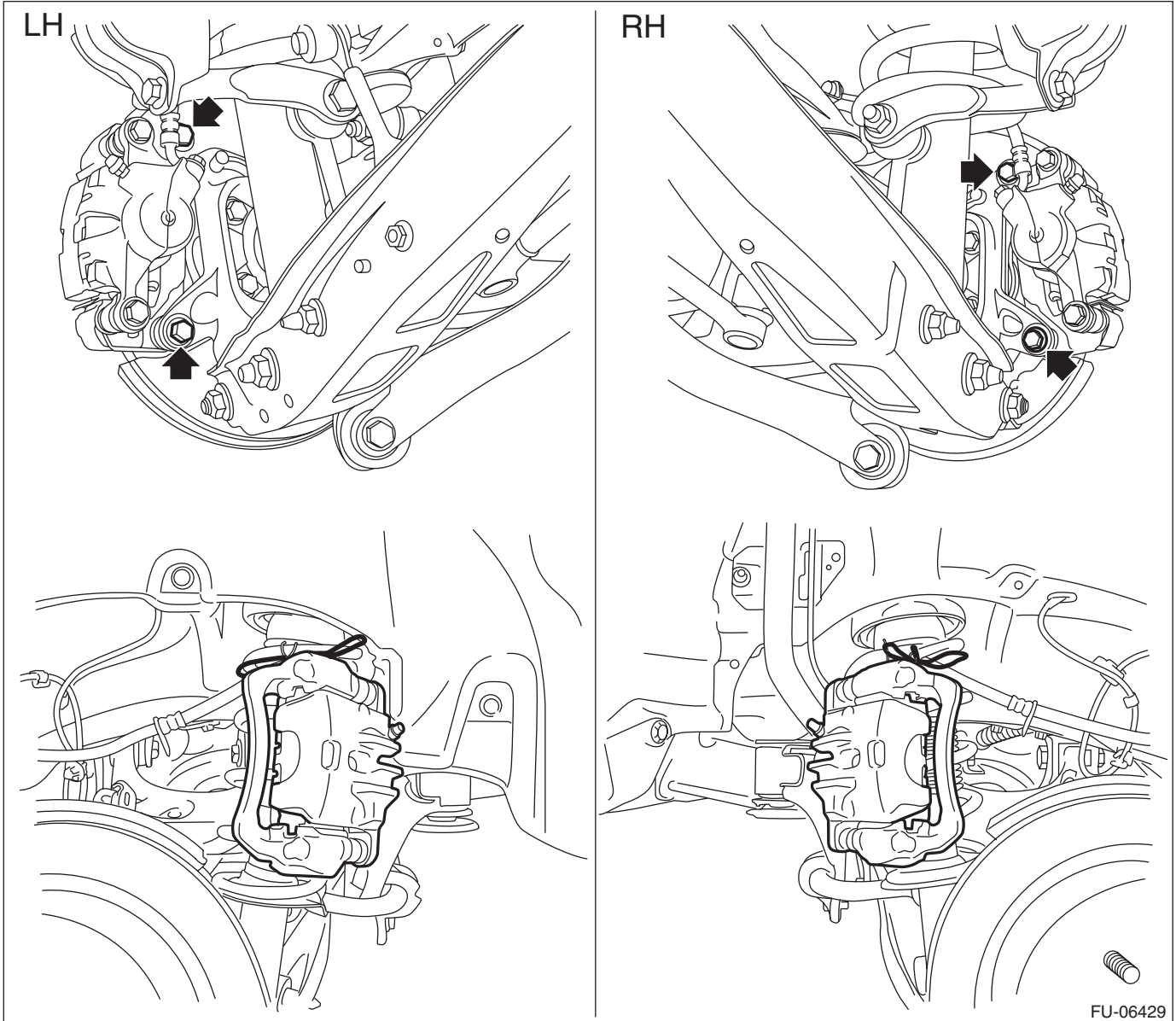

12) Remove the rear exhaust pipe and muffler. <Ref. to EX(H4DO)-15, REMOVAL, Rear Exhaust Pipe.>
<Ref. to EX(H4DO)-19, REMOVAL, Muffler.>

13) Remove the propeller shaft. <Ref. to DS-12, REMOVAL, Propeller Shaft.>

Fuel Filler Pipe

FUEL INJECTION (FUEL SYSTEMS)

14) Remove the fuel tank protector.

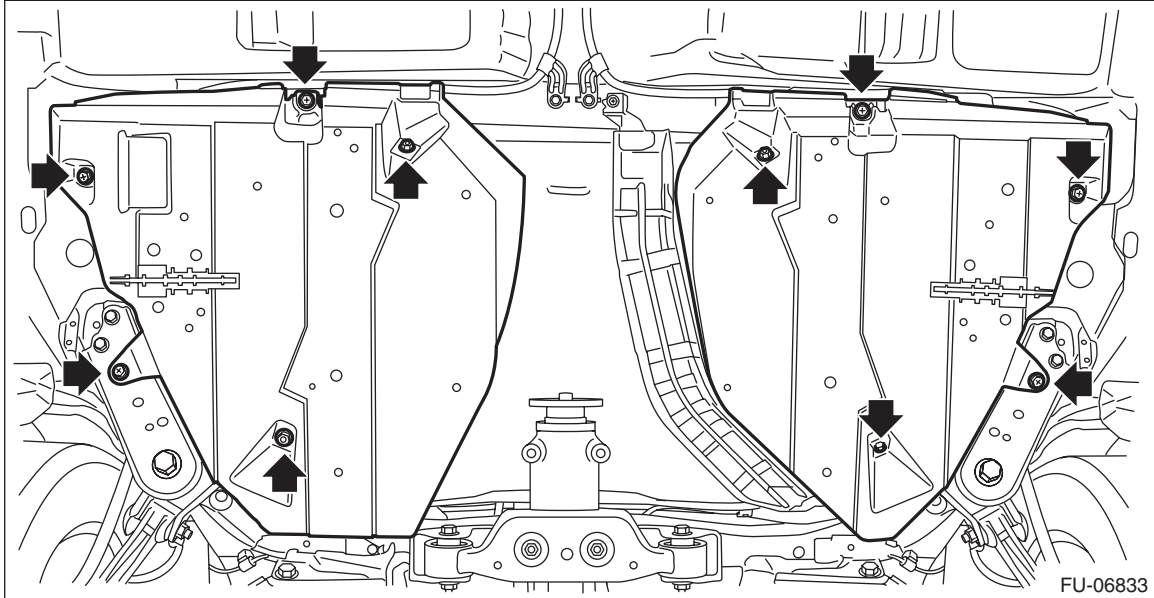

15) Remove the parking brake cable from the parking brake assembly. <Ref. to PB-15, REMOVAL, Parking Brake Assembly (Rear Disc Brake).>

16) Remove the bolts securing the parking brake cable.

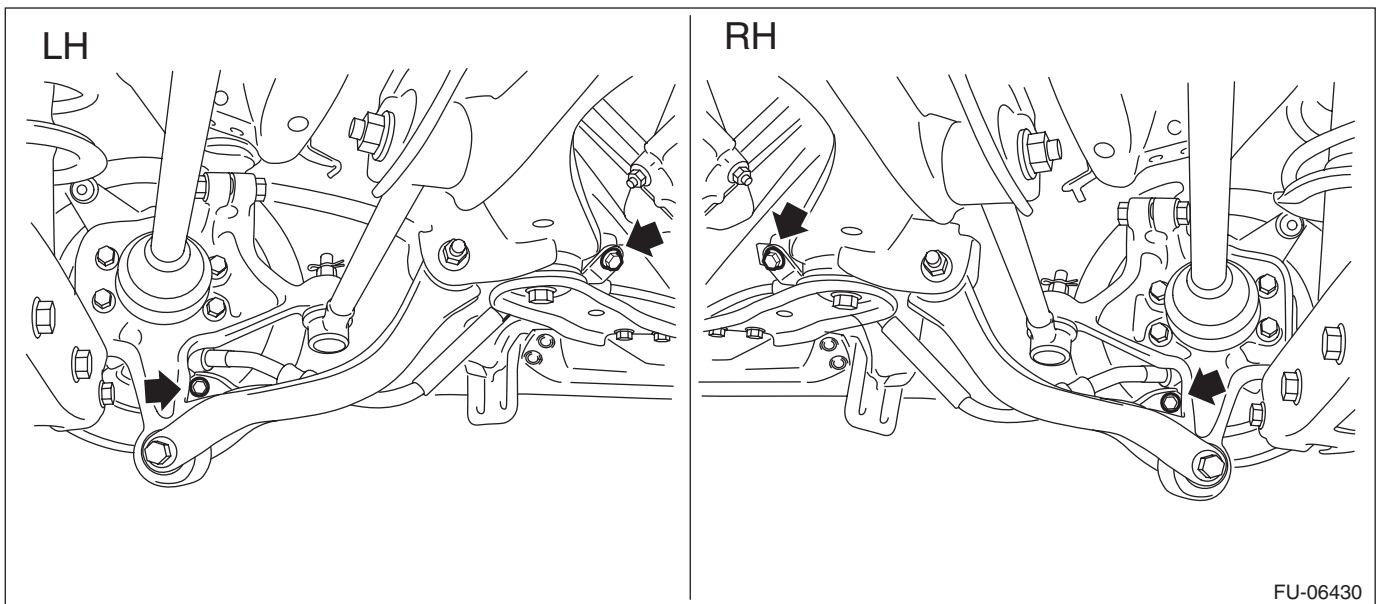

Fuel Filler Pipe

17) Remove the clamp, and pull out the parking brake cable from the back plate.

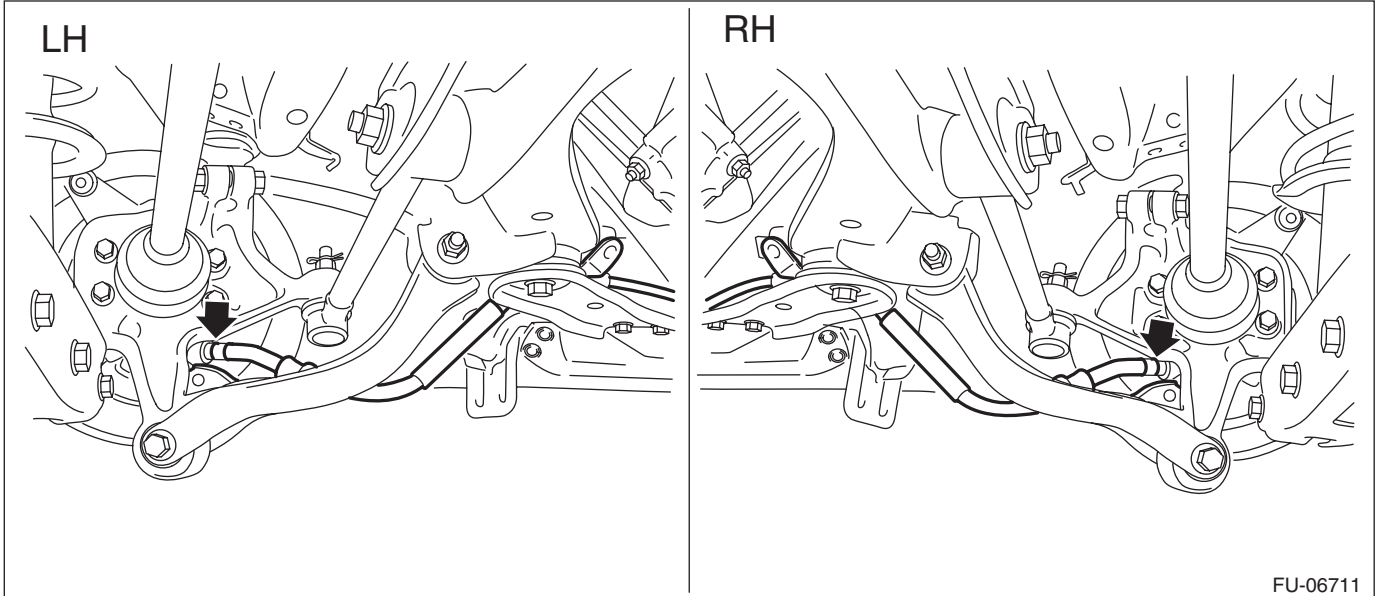

FU-06711

18) Disconnect the connector (A) from the rear vehicle height sensor, and remove the rear vehicle height sensor. (model with auto headlight beam leveler, left side only)

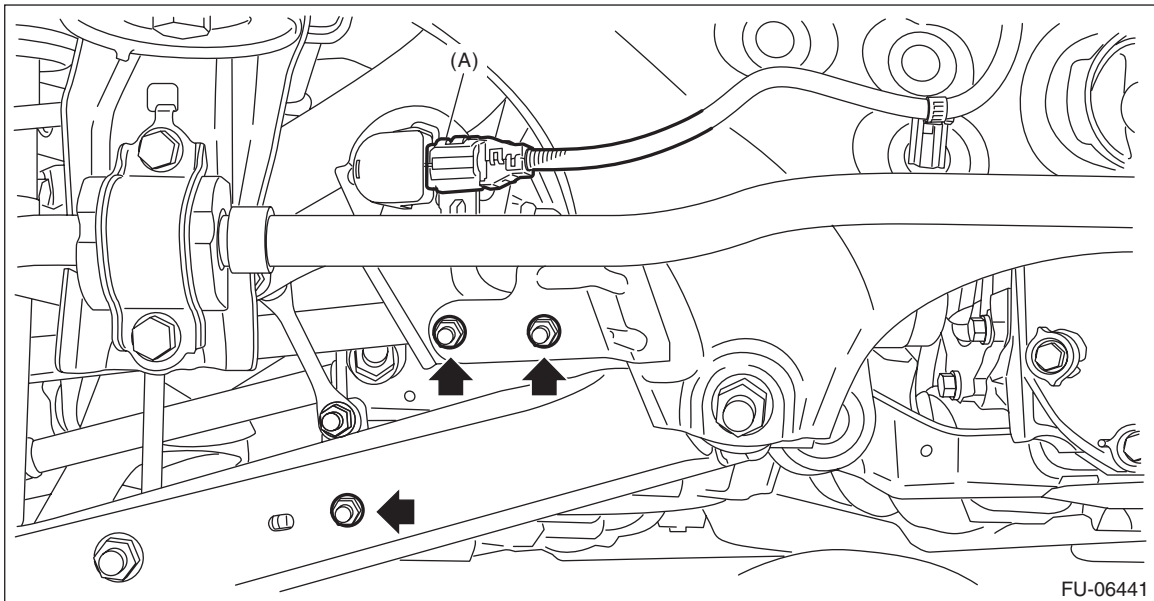

FU-06441

Fuel Filler Pipe

FUEL INJECTION (FUEL SYSTEMS)

19) Remove the rear sub frame assembly.

WARNING:

A helper is required to perform this work.

- (1) Support the rear sub frame assembly with a transmission jack.
- (2) Remove bolts and nuts on the lower side of the rear strut assembly from the rear lateral link.

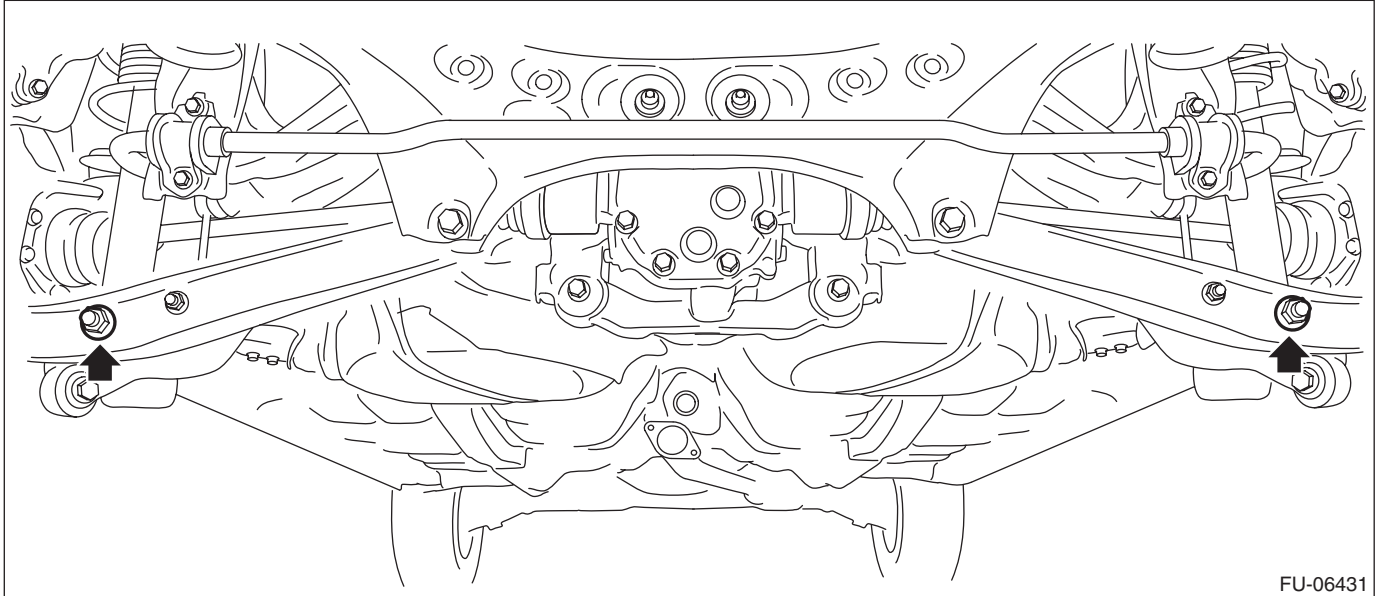

FU-06431

(3) Remove the bolts which secure the rear sub frame assembly to the body.

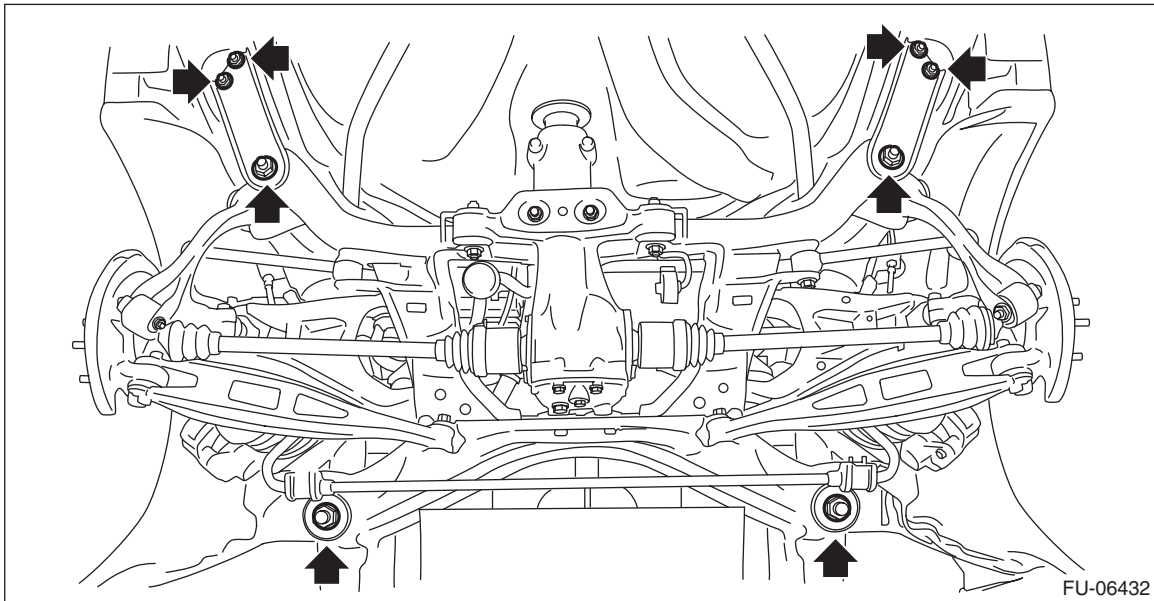

FU-06432

(4) Remove the rear sub frame assembly.

20) Remove the rear mud guard RH. <Ref. to EI-28, REMOVAL, Mud Guard.>

Fuel Filler Pipe

21) Remove the bolts and nuts which secure fuel filler pipe assembly onto the vehicle body.

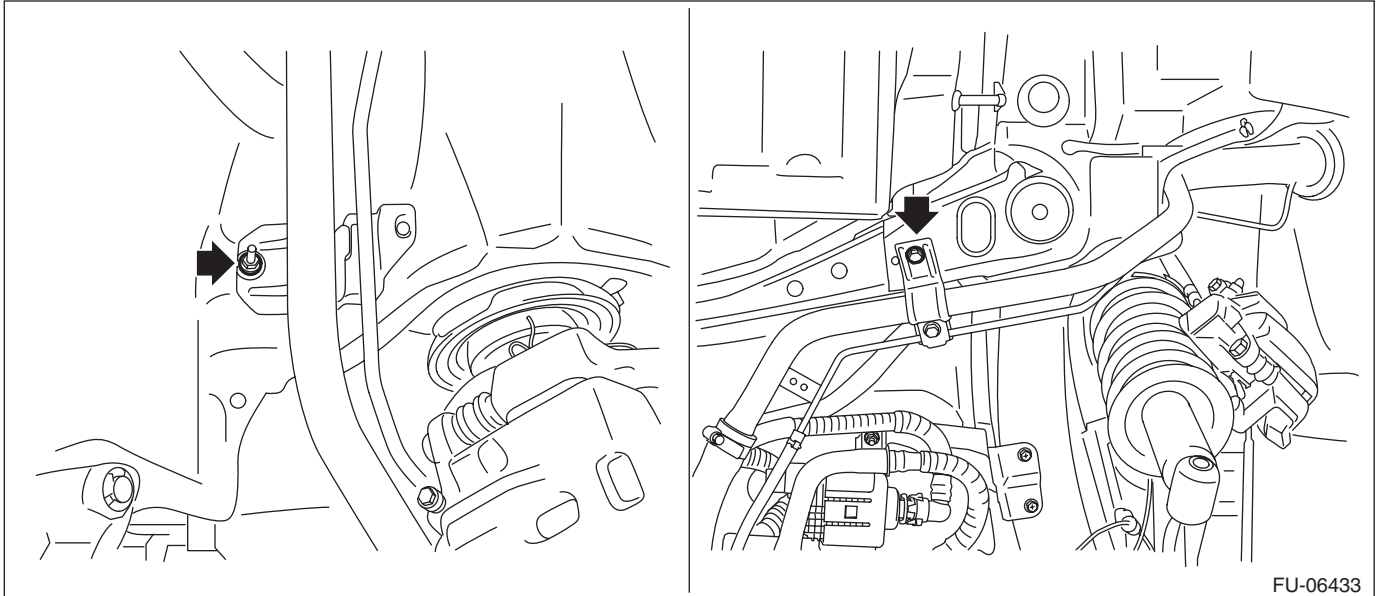

FU-06433

22) Disconnect the fuel filler hose (A) and evaporation hose (B) from the fuel filler pipe assembly.

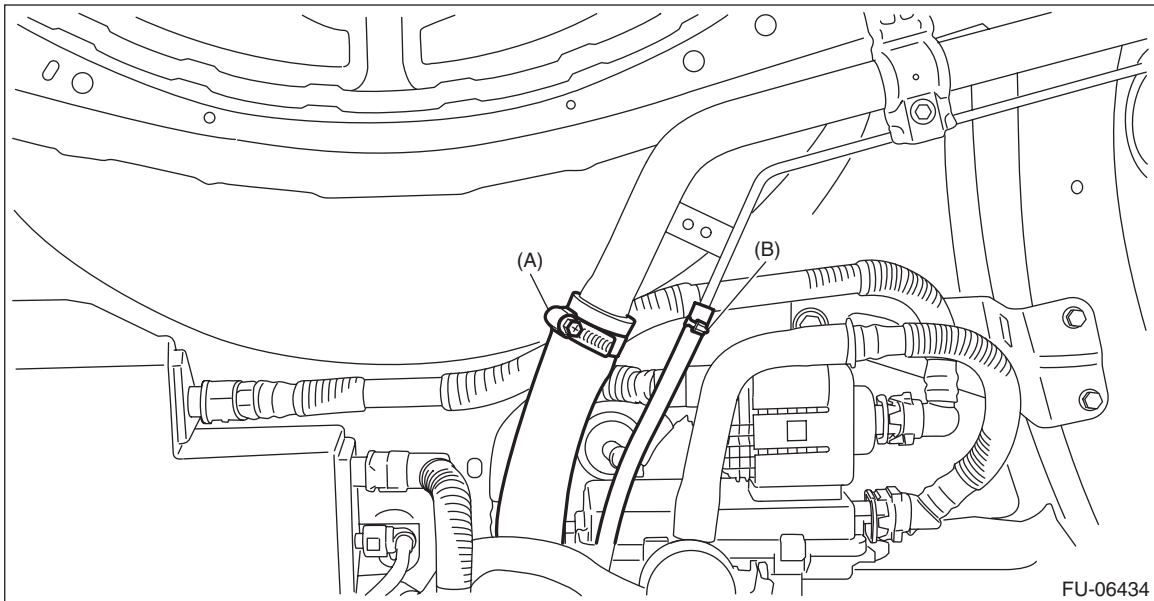

FU-06434

23) Remove the fuel filler pipe assembly from the underside of the vehicle.

Fuel Filler Pipe

FUEL INJECTION (FUEL SYSTEMS)

B: INSTALLATION

- 1) Open the fuel filler lid.
- 2) Insert the fuel filler pipe assembly into the rubber saucer from inside of the rear fender.
- 3) Install the fuel filler pipe assembly to vehicle body.

Tightening torque:

7.5 N·m (0.8 kgf-m, 5.5 ft-lb)

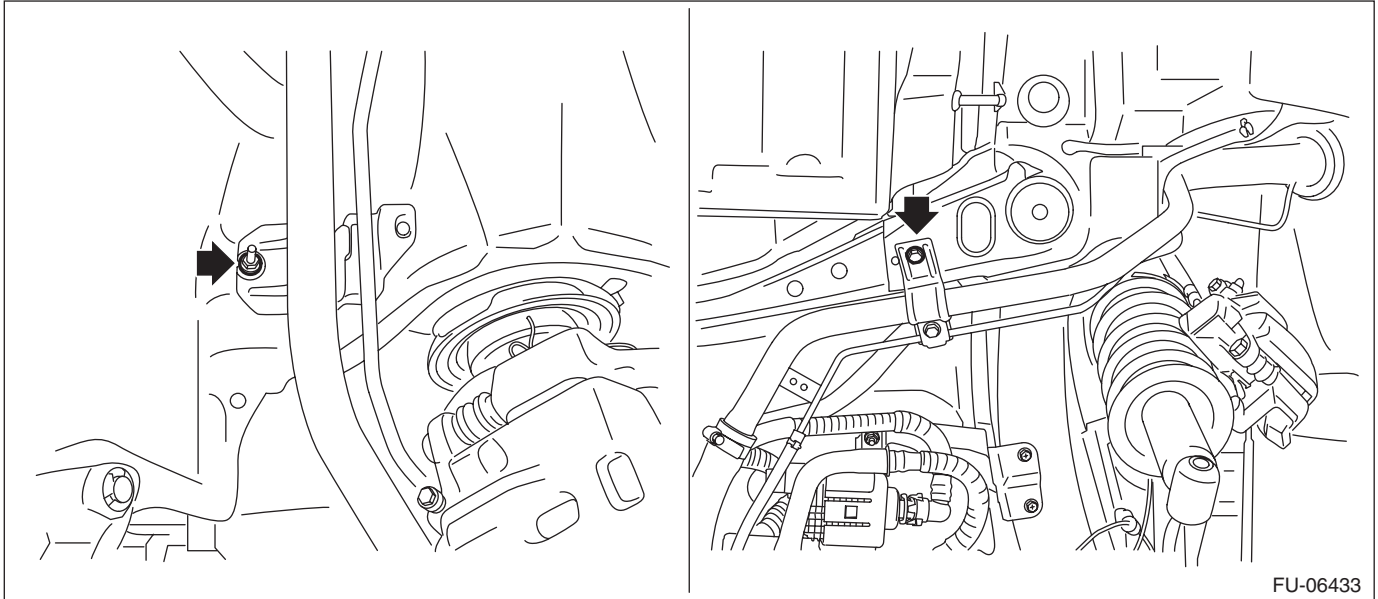

- 4) Install the rear mud guard RH. <Ref. to EI-28, INSTALLATION, Mud Guard.>

Fuel Filler Pipe

5) Securely insert the fuel filler hose (A) and evaporation hose (B) until the hose end contacts the spool, then attach the clamp or clip as shown in the figure.

Tightening torque:

2.5 N·m (0.3 kgf·m, 1.8 ft·lb)

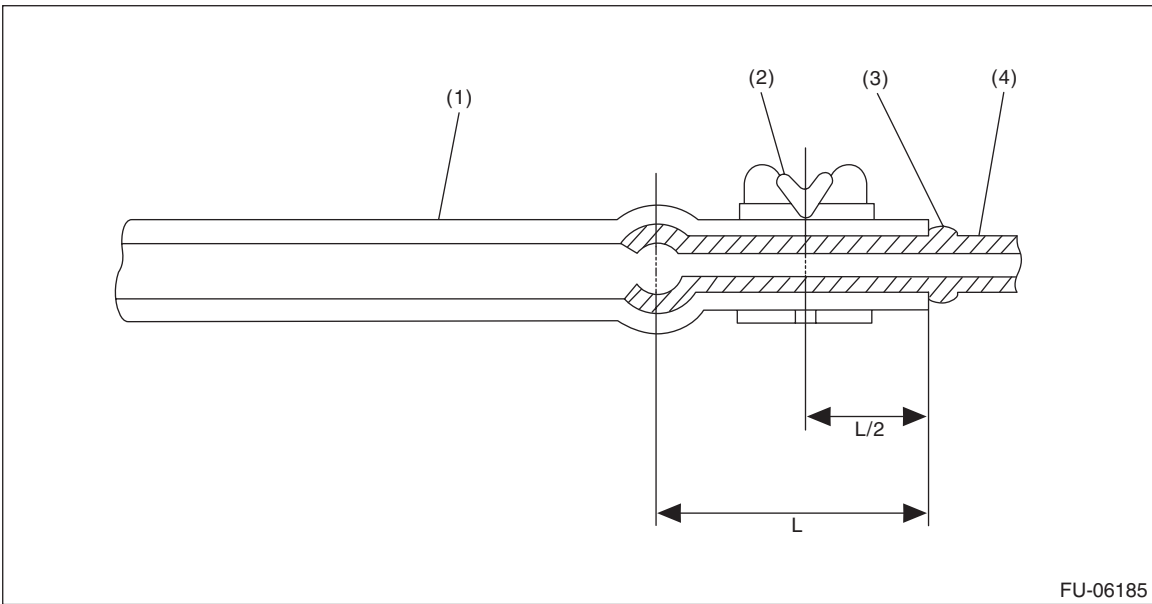
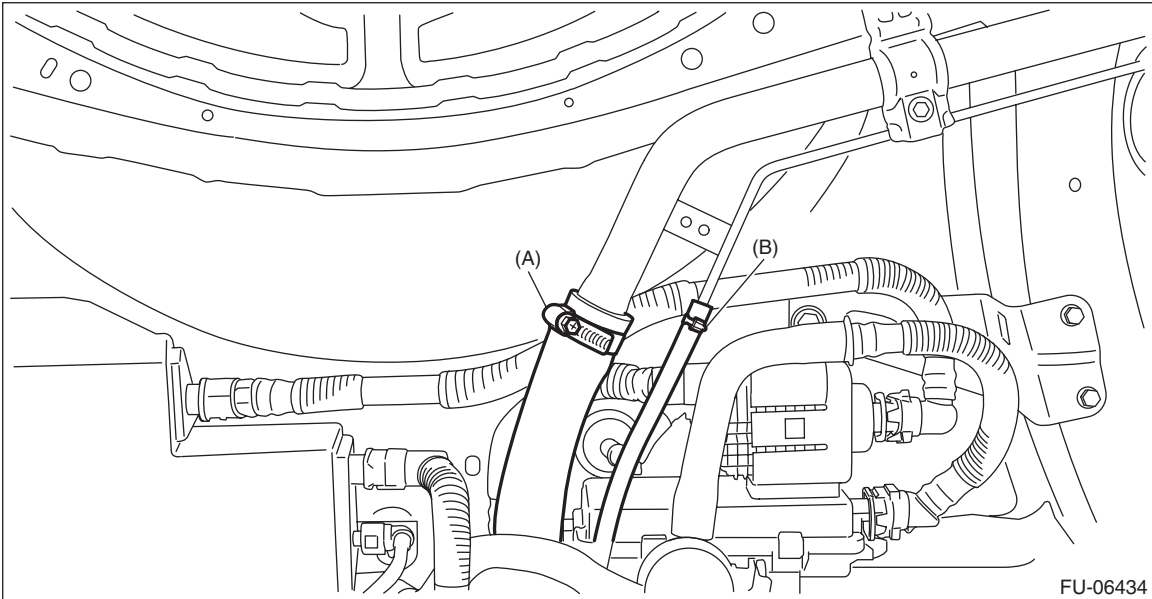

- (1) Hose
- (2) Clamp or clip
- (3) Spool
- (4) Pipe

Fuel Filler Pipe

FUEL INJECTION (FUEL SYSTEMS)

6) Install the rear sub frame assembly.

WARNING:

A helper is required to perform this work.

- (1) Support the rear sub frame assembly with a transmission jack.
- (2) Support the rear sub frame assembly, and install the rear sub frame assembly to the body.

Tightening torque:

T1: 70 N·m (7.1 kgf-m, 51.6 ft-lb)

T2: 145 N·m (14.8 kgf-m, 106.9 ft-lb)

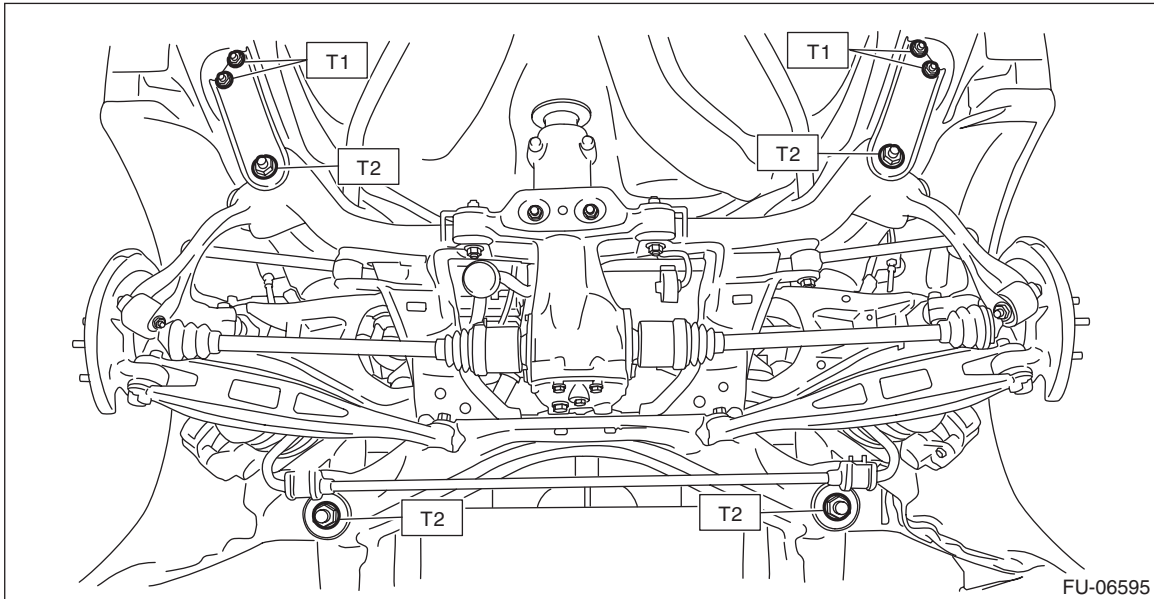

(3) Install the lower side of the rear strut to the rear lateral link.

NOTE:

Use a new self-locking nut.

Tightening torque:

120 N·m (12.2 kgf-m, 88.5 ft-lb)

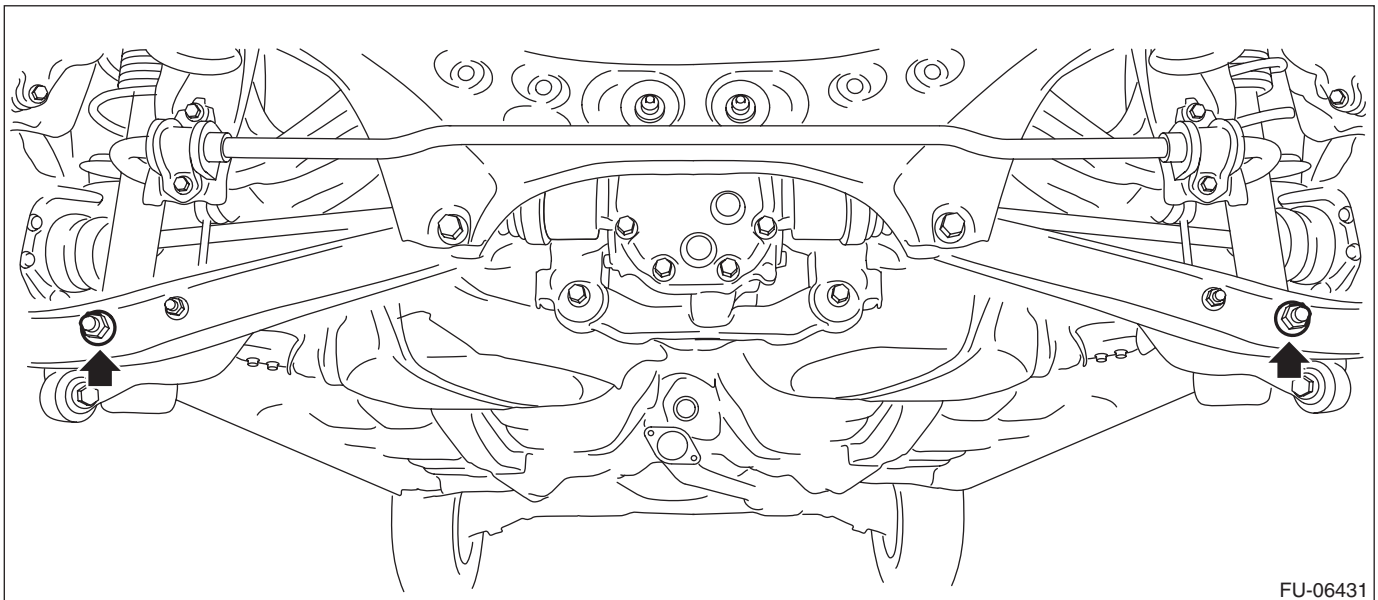

Fuel Filler Pipe

FUEL INJECTION (FUEL SYSTEMS)

7) Install the rear vehicle height sensor and connect the connector (A) to the rear vehicle height sensor. (Model with auto headlight beam leveler, left side only)

Tightening torque:

7.5 N·m (0.8 kgf-m, 5.5 ft-lb)

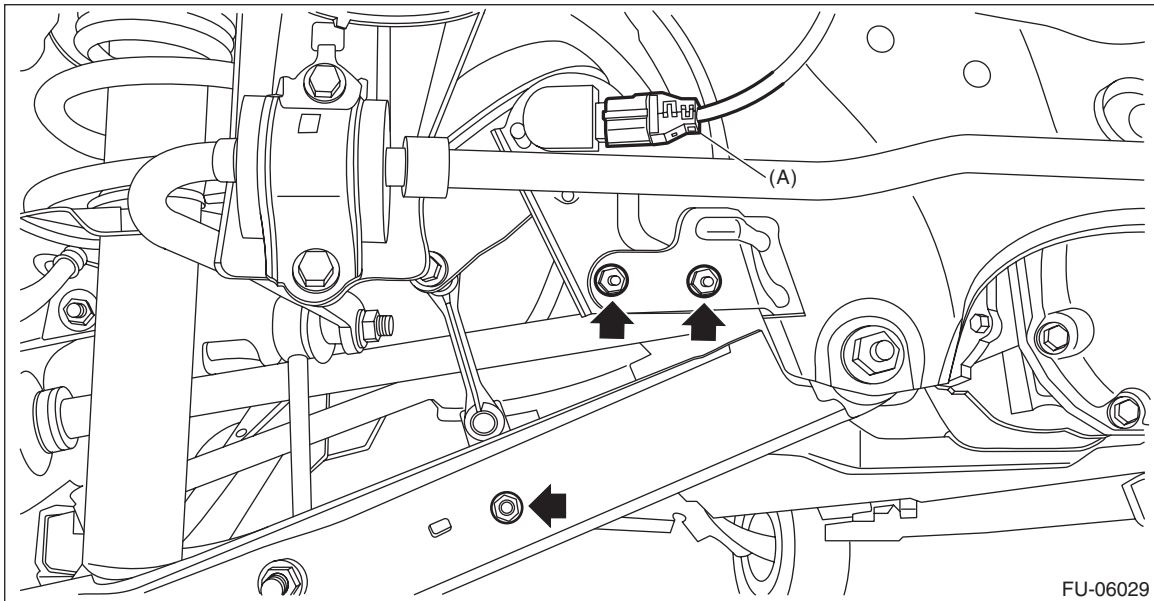

8) Insert the parking brake cable into the back plate, and install it with the clamp.

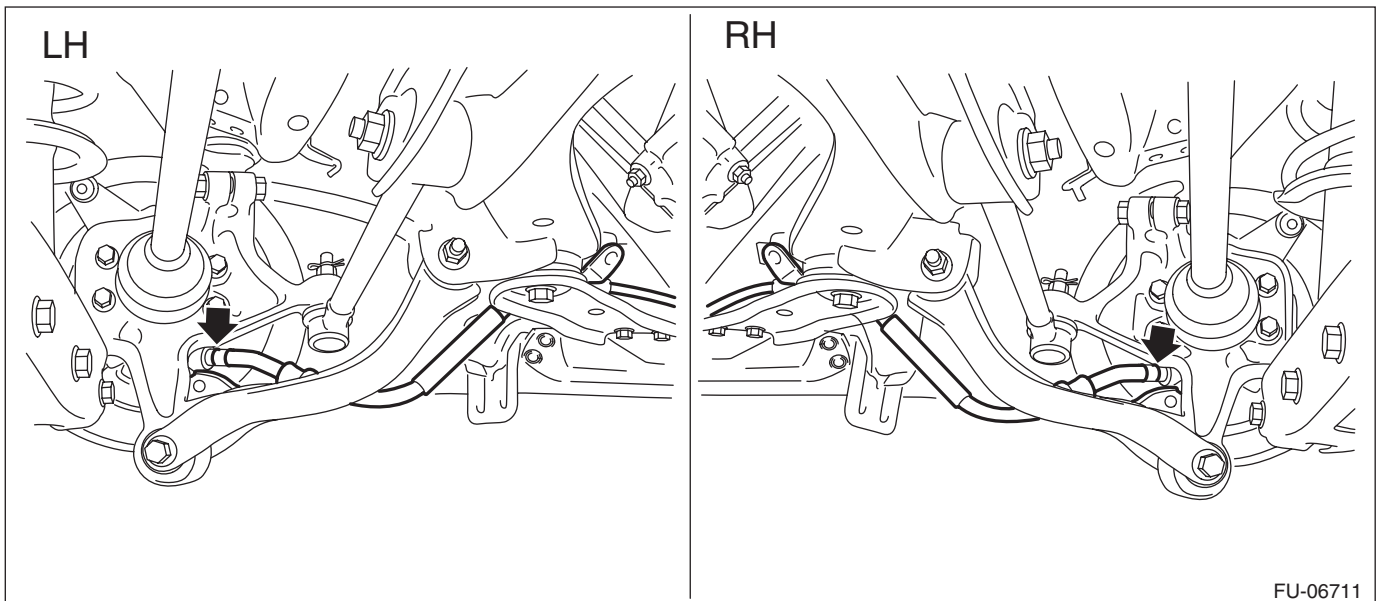

Fuel Filler Pipe

FUEL INJECTION (FUEL SYSTEMS)

9) Secure the parking brake cable with bolts.

Tightening torque:

18 N·m (1.8 kgf-m, 13.3 ft-lb)

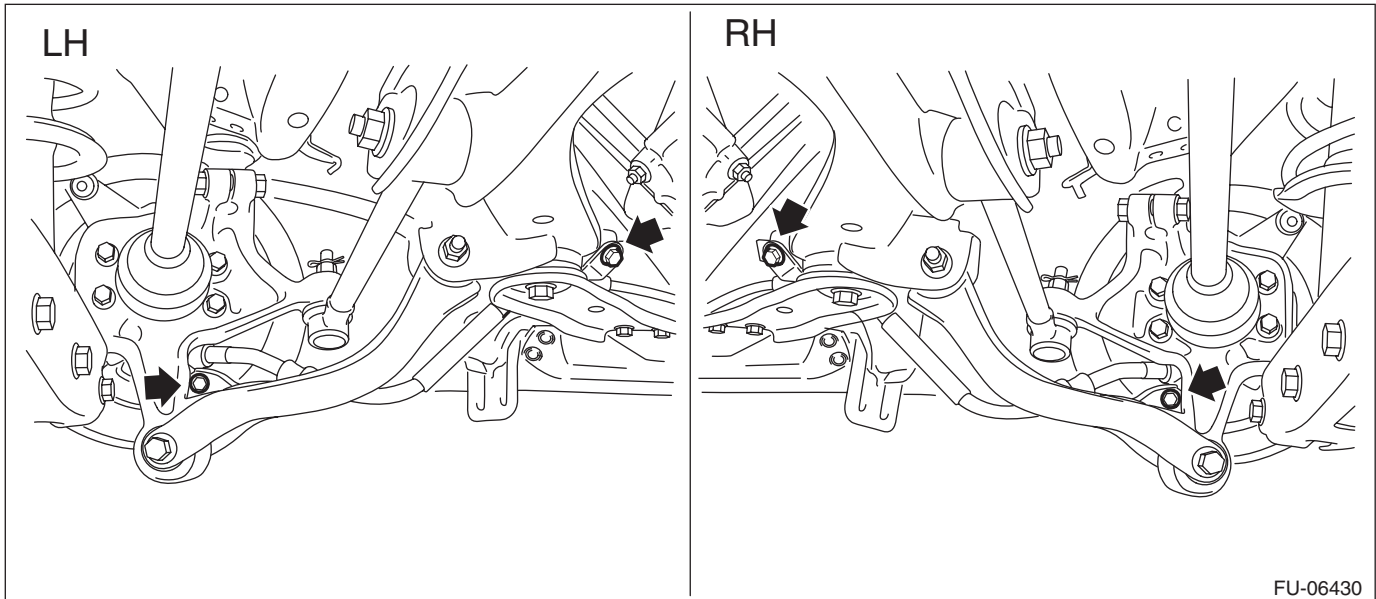

10) Connect the parking brake cable to the parking brake assembly. <Ref. to PB-19, INSTALLATION, Parking Brake Assembly (Rear Disc Brake).>

11) Install the fuel tank protector.

NOTE:

Use a new self-locking nut.

Tightening torque:

T1: 9 N·m (0.9 kgf-m, 6.6 ft-lb)

T2: 18 N·m (1.8 kgf-m, 13.3 ft-lb)

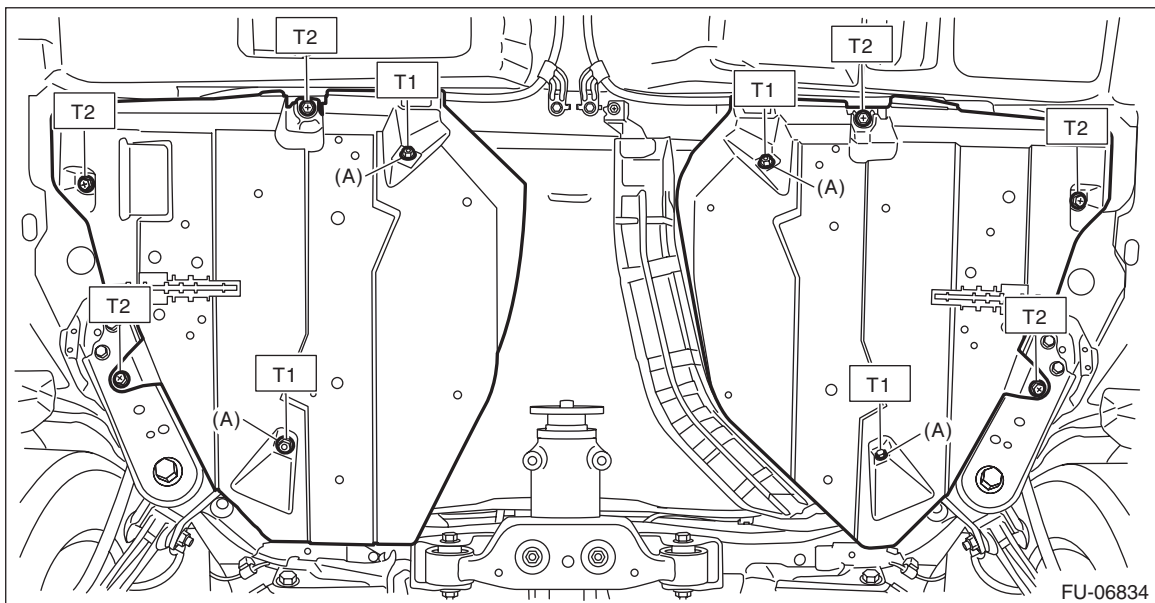

(A) Self-locking nut

12) Install the propeller shaft. <Ref. to DS-13, INSTALLATION, Propeller Shaft.>

13) Install the rear exhaust pipe and muffler. <Ref. to EX(H4DO)-17, INSTALLATION, Rear Exhaust Pipe.>
<Ref. to EX(H4DO)-22, INSTALLATION, Muffler.>

Fuel Filler Pipe

14) Install the rear disc brake assembly.

Tightening torque:

66 N·m (6.7 kgf·m, 48.7 ft·lb)

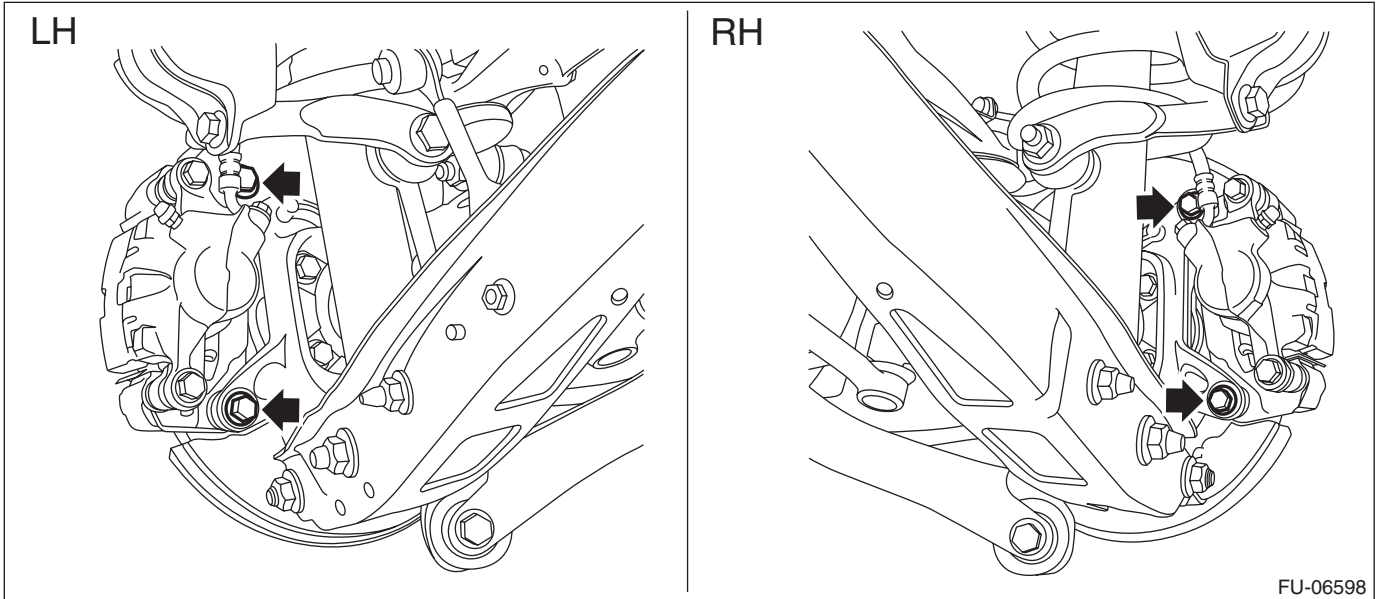

FU-06598

15) Install the rear brake hose bracket to the rear housing.

Tightening torque:

33 N·m (3.4 kgf·m, 24.3 ft·lb)

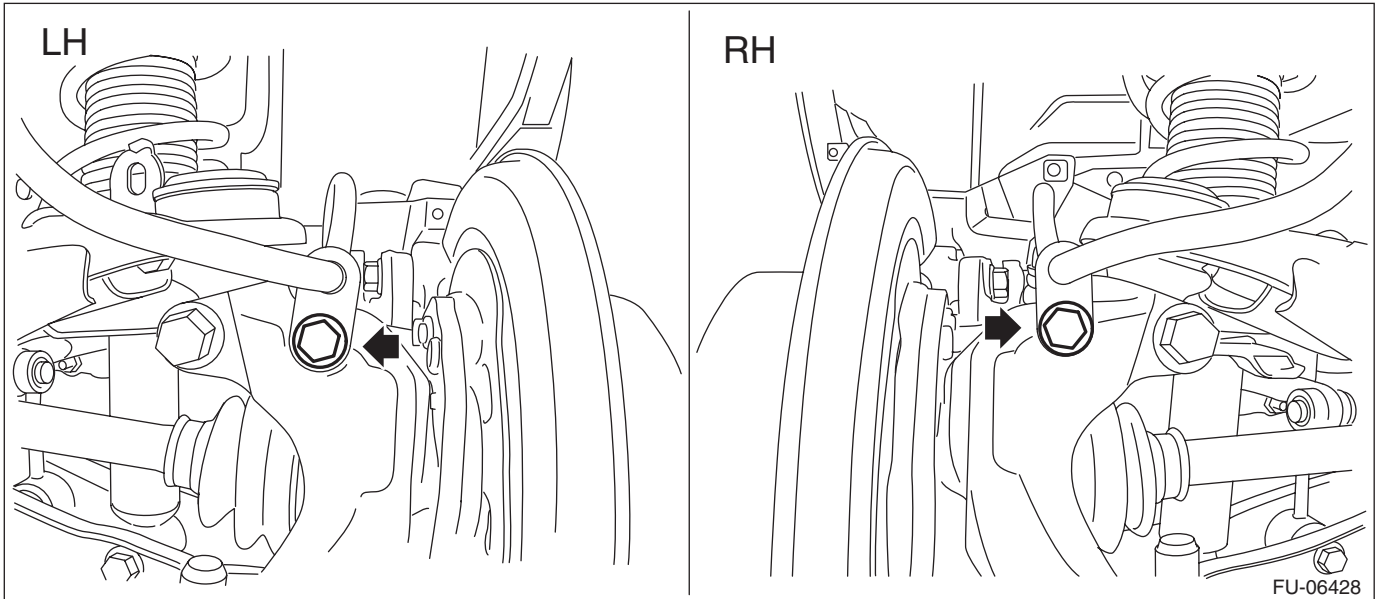

FU-06428

Fuel Filler Pipe

FUEL INJECTION (FUEL SYSTEMS)

16) Install the rear ABS wheel speed sensor harness to the upper arm.

NOTE:

Prevent the harness identification (line) from being twisted when installing. (RH: Orange line, LH: Green line)

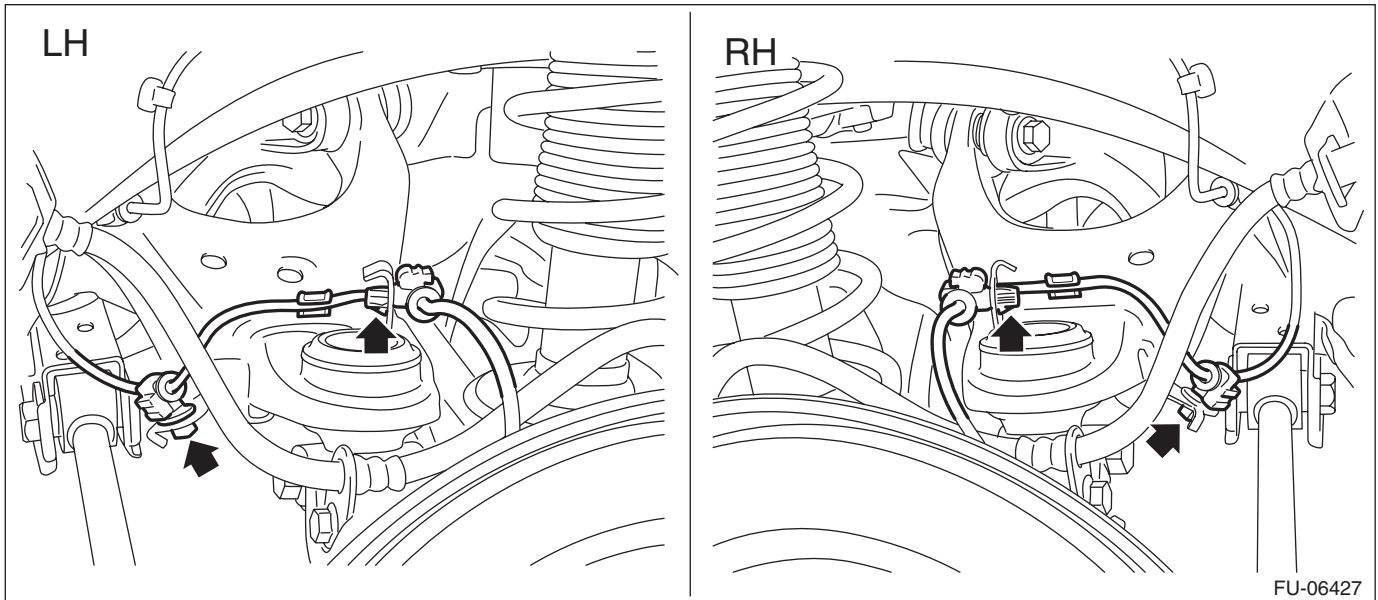

17) Attach the rear ABS wheel speed sensor to the rear housing.

NOTE:

Prevent the harness identification (line) from being twisted when installing. (RH: Orange line, LH: Green line)

Tightening torque:

7.5 N·m (0.8 kgf-m, 5.5 ft-lb)

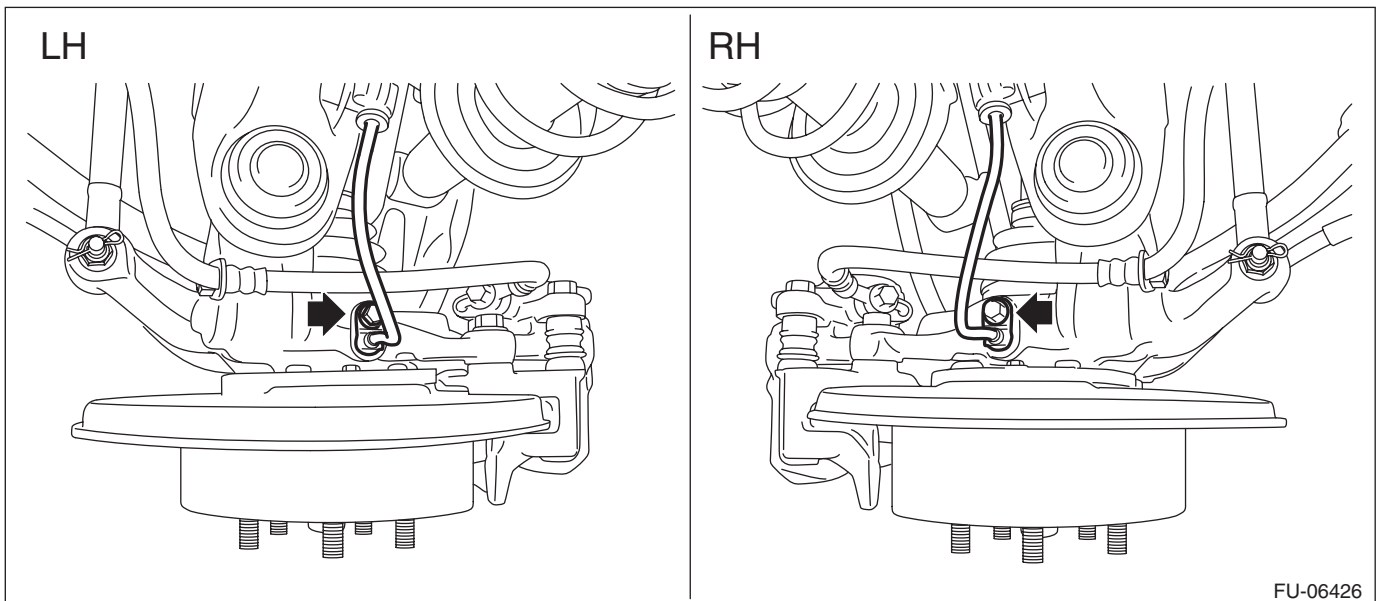

18) Lower the vehicle.

19) Install the rear wheels.

Tightening torque:

120 N·m (12.2 kgf-m, 88.5 ft-lb)

20) Connect the battery ground terminal.

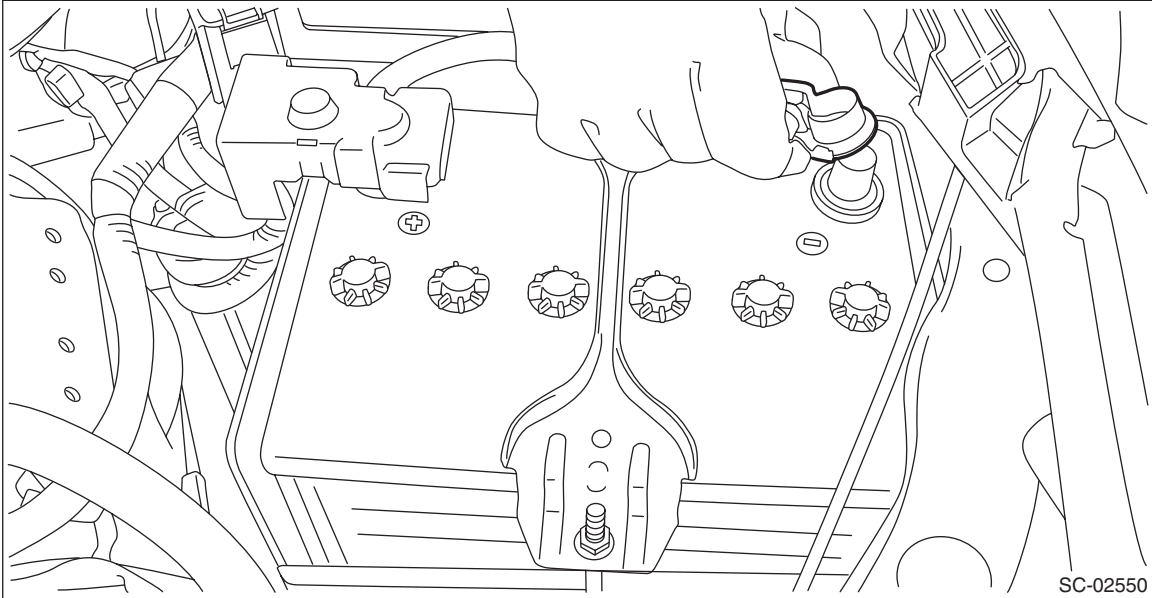

21) Inspect the wheel alignment and adjust if necessary.

22) Perform reinitialization of the auto headlight beam leveler system. (Model with auto headlight beam leveler) <Ref. to LI-17, PROCEDURE, Auto Headlight Beam Leveler System.>

C: INSPECTION

- 1) Check that the fuel filler pipe assembly has no deformation, cracks or other damages.
- 2) Check that the fuel hose has no cracks, damage or loose part.