

Windshield Glass

GLASS/WINDOWS/MIRRORS

15. Windshield Glass

A: REMOVAL

1. USING WINDSHIELD GLASS KNIFE

- 1) Disconnect the ground cable from battery. (Models with wiper deicer)
- 2) Remove the trim panel - front pillar UPR. <Ref. to EI-100, REMOVAL, Upper Inner Trim.>
- 3) Remove the cowl panel assembly. <Ref. to EI-53, REMOVAL, Cowl Panel.>
- 4) Disconnect the wiper deicer connector. (Models with wiper deicer)
- 5) Remove the molding - front window from the glass - front window, and attach protective tape on the body side of the circumference of the glass - front window.

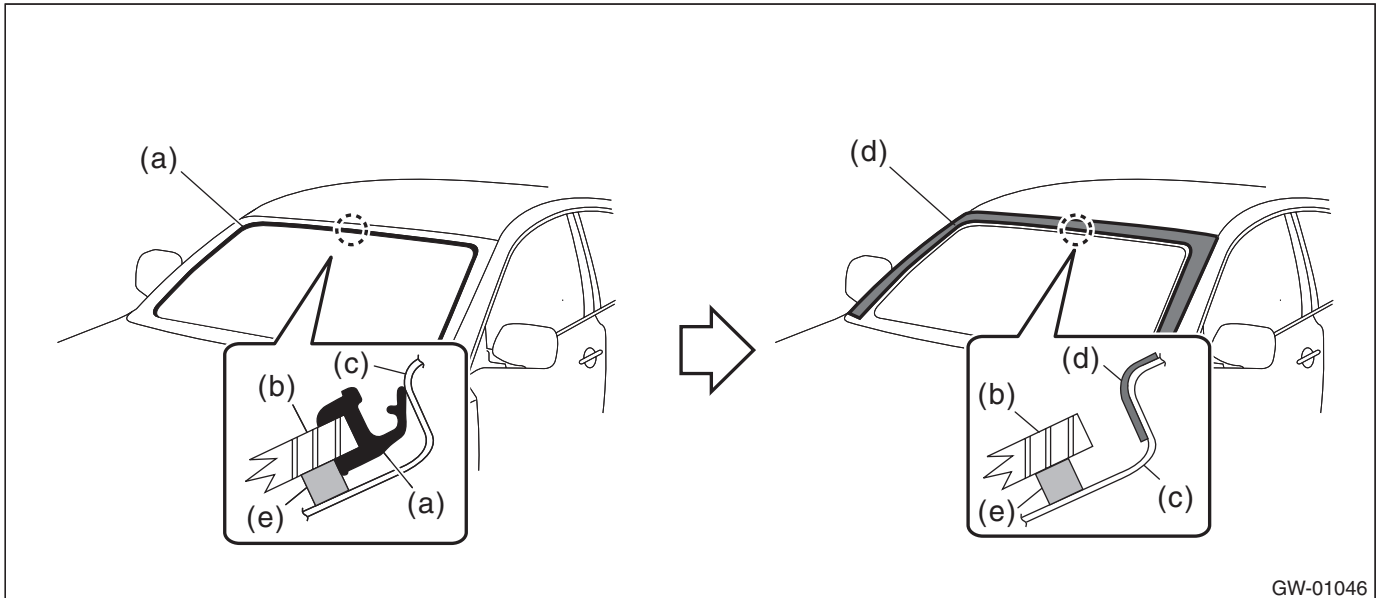

(a) Molding - front window

(b) Glass - front window

(c) Body panel

(d) Protective tape

(e) Adhesive

6) Remove the glass - front window.

- (1) Apply sufficient amount of soapy water to the adhesive part and insert the windshield glass knife.
- (2) While holding the edges of the knife and the glass - front window at a right angle, move the windshield glass knife parallel to the edge of the glass - front window, and cut the adhesive along the surface and the edge of the glass - front window.

CAUTION:

- Cutting of adhesive part should be started from an area with wider gap between the glass - front window and the body.
- Never twist the windshield glass knife.

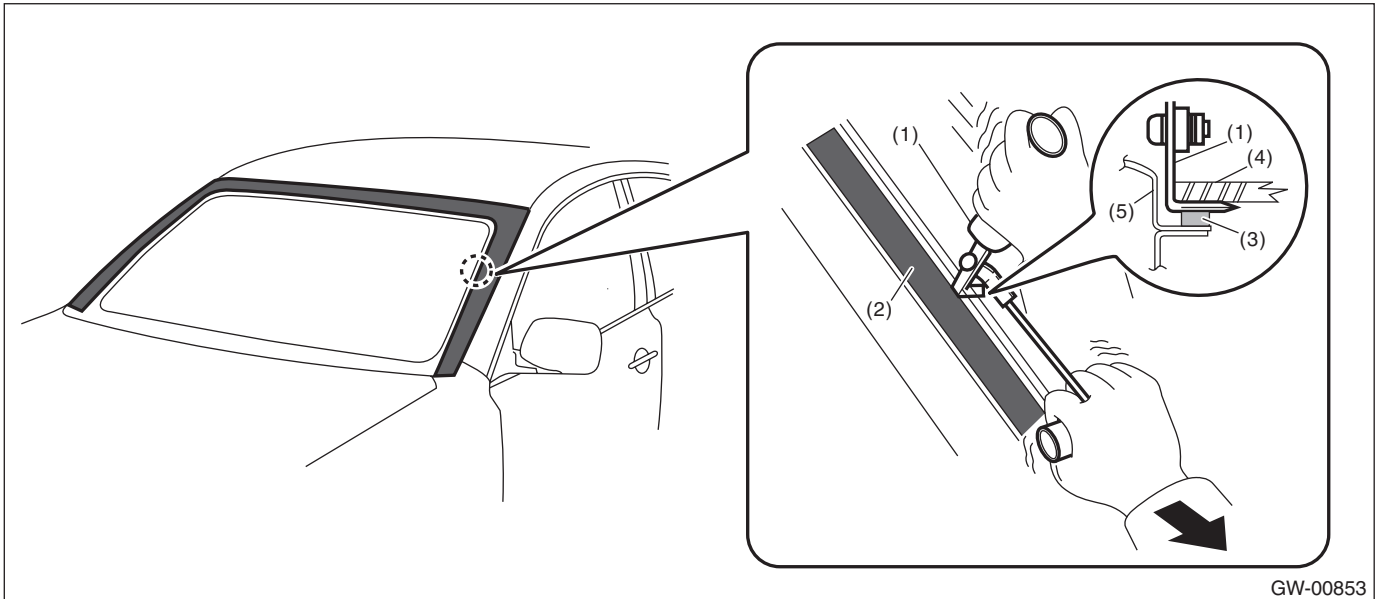

GW-00853

- | | | |
|----------------------------|--------------------------|----------------|
| (1) Windshield glass knife | (3) Adhesive | (5) Body panel |
| (2) Protective tape | (4) Glass - front window | |

(3) Disconnect the locating pin - front window, and remove the glass - front window.

NOTE:

The locating pin - front window are bonded to the corners of the glass - front window. Use piano wire to disconnect the pins.

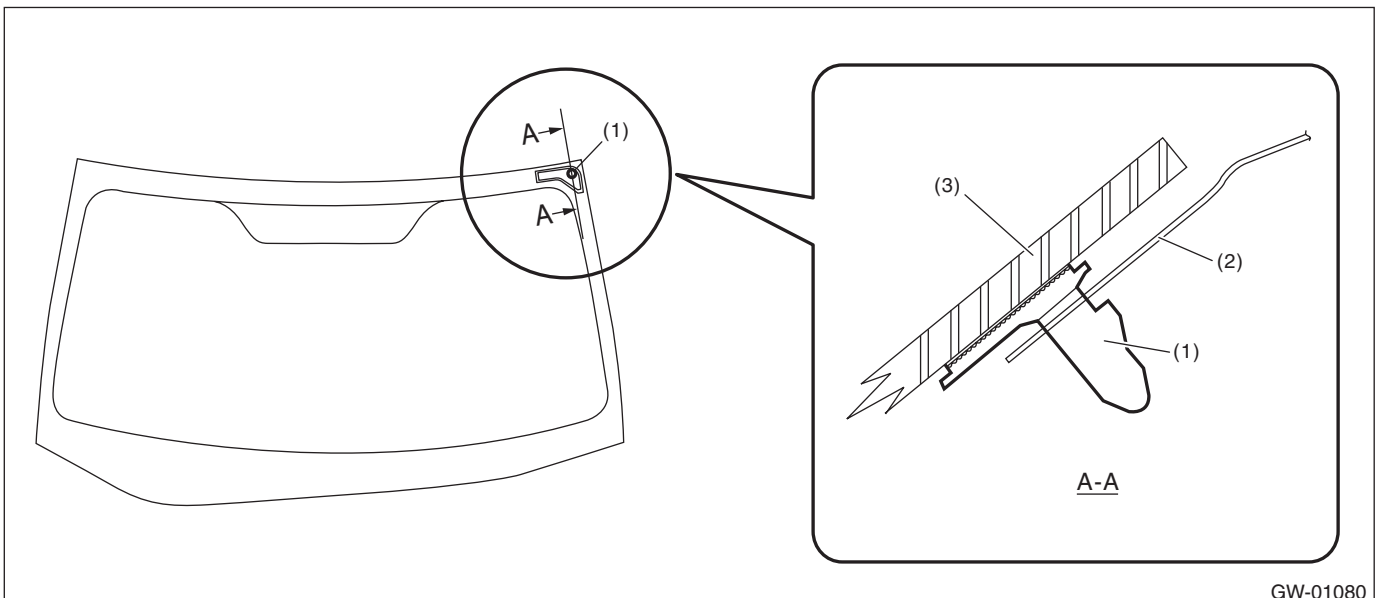

GW-01080

- | | | |
|---------------------------------|----------------|--------------------------|
| (1) Locating pin - front window | (2) Body panel | (3) Glass - front window |
|---------------------------------|----------------|--------------------------|

Windshield Glass

GLASS/WINDOWS/MIRRORS

2. USING PIANO WIRE

CAUTION:

- Do not tightly pull the piano wire against the glass - front window edge.
- Apply protective tape, etc, and be careful that the inner and outer components of the vehicle are not damaged.

- Do not cross piano wires. Otherwise they may be cut.

- 1) Disconnect the ground cable from battery. (Models with wiper deicer)
- 2) Remove the trim panel - front pillar UPR. <Ref. to EI-100, REMOVAL, Upper Inner Trim.>
- 3) Remove the cowl panel assembly. <Ref. to EI-53, REMOVAL, Cowl Panel.>
- 4) Disconnect the wiper deicer connector. (Models with wiper deicer)
- 5) Remove the molding - front window from the glass - front window, and attach protective tape on the body side of the circumference of the glass - front window.

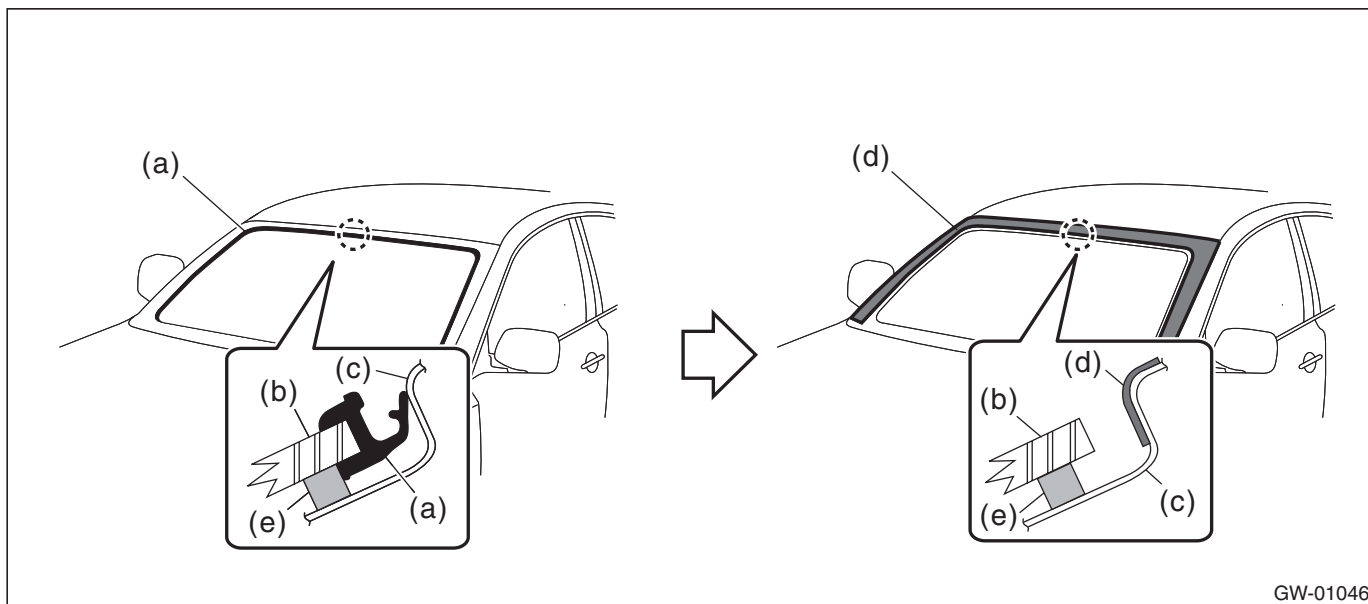

GW-01046

(a) Molding - front window
(b) Glass - front window

(c) Body panel
(d) Protective tape

(e) Adhesive

6) Remove the glass - front window.

(1) Using a drill, make a hole in the adhesive part.

(2) Pass the piano wire through the hole, and pull the wire ends alternately to cut off the adhesive part and the locating pin - front window.

CAUTION:

Attach a piece of wood to both piano wire ends.

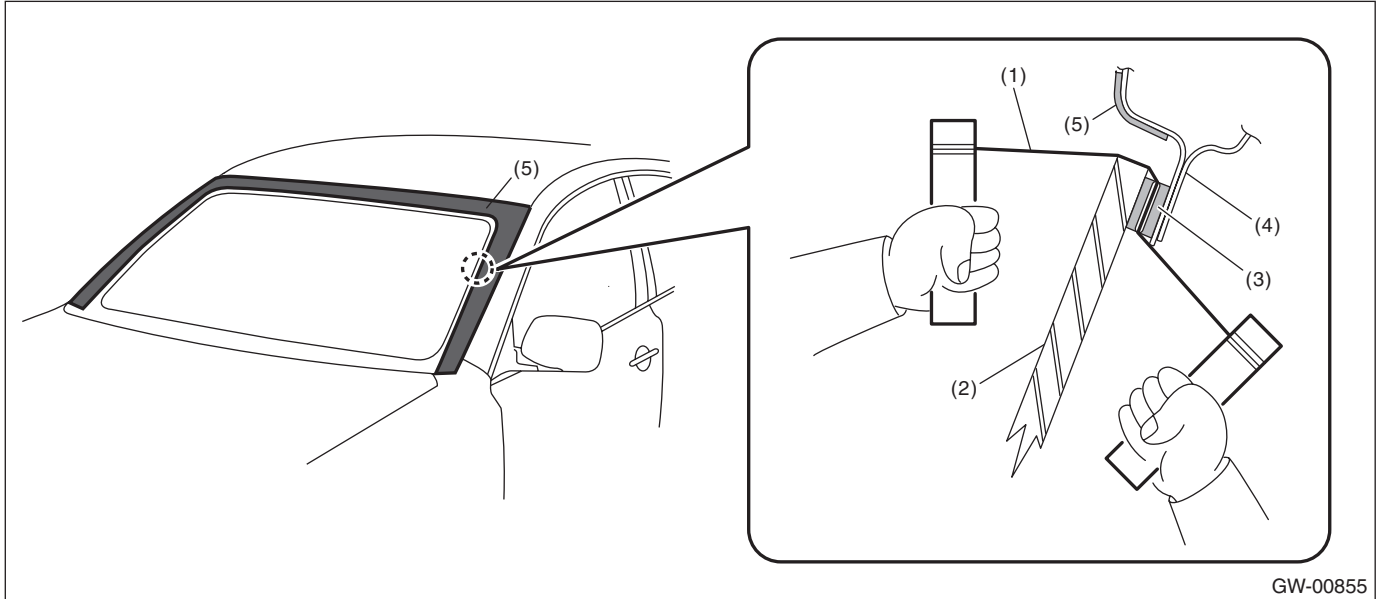

GW-00855

- (1) Piano wire
- (2) Glass - front window

- (3) Adhesive
- (4) Body panel

- (5) Protective tape

Windshield Glass

GLASS/WINDOWS/MIRRORS

B: INSTALLATION

1) Fabricate the cartridge nozzle tip as shown and set the sealant gun with the adhesive.

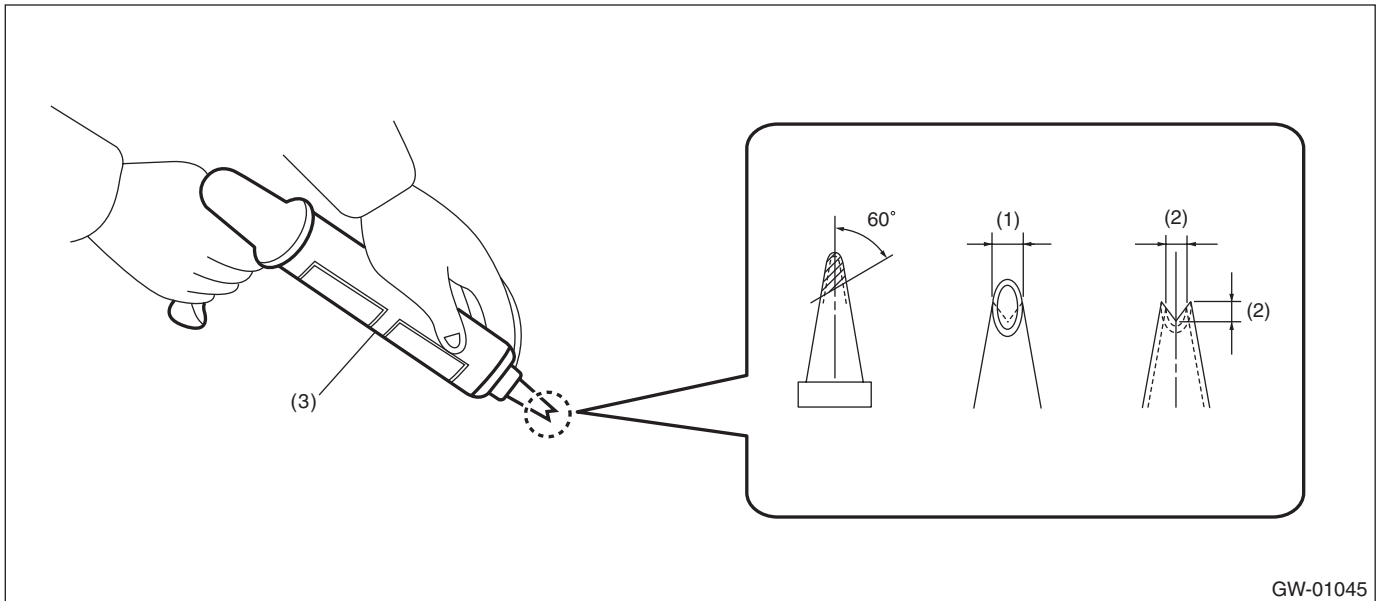

(1) 10 mm (0.39 in)

(2) 8 mm (0.31 in)

(3) Sealant gun

2) Remove the adhesive layer on the body using cutter knife to obtain smooth face of 2 mm (0.08 in) thick.

CAUTION:

- Be careful not to damage the body and paint surface.
- Be sure to keep some of old adhesive.

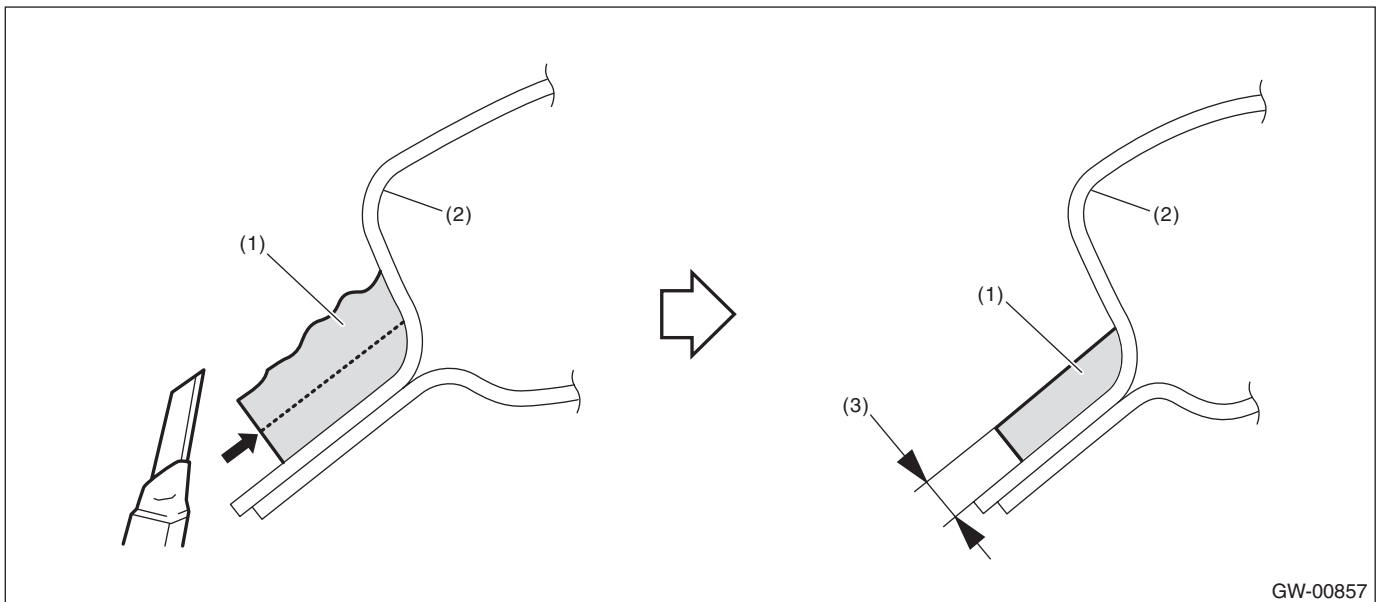

(1) Adhesive

(2) Body panel

(3) 2 mm (0.08 in)

3) Clean the glass - front window and the body with alcohol or white gasoline to completely eliminate cutting powder, dust and dirt.

4) Attach the dam rubber - front to the glass - front window.

NOTE:

Adhere the dam rubber along with the ceramic print.

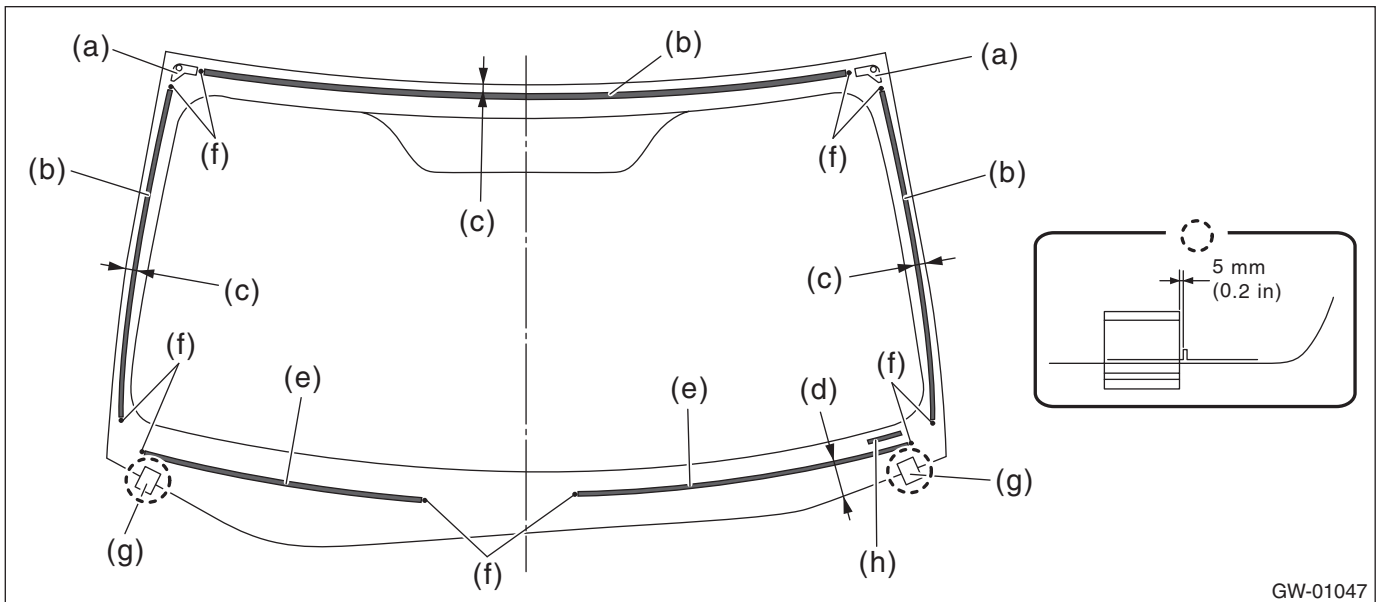

GW-01047

- | | | |
|---------------------------------|------------------------------|----------------------|
| (a) Locating pin - front window | (d) 14.1 mm (0.56 in) | (g) Seal - lower |
| (b) Dam rubber - front upper | (e) Dam rubber - front lower | (h) Seal - lower VIN |
| (c) 16 mm (0.63 in) | (f) Ceramic print | |

5) Attach the molding - front window to the glass - front window.

CAUTION:

Be careful to attach the molding - front window so that the molding has no loose or undulating part.

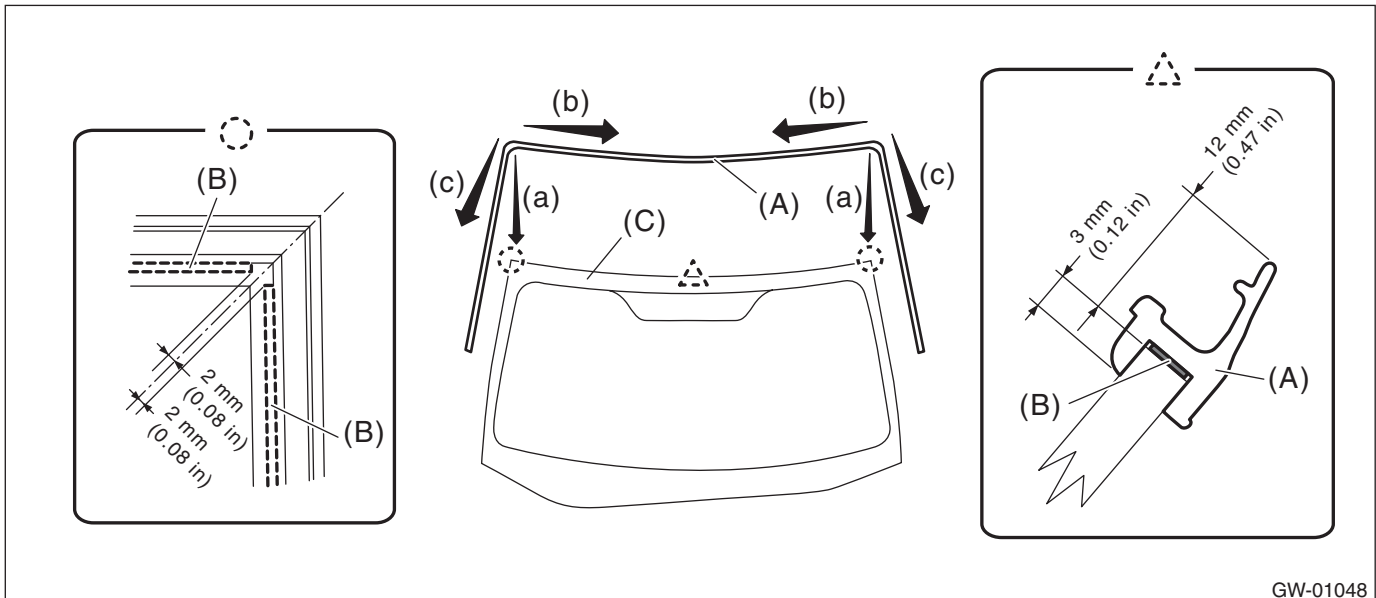

GW-01048

- (1) Align the molding - front window (A) to the upper ends (a) of the glass - front window (C).
- (2) Install the molding - front window from both corners of the upper edge toward the center (b).
- (3) Install the molding - front window from both corners of the upper edge toward the lower side (c).
- (4) Firmly apply the double sided tape (B) of the molding - front window evenly to the surface of the glass - front window.

Windshield Glass

GLASS/WINDOWS/MIRRORS

6) Install the glass - front window.

(1) Apply the primer to the adhesive surface of glass - front window side and body side using sponge.

Glass primer:

Dow Automotive's

ESSEX U-401, U-402 or equivalent

Painted surface primer:

Dow Automotive's

ESSEX U-413 or equivalent

NOTE:

- Primer once attached to the painted surface of the body and internal trim is hard to wipe off. Mask the circumference of such area.

- Let primer dry for about ten minutes before installing the glass - front window.

- Do not touch the surface coated with primer.

(2) Apply adhesive to the end back surface of the glass - front window.

Adhesive:

Dow Automotive's

ESSEX U-400HV or equivalent

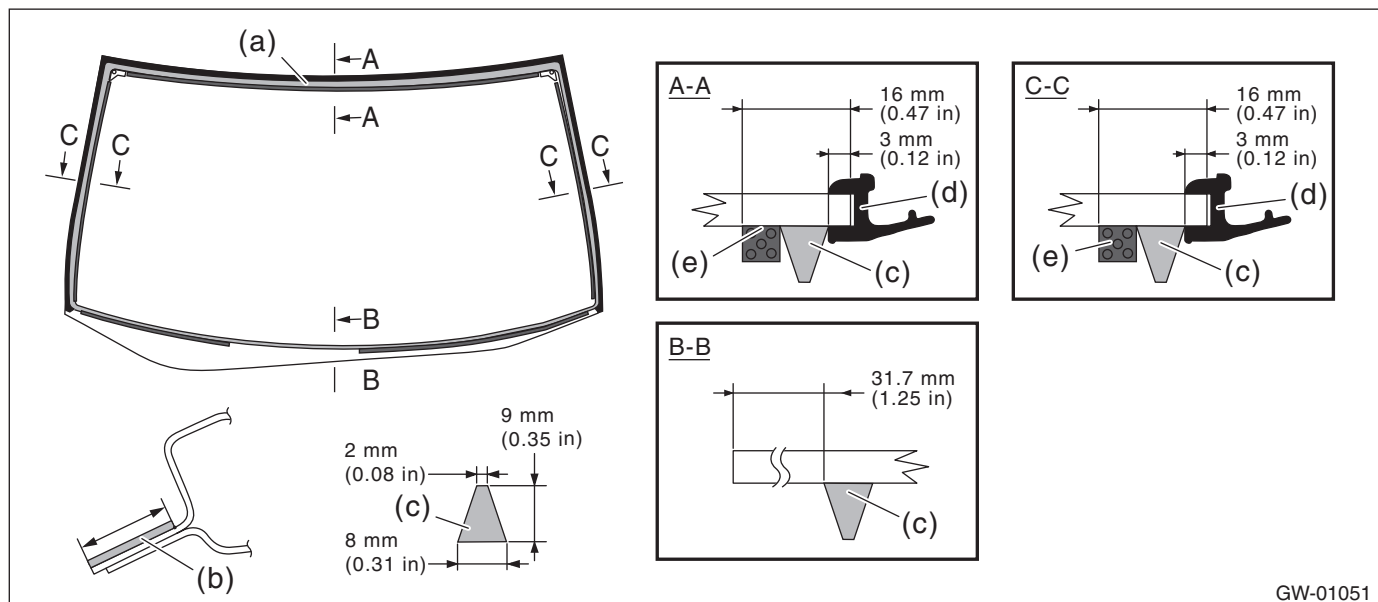

(a) Application of primer (glass side)

(c) Adhesive

(e) Dam rubber - front

(b) Application of primer (body side)

(d) Molding - front window

(3) Fit the locating pins - front window to the vehicle body using suction rubber cups to install the windshield glass.

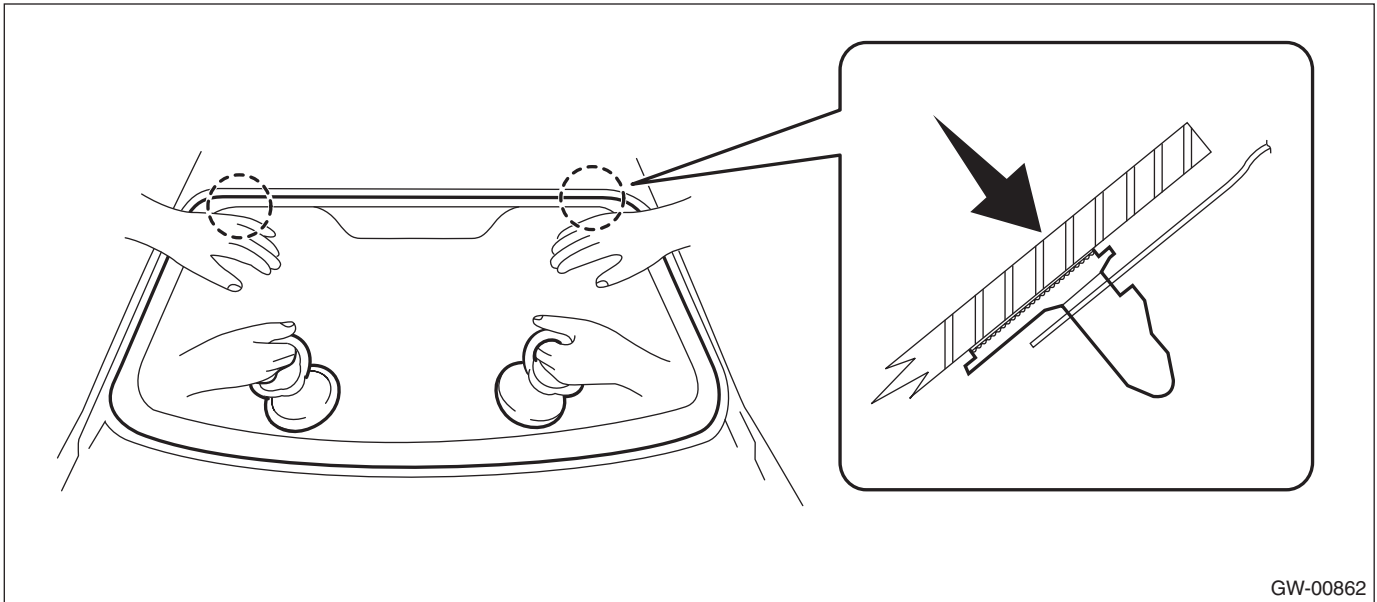

GW-00862

(4) Lightly press the entire perimeter of the glass - front window for tight fit.

(5) Make flush the adhesive surface jugged out using spatula.

7) After completion of all work, allow the vehicle to stand for about 24 hours.

NOTE:

- When opening/closing the door after the glass - front window was bonded, always lower the glass assembly - door first, and then open/close it carefully.
- Move the vehicle slowly.
- For minimum drying time and vehicle standing time before driving after bonding, follow instructions or instruction manual from the adhesive manufacturer.

8) Connect the wiper deicer connector. (Models with wiper deicer)

9) Install the cowl panel assembly. <Ref. to EI-54, INSTALLATION, Cowl Panel.>

10) Install the trim panel - front pillar UPR. <Ref. to EI-104, INSTALLATION, Upper Inner Trim.>

11) Connect the battery ground terminal. (Models with wiper deicer)

12) After curing of adhesive, pour the water on external surface of vehicle to check that there are no water leaks.

NOTE:

When a vehicle is returned to the user, tell him or her that the vehicle should not be subjected to heavy impact for at least three days.