

Rear Window Glass

GLASS/WINDOWS/MIRRORS

16.Rear Window Glass

A: REMOVAL

- 1) Disconnect the ground cable from battery.
- 2) Disconnect the rear defogger connector.
- 3) Remove the glass - rear window in the same procedure as for the glass - front window. <Ref. to GW-38, REMOVAL, Windshield Glass.>

B: INSTALLATION

- 1) Fabricate the cartridge nozzle tip as shown and set the sealant gun with the adhesive.

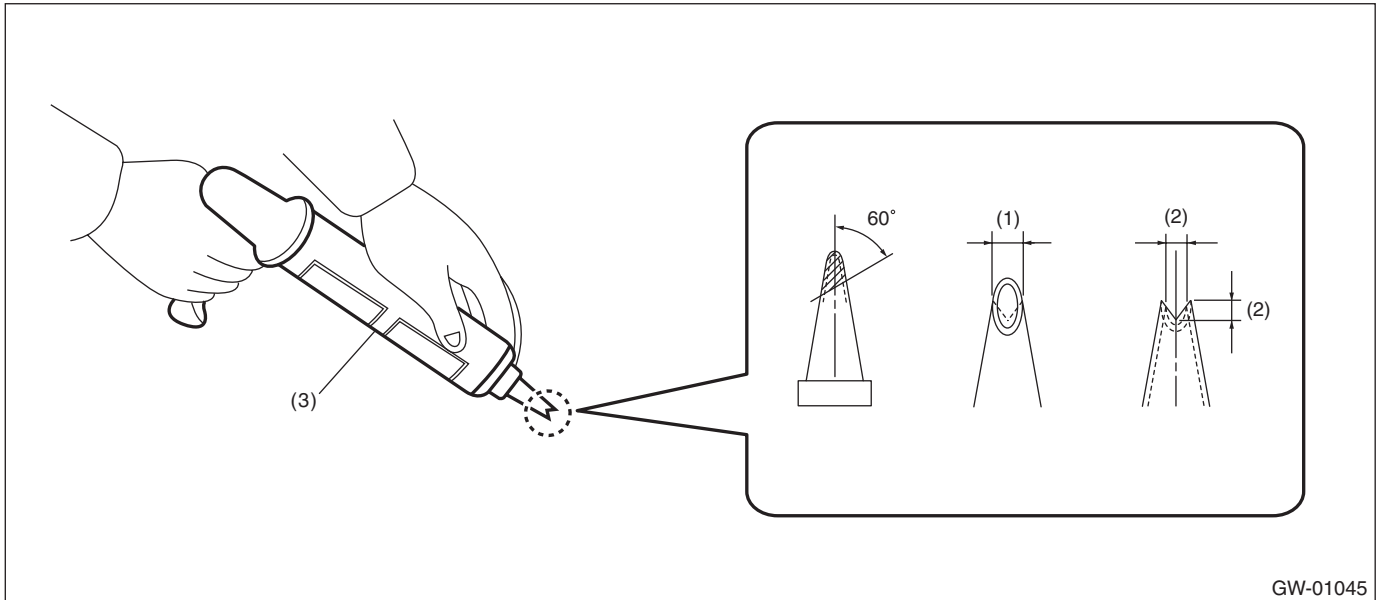

(1) 10 mm (0.39 in)

(2) 8 mm (0.31 in)

(3) Sealant gun

- 2) Smoothen and clean the adhesive surfaces of the glass - rear window and body using the same procedures as for the glass - front window. <Ref. to GW-42, INSTALLATION, Windshield Glass.>

- 3) Attach the dam rubber - rear to the glass - rear window.

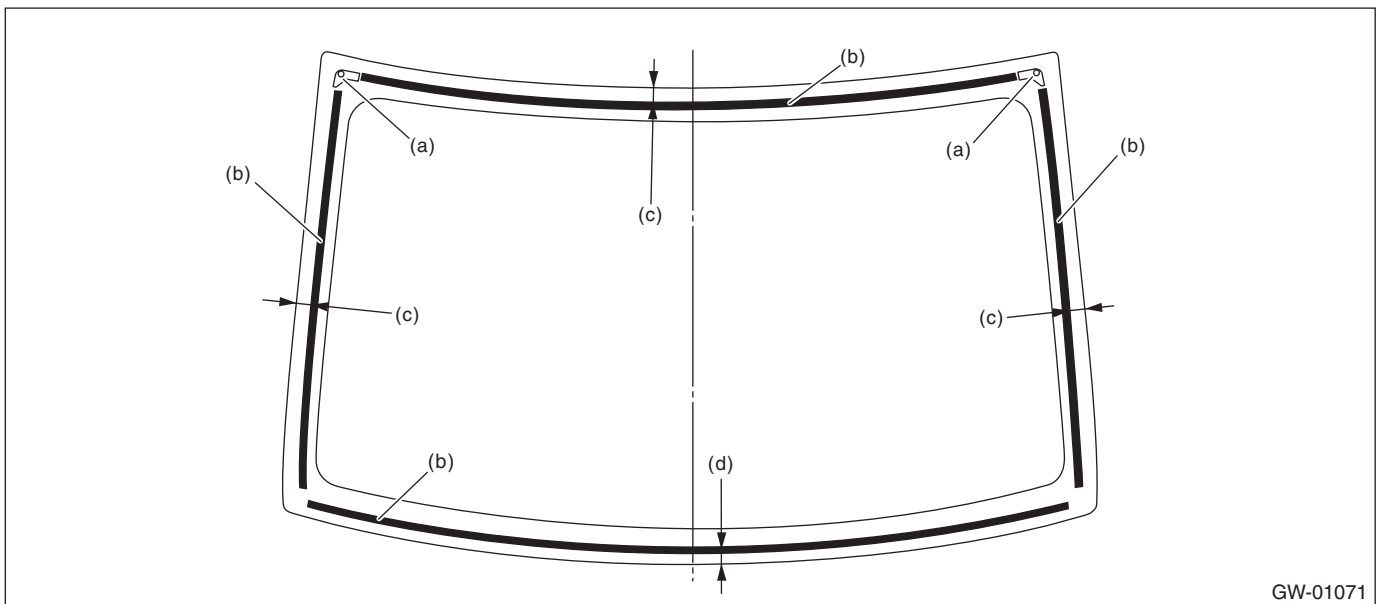

(a) Locating pin - rear window

(c) 20.9 mm (0.82 in)

(d) 10.7 mm (0.42 in)

(b) Dam rubber - rear

Rear Window Glass

4) Attach the molding - rear window to the glass - rear window.

CAUTION:

Be careful to attach the molding - rear window so that the molding has no loose or undulating part.

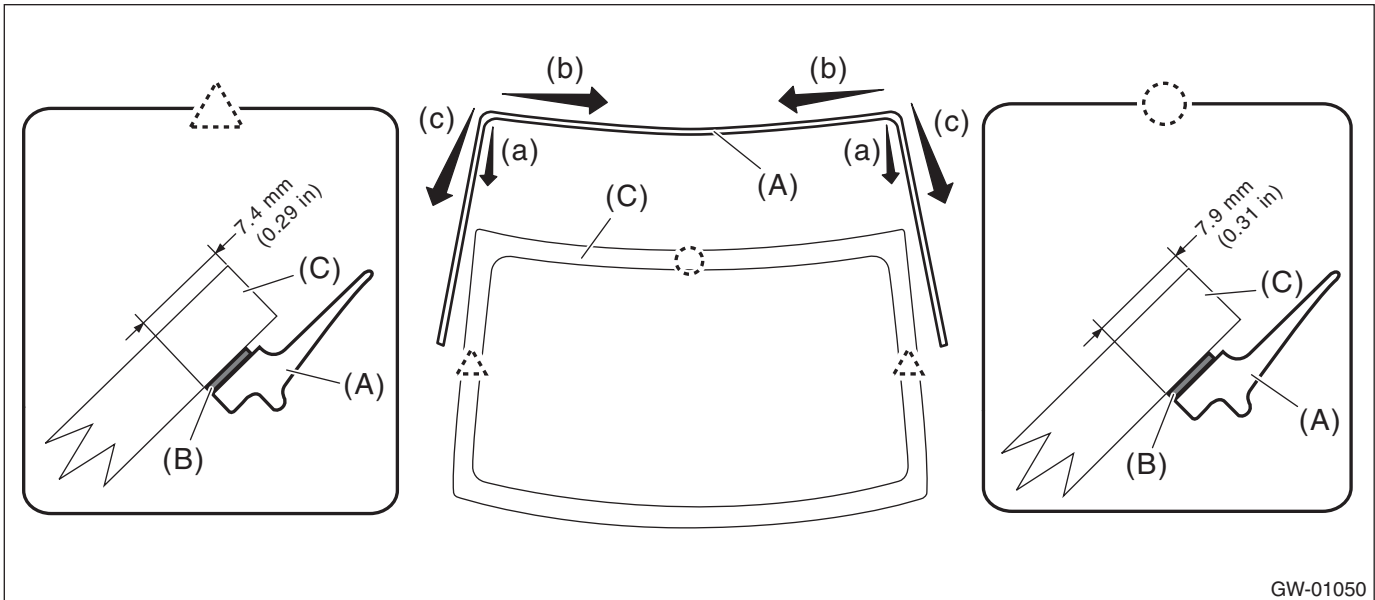

GW-01050

- (1) Align the molding - rear window (A) to the upper ends (a) of the glass - rear window (C).
- (2) Install the molding - rear window from both corners of the upper edge toward the center (b).
- (3) Install the molding - rear window from both corners of the upper edge toward the lower side (c).
- (4) Firmly apply the double sided tape (B) of the molding - rear window evenly to the surface of the glass - rear window.

5) Install the glass - rear window in the same procedure as for the glass - front window. <Ref. to GW-42, INSTALLATION, Windshield Glass.>

- (1) Apply the primer to the adhesive surface of glass - rear window side and body side using sponge.
- (2) Apply adhesive to the end back surface of the glass - rear window.

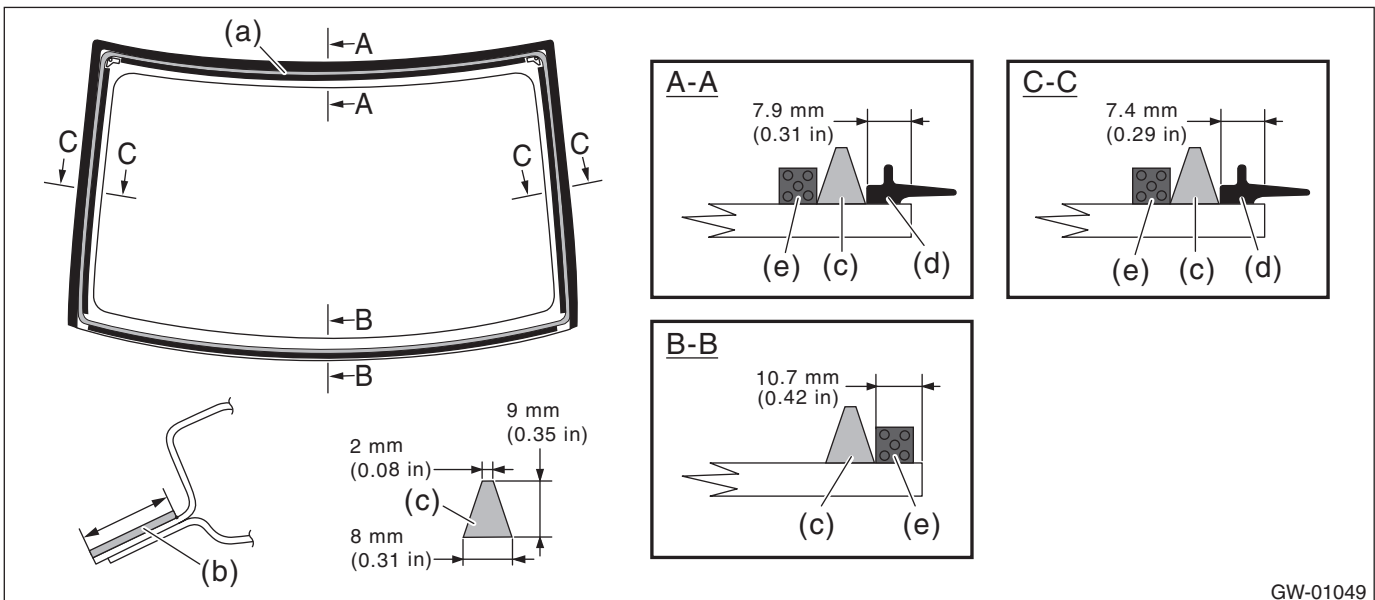

GW-01049

- | | | |
|--|---------------------------|-----------------------|
| (a) Application of primer (glass side) | (c) Adhesive | (e) Dam rubber - rear |
| (b) Application of primer (body side) | (d) Molding - rear window | |

- (3) Insert the locating pins - rear window into the rear panel holes, and install the glass - rear window.
- (4) Lightly press the entire perimeter of the glass - rear window for tight fit.

Rear Window Glass

GLASS/WINDOWS/MIRRORS

(5) Make flush the adhesive surface juttred out using spatula.

6) After completion of all work, allow the vehicle to stand for about 24 hours.

NOTE:

- When opening/closing the door after the glass - rear window was bonded, always lower the glass assembly - door first, and then open/close it carefully.
- Move the vehicle slowly.
- For minimum drying time and vehicle standing time before driving after bonding, follow instructions or instruction manual from the adhesive manufacturer.

7) Connect the rear defogger connector.

8) After curing of adhesive, pour the water on external surface of vehicle to check that there are no water leaks.

NOTE:

When a vehicle is returned to the user, tell him or her that the vehicle should not be subjected to heavy impact for at least three days.