

Rear Window Defogger System

GLASS/WINDOWS/MIRRORS

18.Rear Window Defogger System

A: WIRING DIAGRAM

Refer to “Rear Defogger System” in the wiring diagram. <Ref. to WI-122, WIRING DIAGRAM, Rear Defogger System.>

B: INSPECTION

1. CHECK SYSTEM

Symptoms	Inspection order
Rear window defogger does not operate.	<ol style="list-style-type: none">1. Check the fuse.2. Check the rear defogger relay.3. Check the rear window defogger switch.4. Check the heat wire.5. Check the wiring harness.6. Check body integrated unit.

NOTE:

Rear window defogger system can be customized using the Subaru Select Monitor, when the customize setting {Auto A/C ECU Setting} of the body integrated unit is set to {support}.

System name	Initial setting	Customize setting
Rear defogger operation mode	OFF after 15 min.	Repeat 15 min. operation and 2 min. stop.

2. CHECK WITH SUBARU SELECT MONITOR

CAUTION:

Check whether the Rr Defogger op. mode setting is in initial setting or customize setting before performing inspection.

- 1) Check the input signal when the rear window defogger switch is operated using Subaru Select Monitor.
 - (1) Prepare the Subaru Select Monitor. <Ref. to GW-7, PREPARATION TOOL, General Description.>
 - (2) Turn the ignition switch to ON (engine OFF) and run the “PC application for Subaru Select Monitor”.
 - (3) On «System Selection Menu» display, select {Integ. unit mode}.
 - (4) Select {Auto A/C ECU Setting} from Current Data Display & Save.
 - (5) Check the vehicle equipment and the settings of body integrated unit.
 - Model with manual A/C: Without auto A/C ECM setting
 - Model with auto A/C: With auto A/C ECM settingIf correct, go to (6).
If not correct, go to (8).
 - (6) Select the {Rr Defogger output} on {Current Data Display & Save}.
 - (7) Check the displayed data (ON/OFF) by operating the rear window defogger switch.
 - (8) On the system selection menu display, select the body integrated unit mode. Select customize from work support, then select {Auto A/C ECU Setting}. Match the auto A/C ECM setting to the actual vehicle equipment.
- 2) Check the operation with rear window defogger switch ON.
 - When customize setting is set as “Continuous”, it is normal if the 15-minute operation and 2-minute stop repeats.
 - When customize setting is “Normal”, it is normal if the operation lasts for 15 minutes and then turns OFF.
- 3) When the operation in 2) above fails, replace the body integrated unit.

3. HEAT WIRE INSPECTION

CAUTION:

Use a dry soft cloth to wipe off dirt on the glass along the heat wires with care not to damage the heat wires.

1) Prepare the following checking items.

- Liquid crystal thermograph sheet (Approximate Size: 300 × 300 mm (11.8 × 11.8 in) and thermal temperature: 35 — 40°C (95 — 104°F))
 - Aluminum foil
- 2) Turn the ignition switch to ON.
 3) Turn the defogger switch to ON.
 4) Push the liquid crystal thermograph sheet from the outside of the glass - rear window.

NOTE:

Use the liquid crystal thermograph sheet every range it is separated with the separate line.

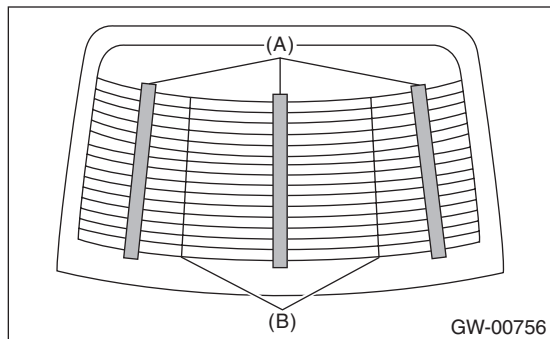

- (A) Liquid crystal thermograph sheet
 (B) Separate line

5) Determine the faulty heat wire by checking the color of the liquid crystal thermograph sheet.

Liquid crystal thermograph sheet	Criteria
Change occurred (red → blue)	Normal
No change (black)	Open

NOTE:

- Check from the inside of the glass - rear window if the liquid crystal thermograph sheet does not change.
 - The time for the color change may differ depends on the surface temperature of the glass.
- 6) Wrap a piece of aluminum foil around the tip of tester probe and press it against the heat wire with your finger.

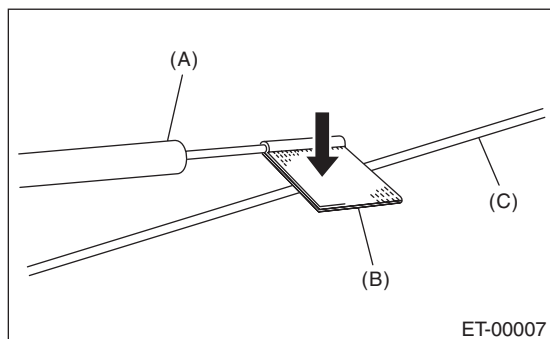

- (A) Tester probe
 (B) Aluminum foil
 (C) Heat wire

7) To both ends of the section that has been found to include an open in the step 5), apply the tester positive (+) probe and the negative (-) probe.

Rear Window Defogger System

GLASS/WINDOWS/MIRRORS

8) Move the tester probe on the negative (-) side slowly along the heat wire. If voltage changes from zero while moving the tester probe, heat wire is open at the voltage change point.

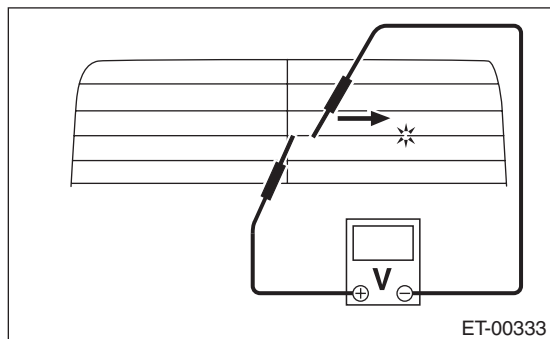

9) Repair the heat wire that determines the place of the open circuit. <Ref. to GW-54, REPAIR, Rear Window Defogger System.>

C: REPAIR

- 1) Clean the broken portion with alcohol or white gasoline.
- 2) Mask both side of wire with masking tape.
- 3) Apply the conductive silver composition to the broken portion.

Conductive silver composition:
by Permatex
QUICK GRID

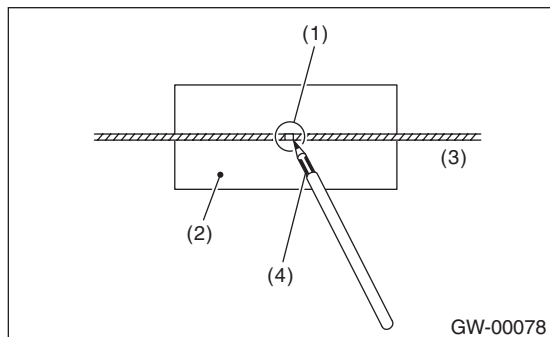

- (1) Broken portion
- (2) Masking tape
- (3) Broken wire
- (4) Conductive silver composition

- 4) Dry using a dryer after applying the composition.
- 5) After repair, check the wire.