

General Description

INSTRUMENTATION/DRIVER INFO

1. General Description

A: SPECIFICATION

1. COMBINATION METER ASSEMBLY

Meter, display	Operation method, display method	Drive control	When checking the indicator needle operation/needle reading operation
Speedometer	Stepping motor type	Combination meter	—
Tachometer			
ECO gauge			
ABS warning light	LED	Combination meter	On/Off
STEERING warning light			
AT oil temperature warning light			
Driver's seat belt warning light			
Door warning light			
Tire pressure warning light (U.S. model)			
AWD warning light (AT model)			
Hill start assist warning light			
VDC warning light / VDC operation indicator light			
VDC OFF indicator light			
High beam indicator light			
Front fog light indicator light			
Lighting indicator light			
Fuel level warning light			
Malfunction indicator light			
Airbag warning light			
Engine oil level warning light			
Washer fluid level warning light			
Meter illumination back light			
LCD back light			Light ON
Engine coolant temperature warning light (red)			On (red)/Off
Engine coolant temperature indicator light (blue)			Off/On (blue)
Oil pressure warning light		Oil pressure switch	Turns on or off according to module control
Charge warning light	Generator		
Turn signal indicator light	Turn signal and hazard unit		
Security/immobilizer indicator light	Body integrated unit		
Auto leveler warning light (model with HID)	Auto headlight beam leveler CM		
Parking brake/brake fluid level warning light	Combination meter/ brake fluid level switch	On/Turns on or off according to module control	
Odo indicator	LCD	Combination meter	—
Trip indicator			
Shift indicator			
AT select lever position indicator			
FUEL meter			
CRUISE indicator			
CRUISE SET indicator			
SPORT indicator			

General Description

2. MULTI-FUNCTION DISPLAY

- Standard type

Display	Display method
Average/instantaneous fuel economy, cruising distance, ambient temperature, current time, continuous driving time, average vehicle speed	LCD
Passenger's seat airbag indicator light	LED
Passenger's airbag ON indicator light	
Passenger's airbag OFF indicator light	
Passenger's seat belt warning light	

- High grade type

Display	Display method
Fuel economy screen, ecology evaluation screen, preventive safety screen, clock/ambient temperature, self-check screen, information screen	TFT
Air conditioner display	LCD
Passenger's seat airbag indicator light	LED
Passenger's airbag ON indicator light	
Passenger's airbag OFF indicator light	
Passenger's seat belt warning light	

General Description

INSTRUMENTATION/DRIVER INFO

B: LOCATION

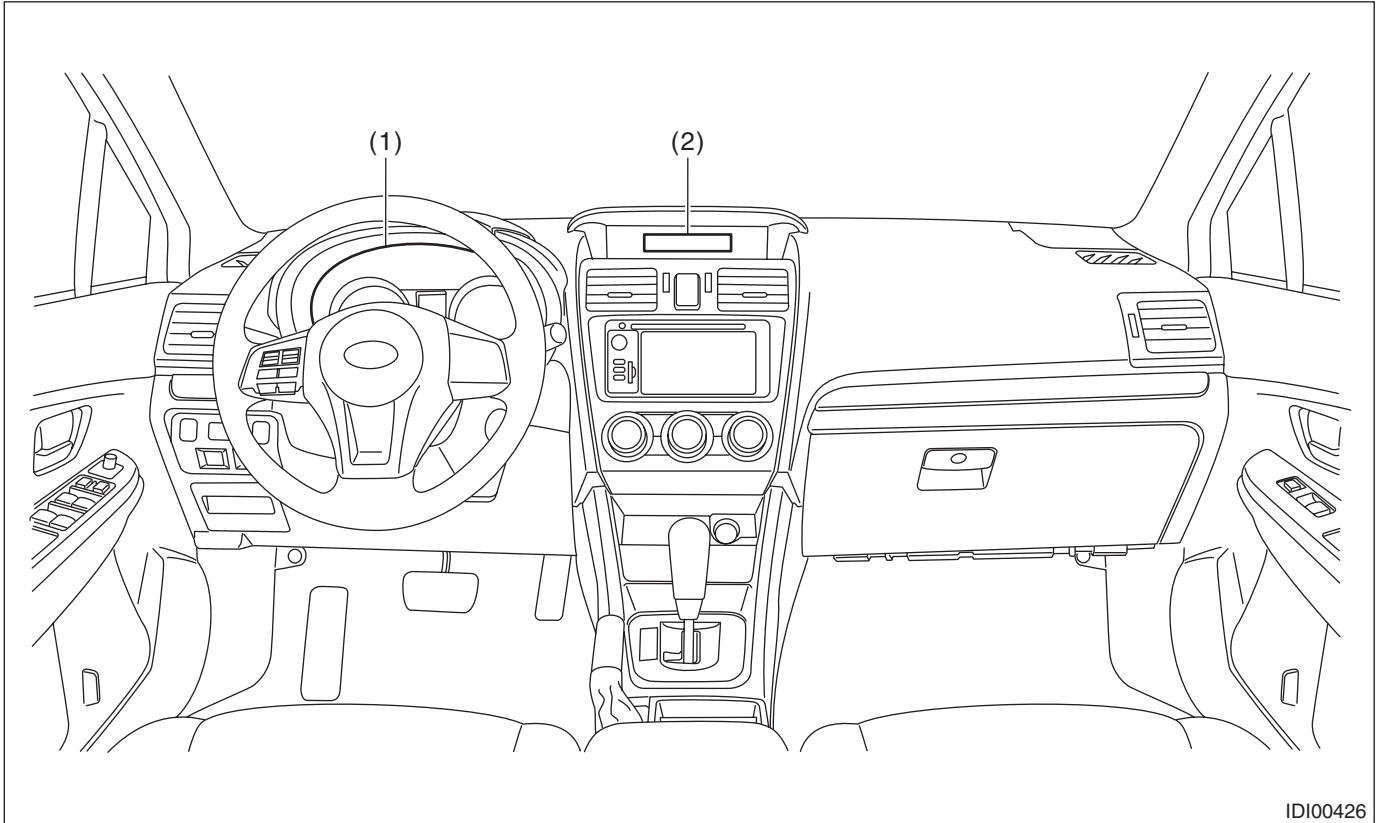

IDI00426

(1) Combination meter ASSY

(2) Multi-function display

C: CAUTION

- Before disassembling or reassembling parts, always disconnect the battery ground cable from battery. When replacing the audio, control module and other parts provided with memory functions, record the memory contents before disconnecting the battery ground cable. Otherwise, the memory is cleared.
- Reassemble the parts in the reverse order of disassembly procedure unless otherwise indicated.
- Use gloves to avoid damage and getting fingerprints on the glass surface and meter surfaces.
- Do not apply an excessive force on the printed circuit.
- Do not drop or otherwise apply impact.
- Connect the connectors securely during reassembly.
- After reassembly, make sure that each component operates normally.
- When the combination meter assembly has been replaced, be sure to perform the registration of immobilizer.
- If the steering wheel and steering angle sensor (steering roll connector) are removed, perform “VDC sensor midpoint setting mode” of the VDC. <Ref. to VDC-19, VDC SENSOR MIDPOINT SETTING MODE, ADJUSTMENT, VDC Control Module and Hydraulic Control Unit (VDCCM&H/U).>

D: PREPARATION TOOL

1. SPECIAL TOOL

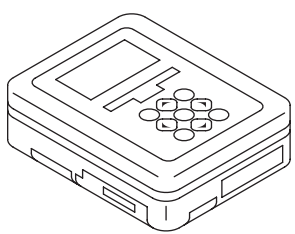
ILLUSTRATION	TOOL NUMBER	DESCRIPTION	REMARKS
 ST1B022XU0	1B022XU0	SUBARU SELECT MONITOR III KIT	Used for setting of each function and troubleshooting for electrical system. NOTE: For detailed operation procedures of SUBARU SELECT MONITOR III KIT, refer to “PC application help for Subaru Select Monitor”.

2. GENERAL TOOL

TOOL NAME	REMARKS
Circuit tester	Used for measuring resistance and voltage.
Steering wheel puller	Used for removing the steering wheel.