

5. Combination Meter

A: REMOVAL

- 1) Disconnect the ground cable from battery.
- 2) Release the lock, tilt the steering column to the lowest end and fully extend the column by the telescopic system.

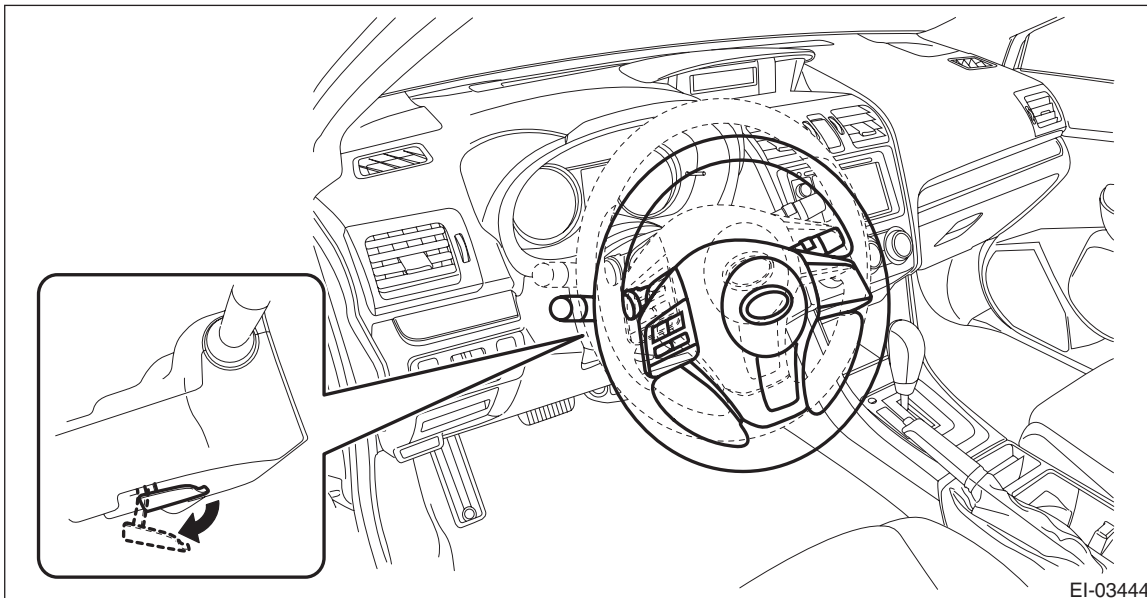

EI-03444

- 3) Release the screws, clips and claws, and remove the visor - combination meter.

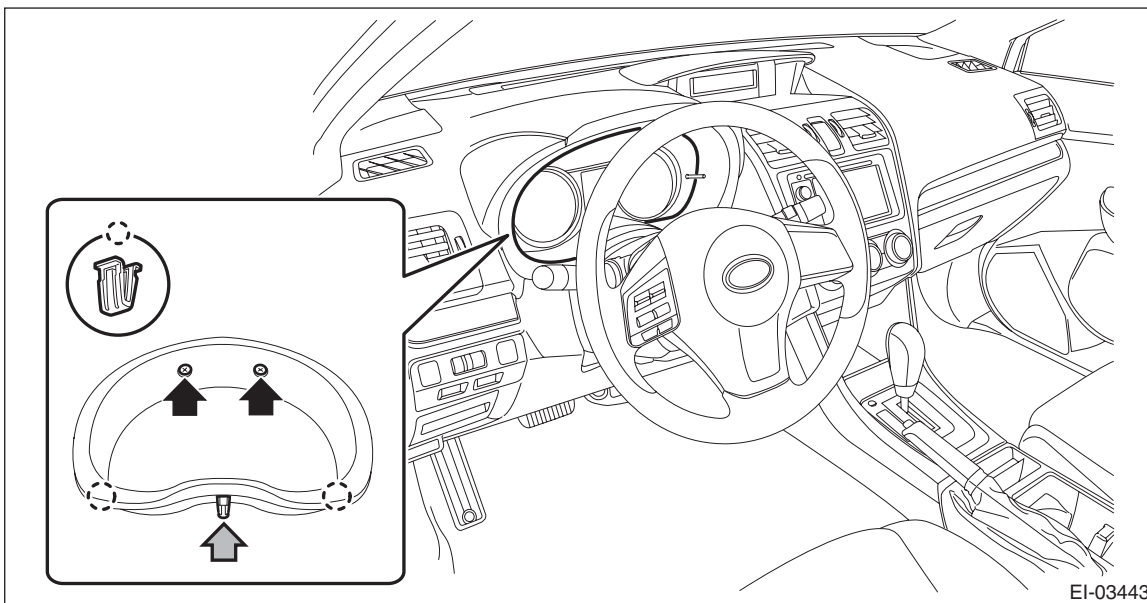

EI-03443

Combination Meter

INSTRUMENTATION/DRIVER INFO

4) Remove the combination meter assembly.

CAUTION:

- Be careful not to damage the meter or instrument panel.
- Pay particular attention to avoid damaging the meter glass.

(1) Remove the screws.

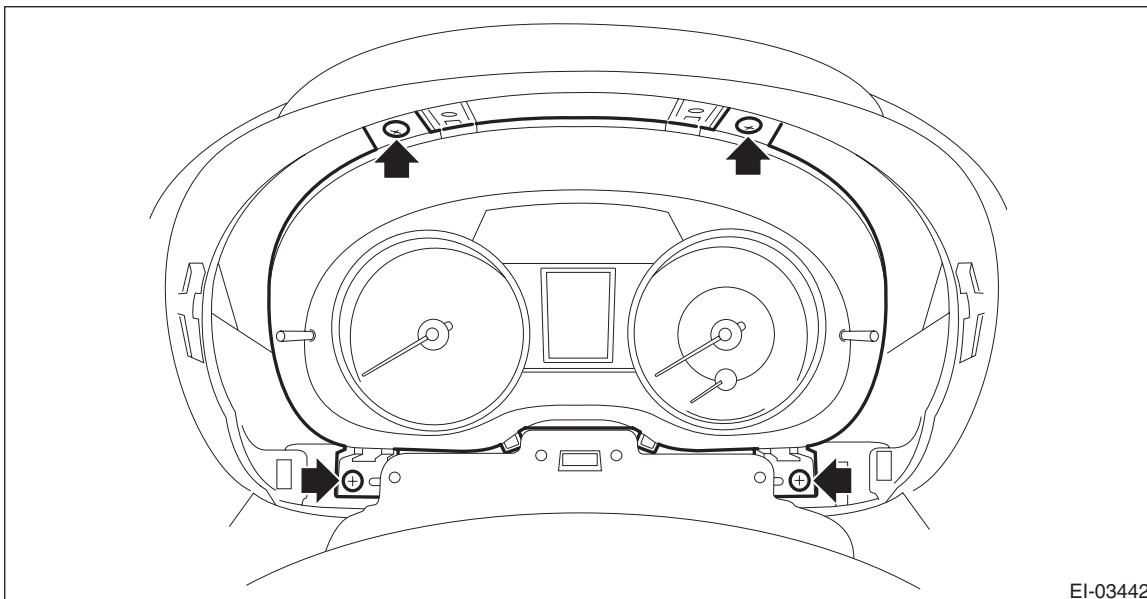

(2) Pull the combination meter assembly toward you and disconnect the connector.

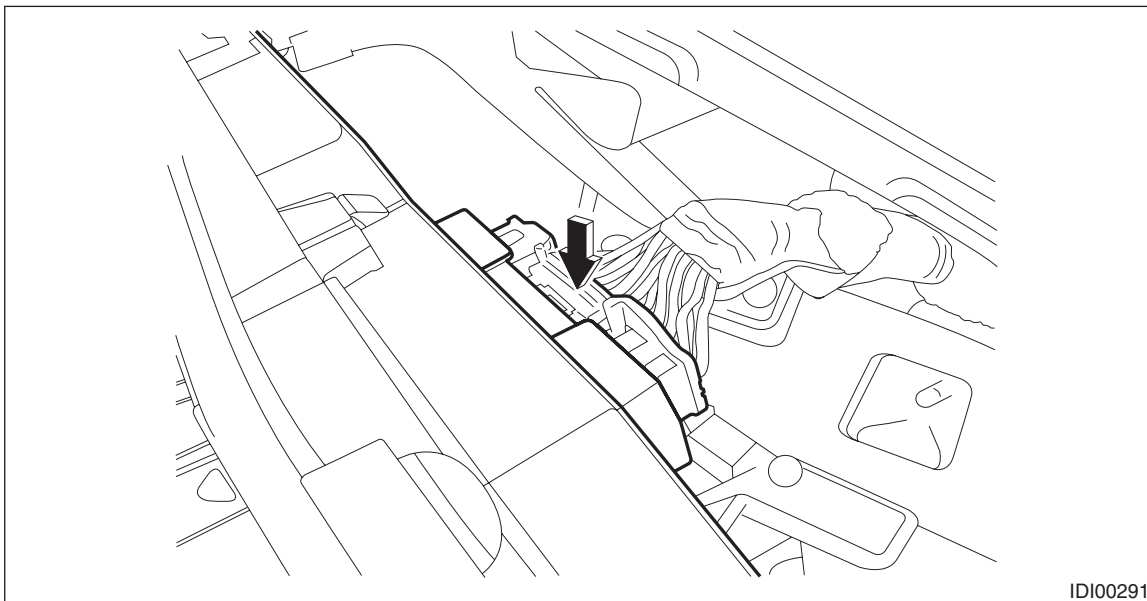

B: INSTALLATION

CAUTION:

- Make sure the electrical connector is connected securely.
- Make sure that each meter operates normally.
- When the combination meter assembly has been replaced, be sure to perform the registration of immobilizer.

Install each part in the reverse order of removal.

C: DISASSEMBLY

1. DISASSEMBLY OF COMBINATION METER ASSEMBLY

CAUTION:

- Use gloves to avoid damage and getting fingerprints on the glass surface and meter surfaces.
- Be careful not to apply excessive force to the trip knob.
- Be sure not to touch the meter indicator needle.

Release the claw, and remove the glass - combination meter (A) and visor - combination meter (B) from the meter - main assembly (C).

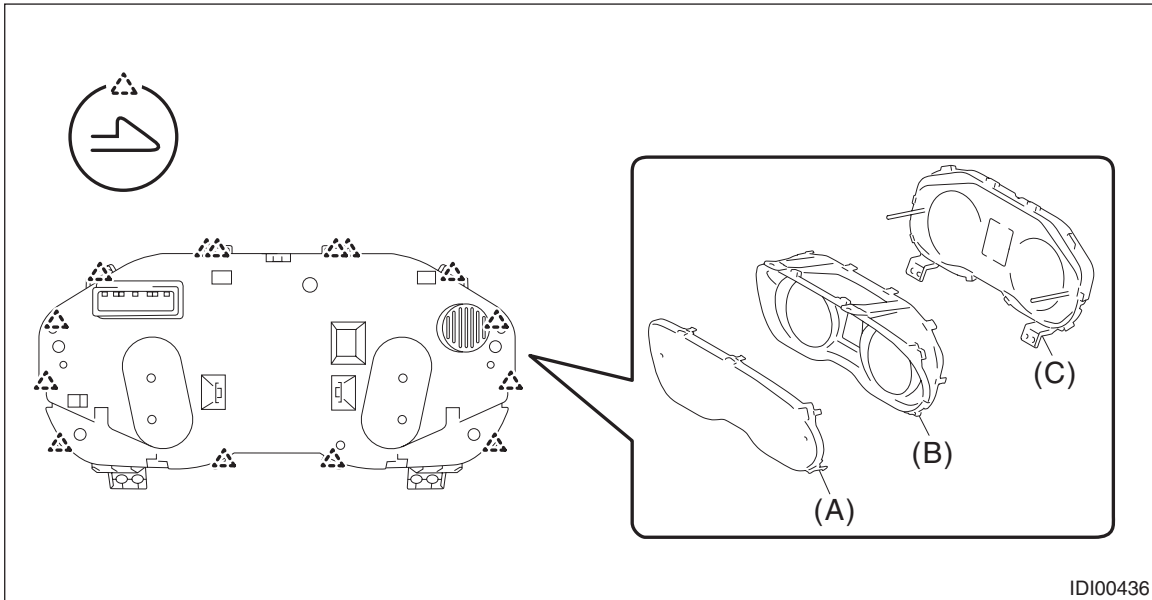

IDI00436

2. BULB REPLACEMENT

Because LEDs are used for all of warning lights and indicator lights of combination meters, replace the meter - main assembly if faulty.

D: ASSEMBLY

Assemble each part in the reverse order of disassembly.