

## 29. Fuel Sub Level Sensor

### A: REMOVAL

**WARNING:**

Place "NO OPEN FLAMES" signs near the working area.

**CAUTION:**

- Be careful not to spill fuel.
- If the fuel gauge indicates that two thirds or more of the fuel is remaining, be sure to drain fuel before starting work to avoid the fuel to spill.

1) Release the fuel pressure. <Ref. to FU(H4DO)-112, RELEASING OF FUEL PRESSURE, PROCEDURE, Fuel.>

2) Drain fuel. <Ref. to FU(H4DO)-113, DRAINING FUEL (WITH SUBARU SELECT MONITOR), PROCEDURE, Fuel.>

3) Disconnect the ground cable from battery.

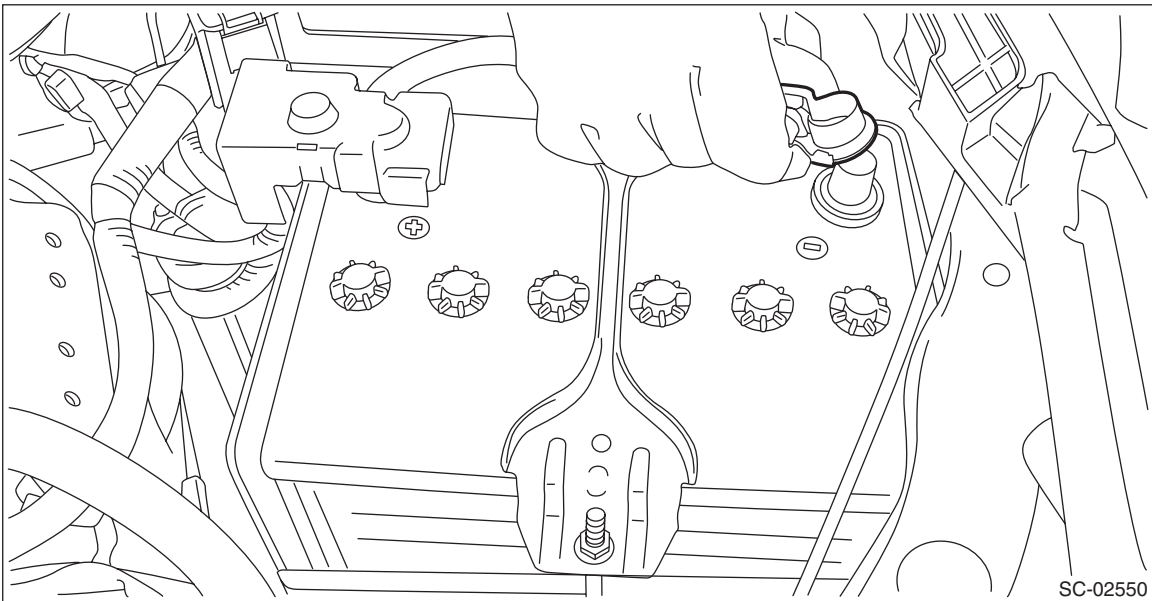

4) Remove the rear seat cushion. <Ref. to SE-22, REMOVAL, Rear Seat.>

5) Remove the service hole cover of fuel sub level sensor.

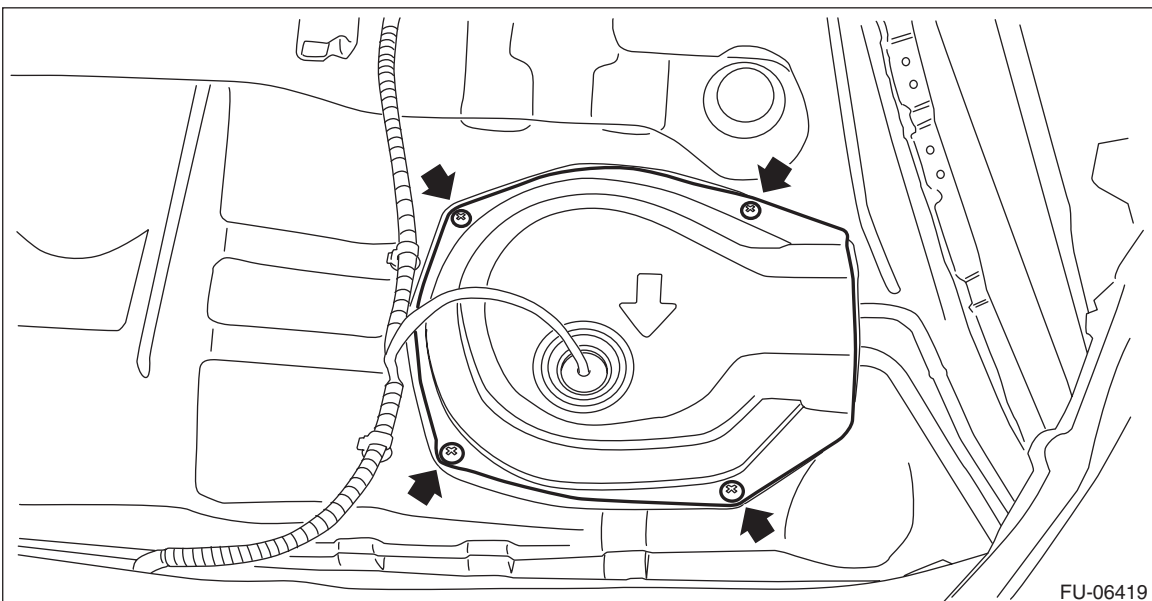

## Fuel Sub Level Sensor

### FUEL INJECTION (FUEL SYSTEMS)

---

- 6) Disconnect connectors from the fuel sub level sensor, and move aside the service hole cover.

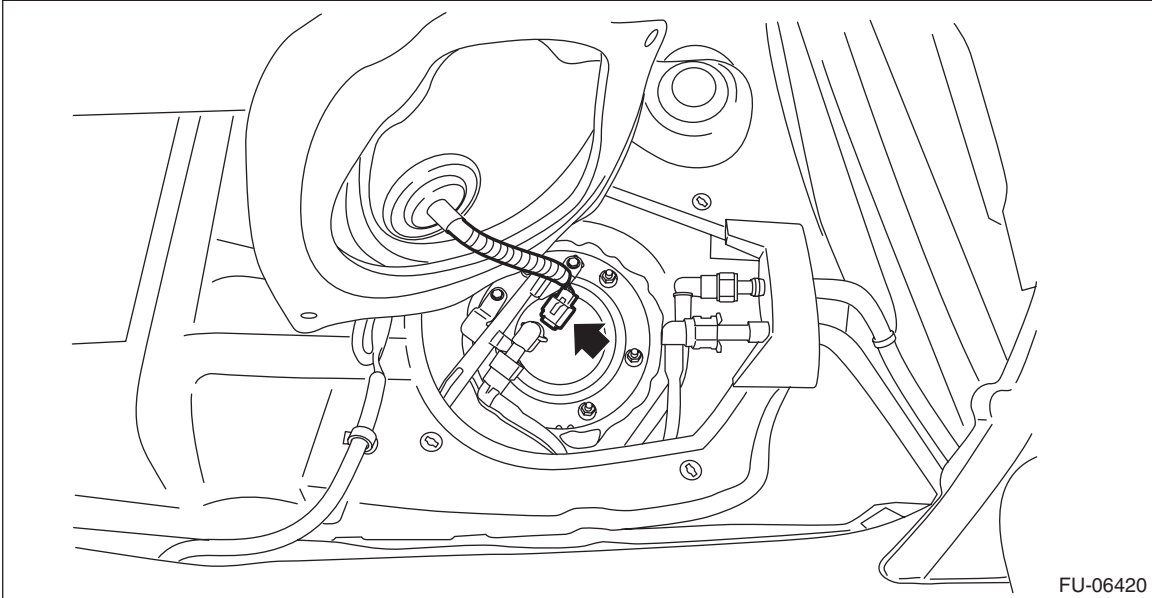

# Fuel Sub Level Sensor

7) Disconnect the quick connector of the jet pump tube.

**NOTE:**

Disconnect the quick connector as shown in the figure.

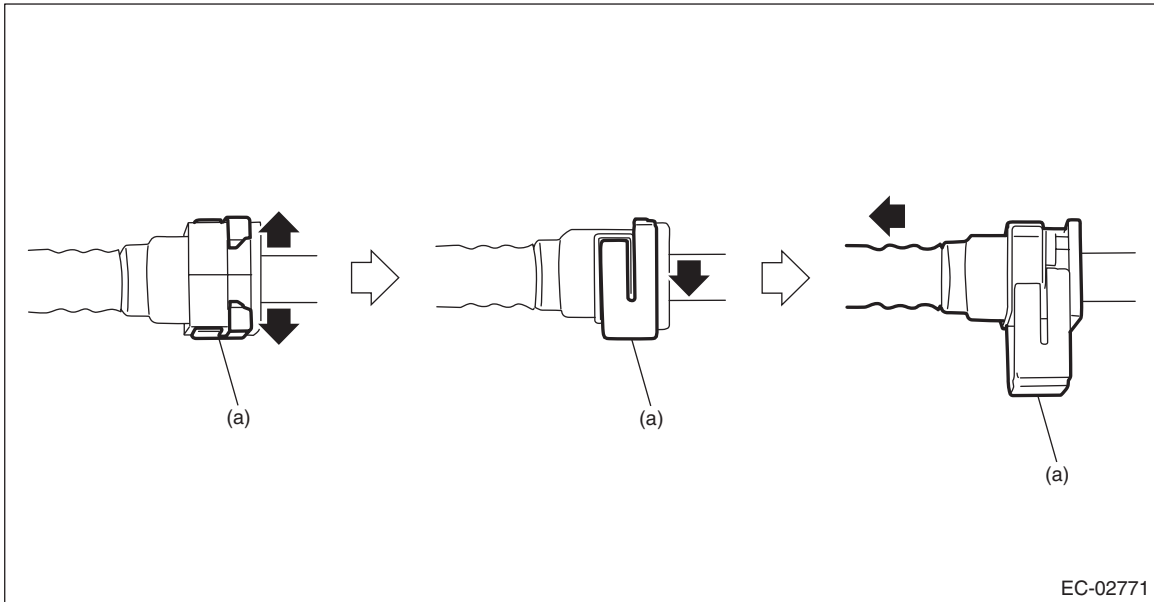

(a) Retainer

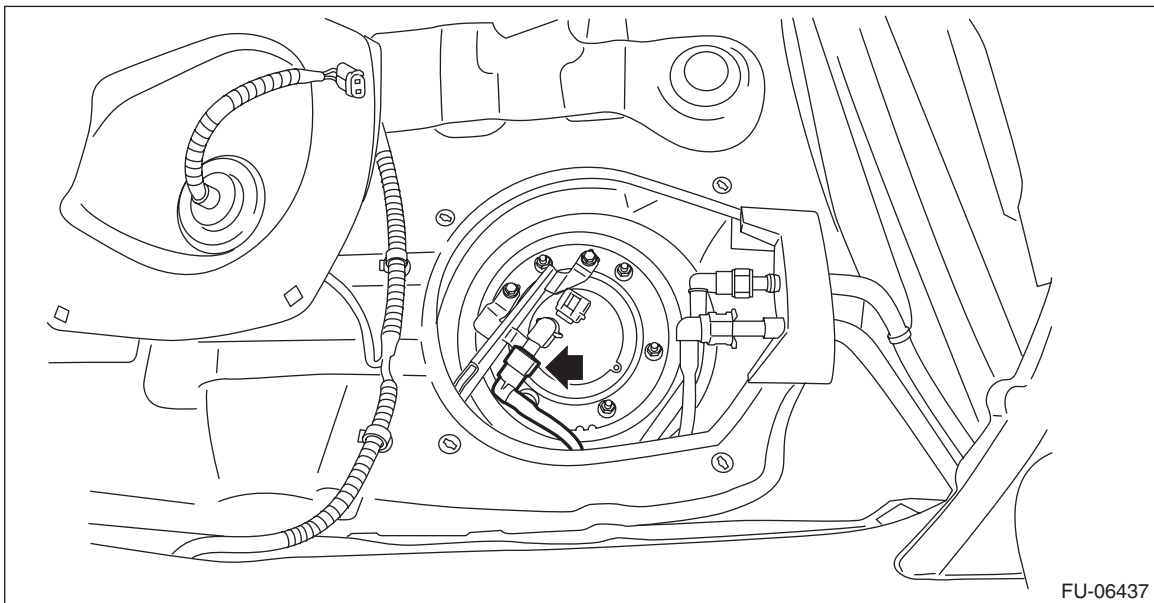

## Fuel Sub Level Sensor

### FUEL INJECTION (FUEL SYSTEMS)

8) Remove the fuel sub level sensor protector, and remove the rubber cap (A) from nut.

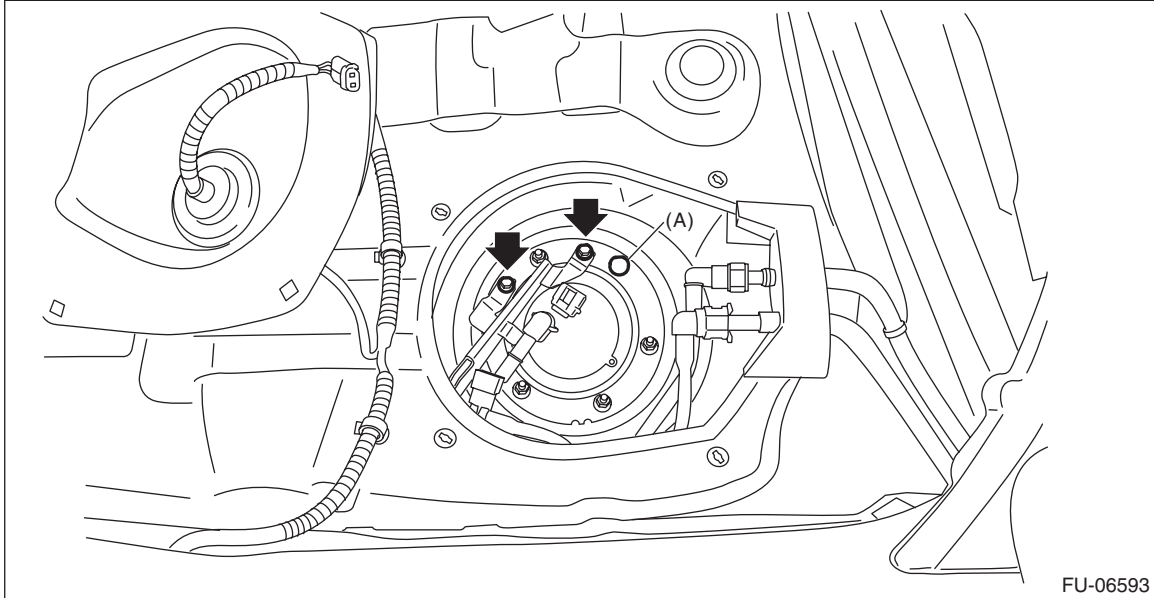

9) Remove the bolts and nuts which hold fuel sub level sensor protector and fuel sub level sensor upper plate to the fuel tank.

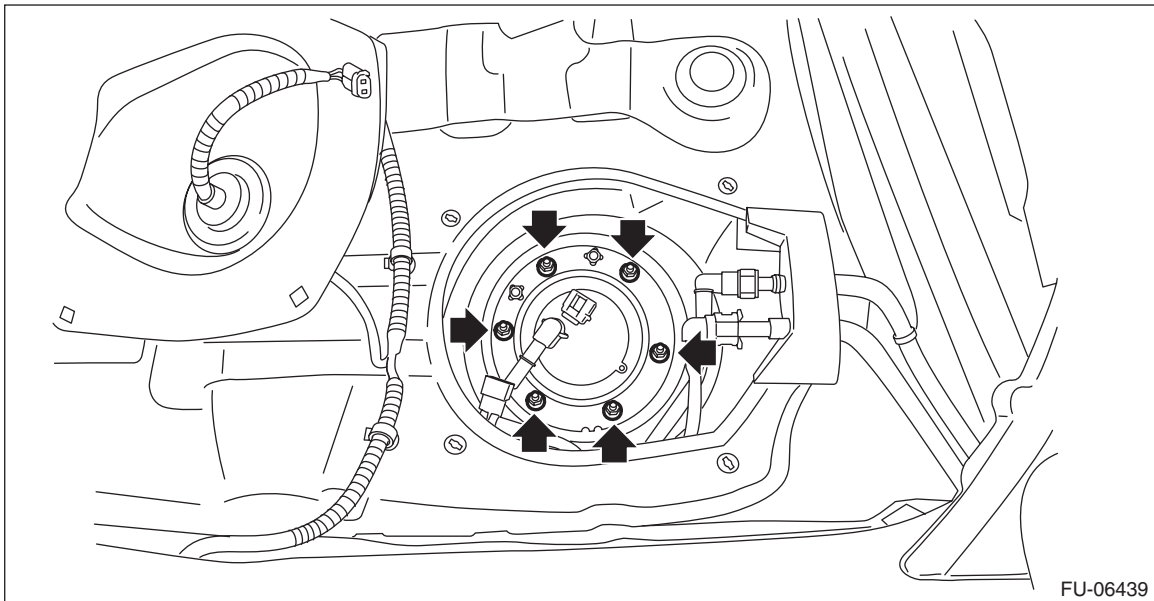

10) Remove the fuel sub level sensor from the fuel tank.

## B: INSTALLATION

Install in the reverse order of removal while being careful of the following.

- Make sure the sealing portion is free from fuel or foreign matter before installation.
- Align protrusion (A) of the gasket to the position shown in the figure.
- Align protrusion (B) of the fuel sub level sensor to the cutout in the fuel sub level sensor upper plate.
- Tighten the nuts and bolts to the specified torque in the order as shown in the figure.
- After tightening, install the rubber cap (C) at the position shown in the figure.

NOTE:

- Use a new gasket.
- Do not forget to install rubber cap (C).

**Tightening torque:**

**4.4 N·m (0.4 kgf-m, 3.2 ft-lb)**

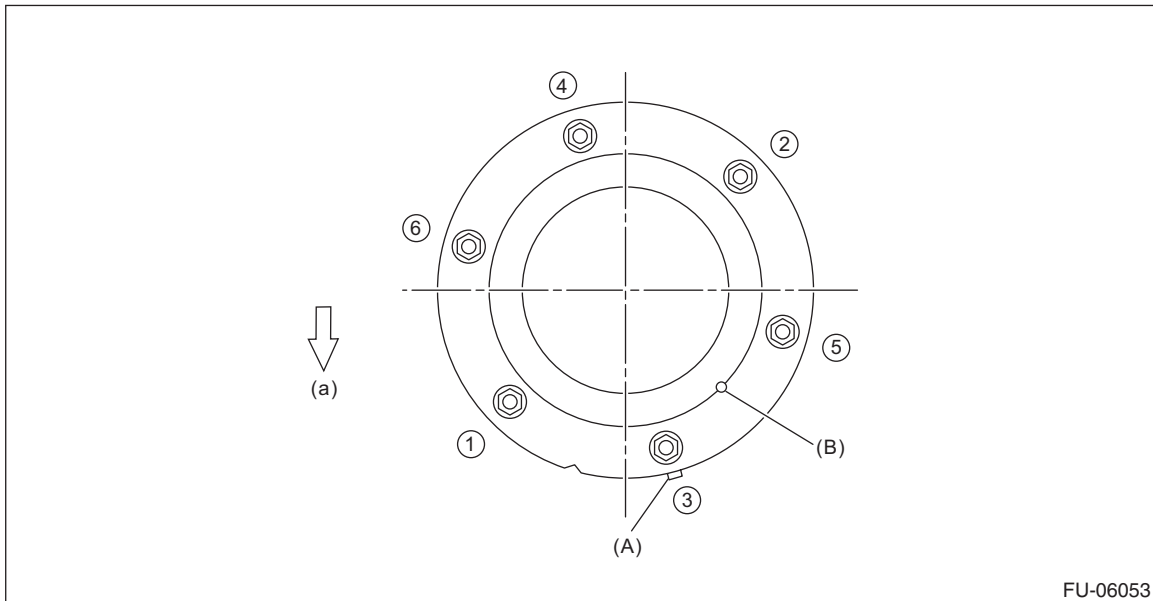

(a) Front side of vehicle

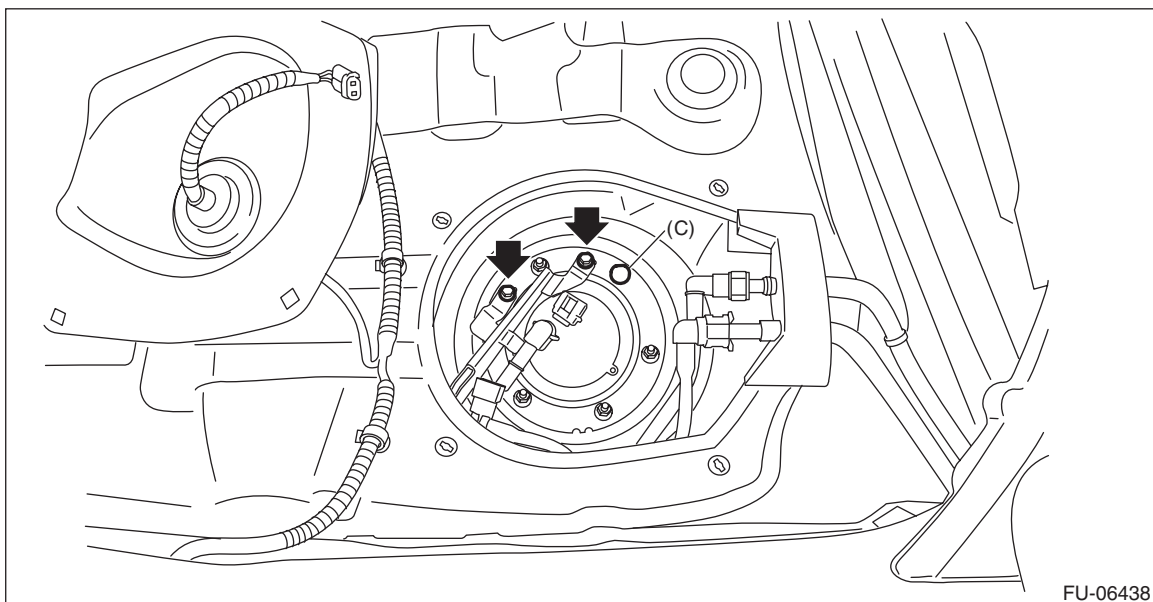

# Fuel Sub Level Sensor

## FUEL INJECTION (FUEL SYSTEMS)

### CAUTION:

- Check that there is no damage or dust on the quick connector. If necessary, clean the seal surface of the pipe.
- When connecting the quick connector, make sure to insert the pipe all the way in before locking the slider.
- When it is difficult to lock the slider, check that the pipe is fully inserted.
- Make sure that the quick connector is securely connected.

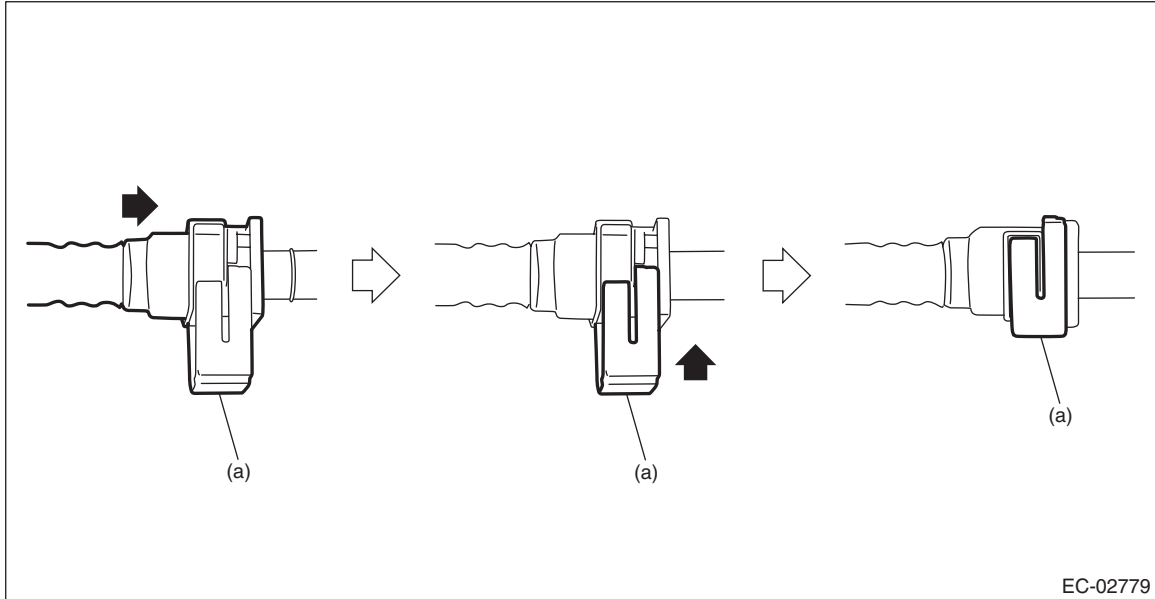

(a) Retainer

### C: INSPECTION

- 1) Check that the fuel sub level sensor has no damage.
- 2) Measure the fuel sub level sensor float position.

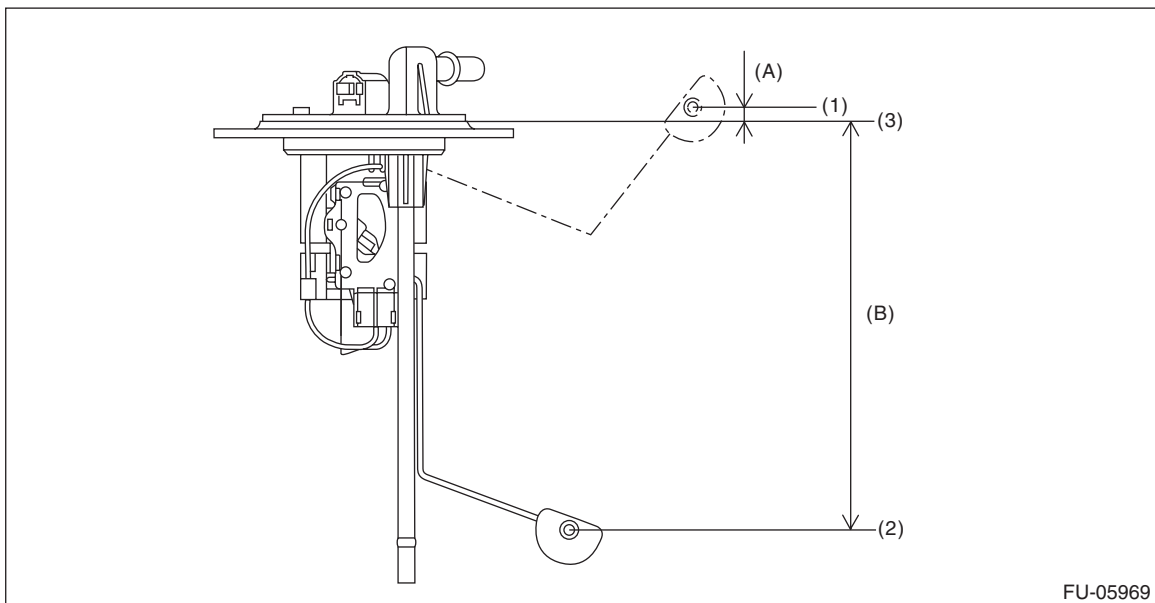

(1) FULL

(2) EMPTY

(3) Datum points

Float position	Standard
FULL to Datum point (A)	5.31±3.5 mm (0.209±0.138 in)
EMPTY to Datum point (B)	160.6±3.5 mm (6.32±0.138 in)

**FU(H4DO)-160**

# Fuel Sub Level Sensor

3) Measure the resistance between fuel sub level sensor terminals.

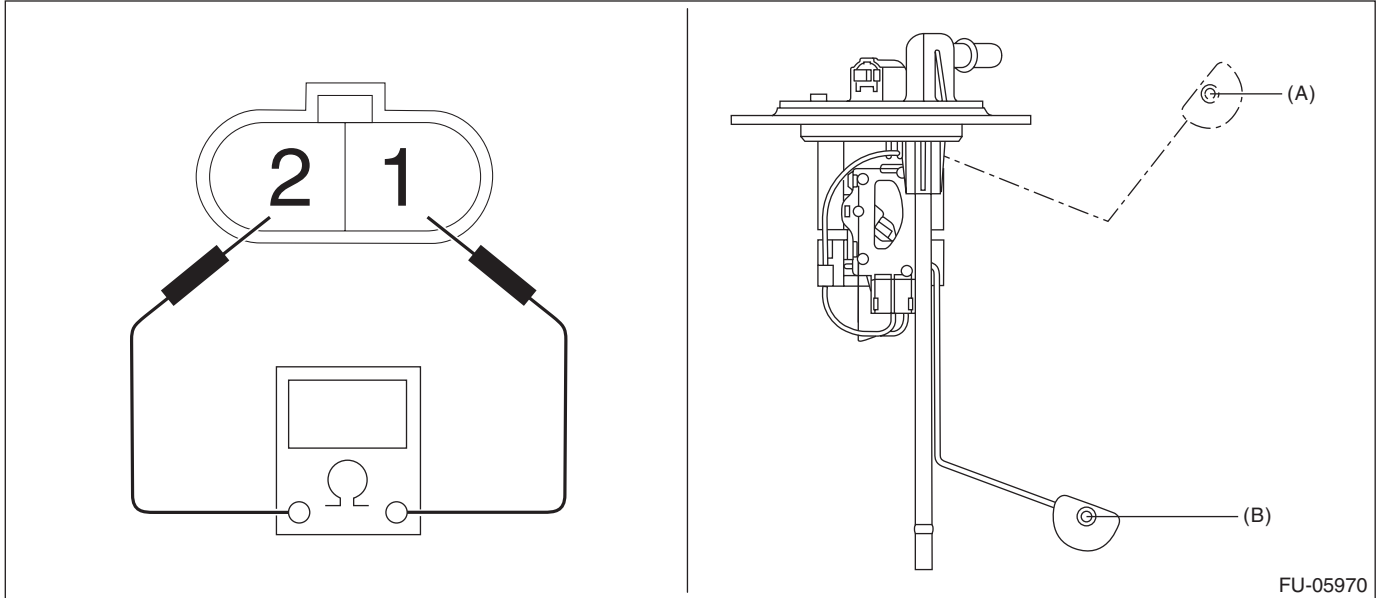

Float position	Terminal No.	Standard
FULL (A)	1 and 2	$8.7 \pm 1.0 \Omega$
EMPTY (B)		$270.9 \pm 4.0 \Omega$