

Rear Gate Opener Button

SECURITY AND LOCKS

12.Rear Gate Opener Button

A: REMOVAL

NOTE:

The button - opener rear gate is integrated with the rear lock button. (model with keyless access)

- 1) Remove the trim panel - rear gate. <Ref. to EI-147, REMOVAL, Rear Gate Trim.>
- 2) Remove the garnish assembly - rear gate. <Ref. to EI-152, REMOVAL, Rear Gate Garnish.>
- 3) Release the locks at both ends of the button - opener rear gate by pushing them with a flat tip screwdriver, and remove the button - opener rear gate.

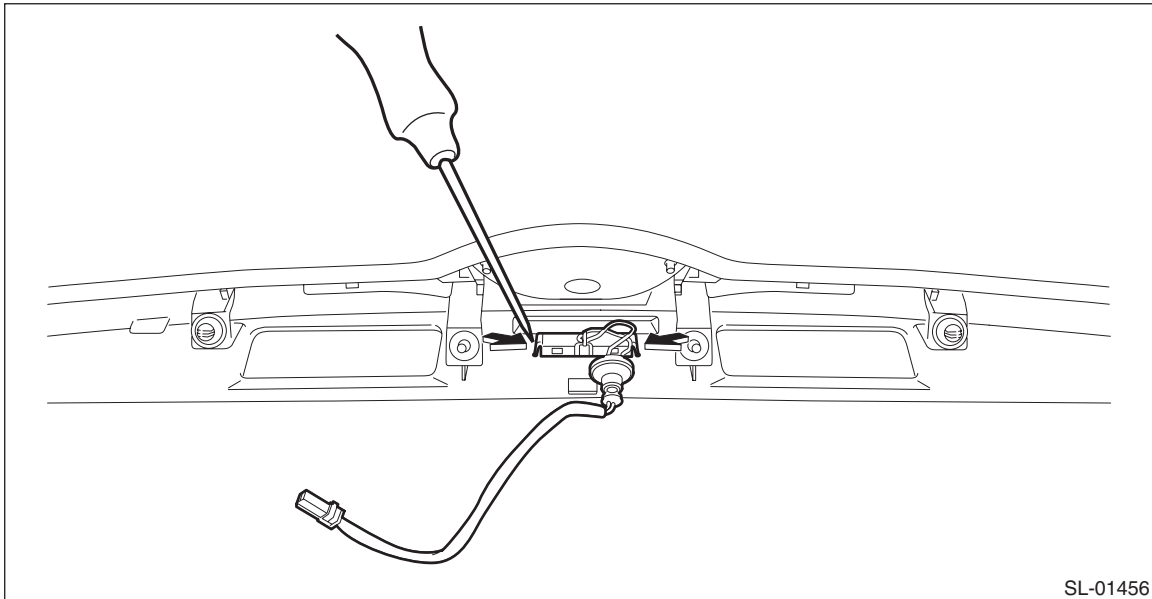

B: INSTALLATION

CAUTION:

Make sure that the harness grommet is securely installed.

If not properly installed, this may cause leaks.

Install each part in the reverse order of removal.

NOTE:

Refer to "INSTALLATION" of "Rear Gate Garnish". <Ref. to EI-154, INSTALLATION, Rear Gate Garnish.>

C: INSPECTION

UNIT INSPECTION

Preparation tool:

Circuit tester

1) Check the resistance between switch terminals.

Terminal No.	Inspection conditions	Standard	Connection diagram
1 — 2	OPEN	Less than 5 Ω	
	CLOSE	1 M Ω or more	

SL-01578

2) If the inspection result is not within the standard, replace the button - opener rear gate.