

Key Lock Cylinders

SECURITY AND LOCKS

18.Key Lock Cylinders

A: REPLACEMENT

1. STEERING LOCK

- 1) Disconnect the ground cable from battery.
- 2) Remove the cover assembly - column.
 - (1) Remove the screws by turning the steering wheel to right and left.

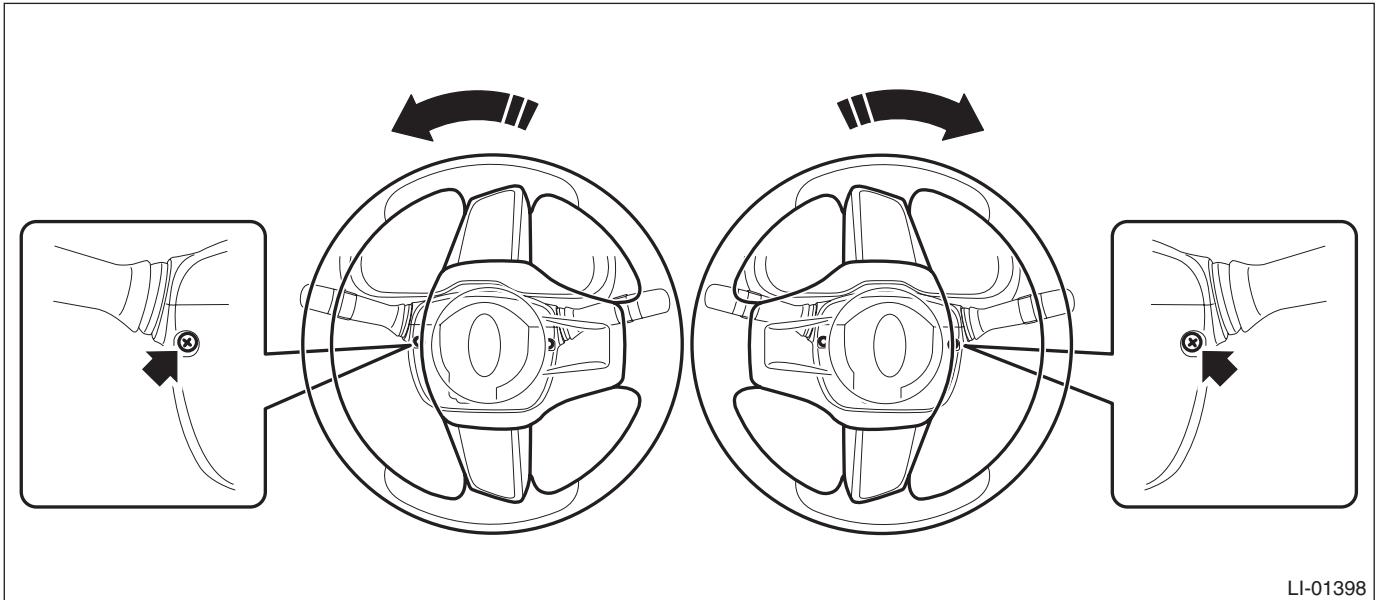

LI-01398

- (2) Release the claw, and remove the cover assembly - column UPR and the cover assembly - column LWR.

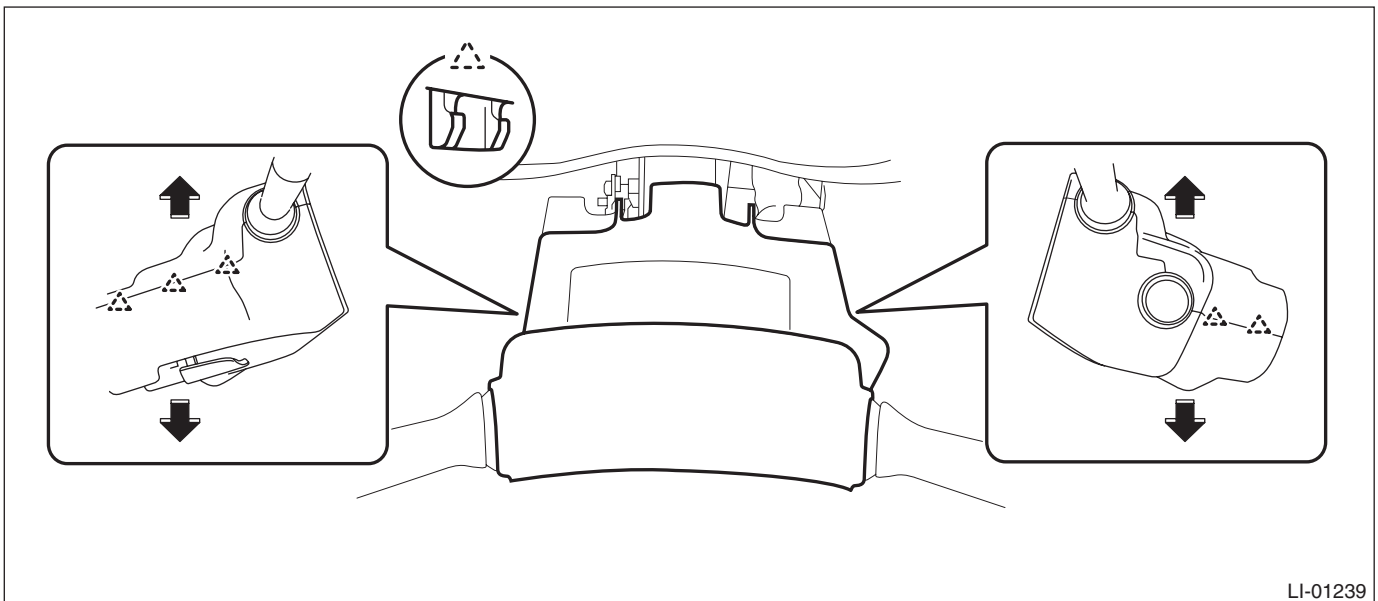

LI-01239

3) Disconnect the connector and remove the immobilizer antenna assembly.

CAUTION:

Do not apply excessive force to remove the immobilizer antenna and lock. Otherwise they may be broken because those parts are the products made of a plastic.

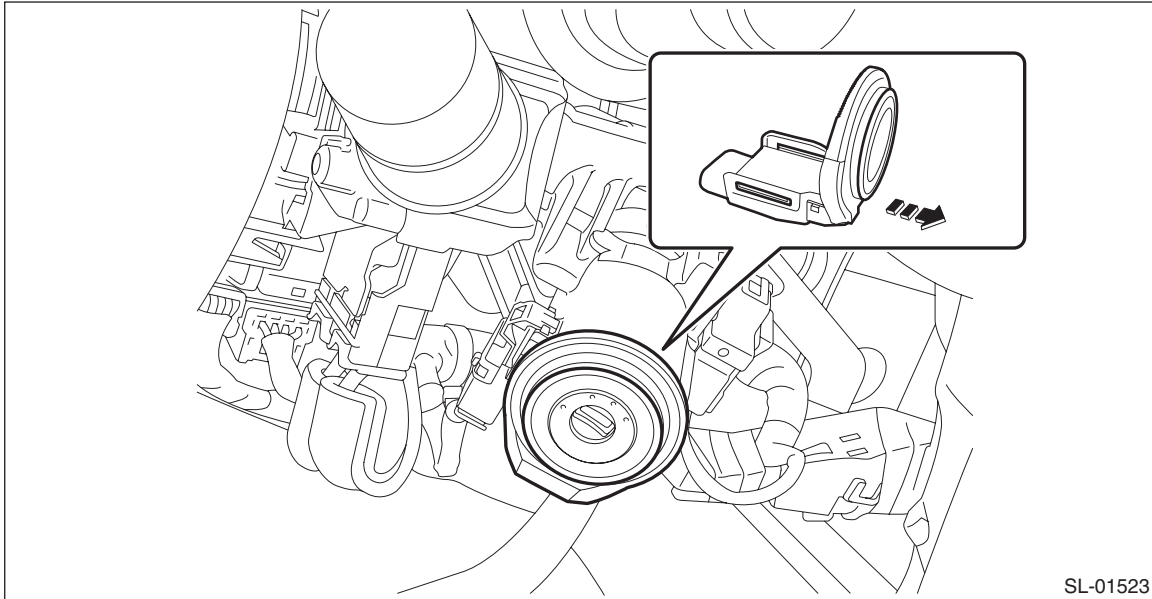

SL-01523

4) Remove the key lock solenoid.

(1) Disconnect the connector.

(2) Remove the screws and remove the key lock solenoid.

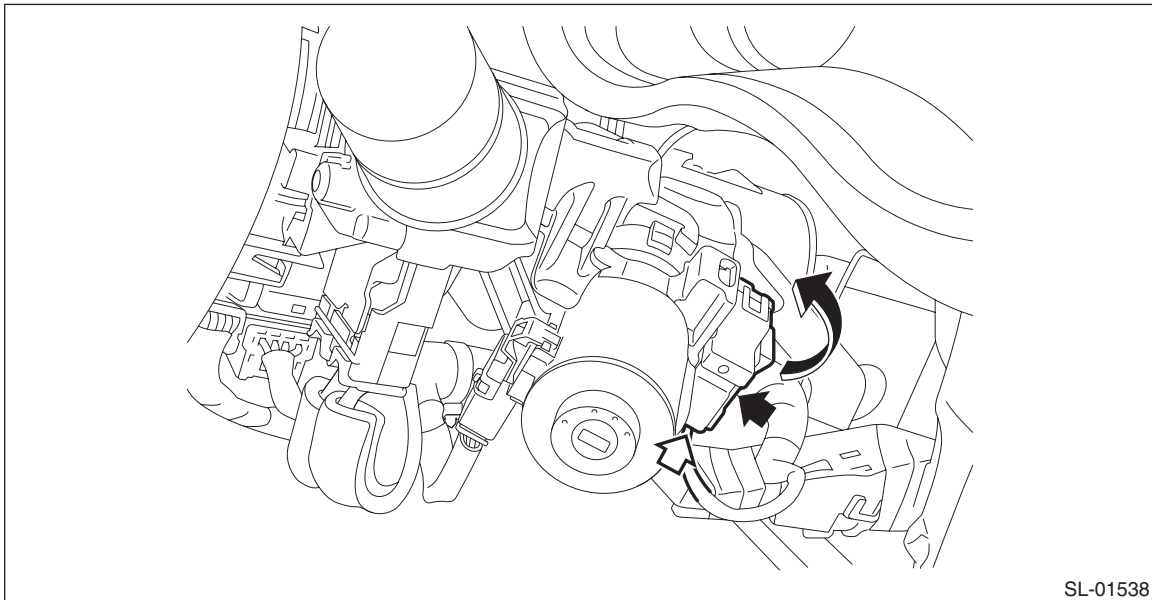

SL-01538

Key Lock Cylinders

SECURITY AND LOCKS

5) Replace the key cylinder.

(1) Insert the key into the key cylinder, and turn the key to the ACC position.

(2) Insert a flat tip screwdriver from the steering lock frame hole (A), and pull the key cylinder until the key cylinder claws touch the steering lock frame stopper (B).

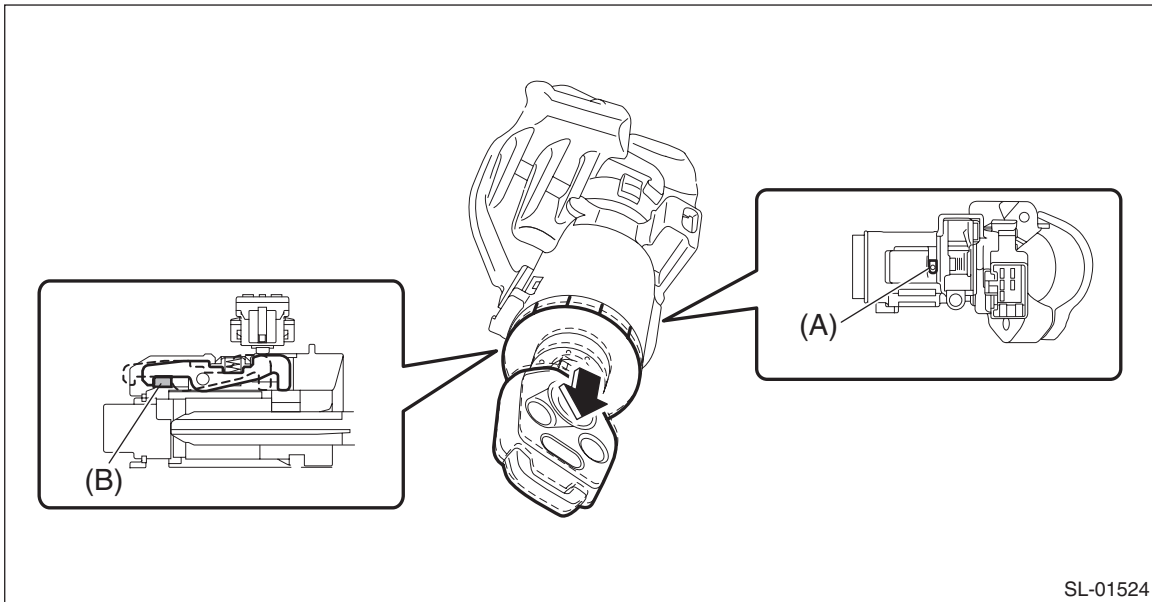

(3) Insert a flat tip screwdriver from the steering lock frame hole (A), and release the claws to pull out the key cylinder.

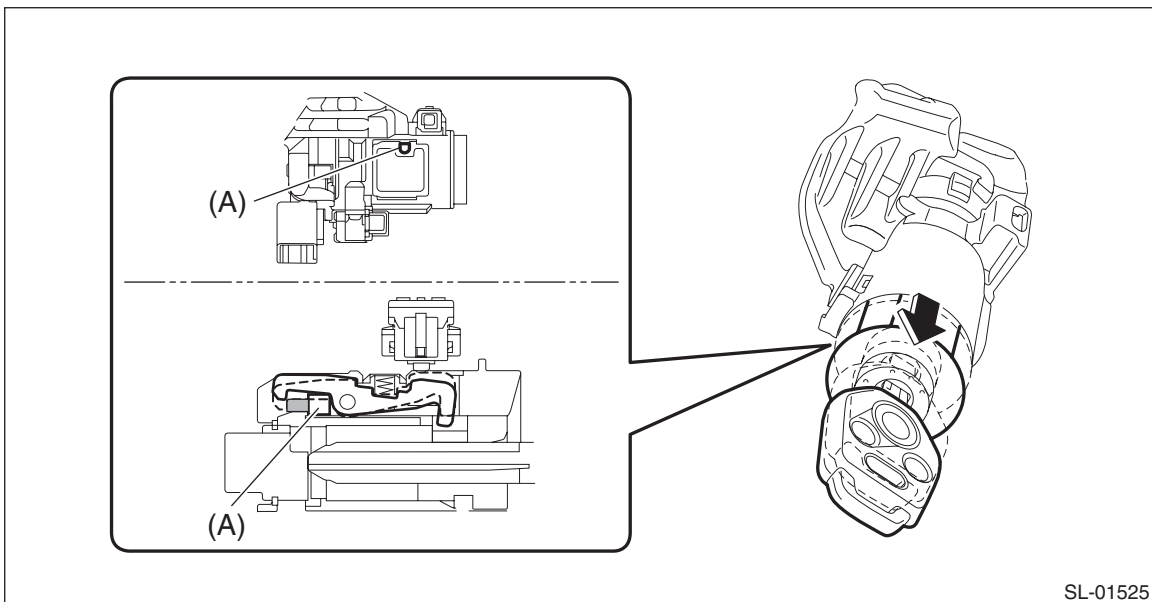

6) Install each part in the reverse order of removal.

2. FRONT DOOR

- 1) Raise the glass assembly - front door to the top position.
- 2) Remove the trim panel - front door. <Ref. to EI-61, FRONT DOOR, REMOVAL, Door Trim.>
- 3) Remove the sealing cover - front door.

CAUTION:

- Carefully remove the butyl tape. Excessive force will easily break the sealing cover - front door.
- If the sealing cover - front door gets broken, replace it with a new part.
 - (1) Remove the screw to remove the bracket - door trim front.
 - (2) Disconnect connectors.
 - (3) Carefully remove the butyl tape to remove the sealing cover - front door.

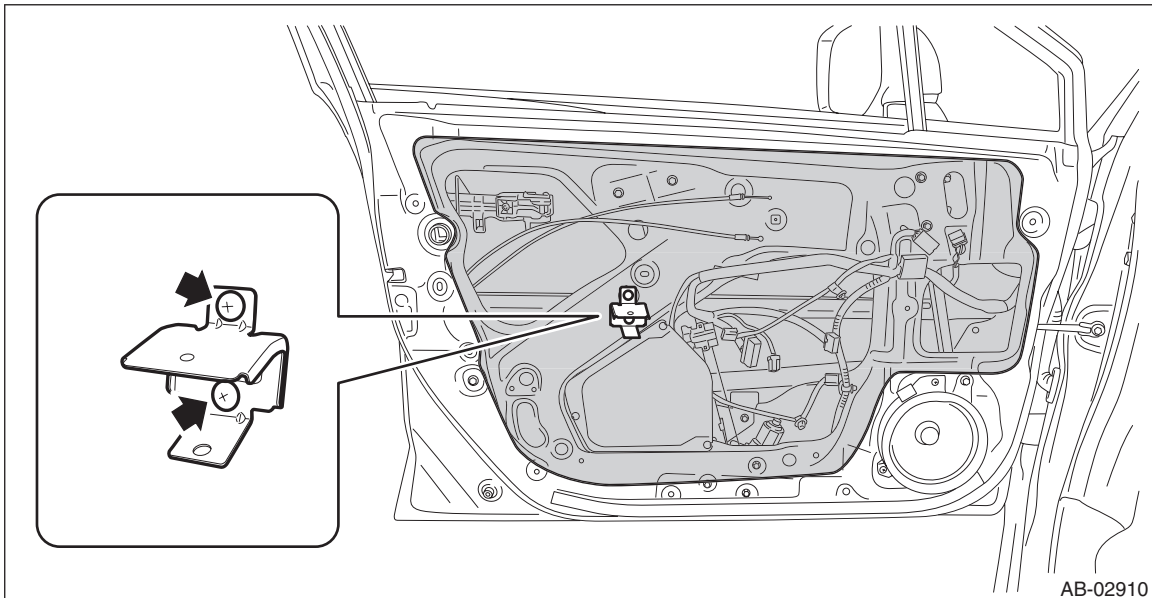

- 4) Remove the cover - handle front outer.

PREPARATION TOOL:

TORX® T30

- (1) Remove the plug at the rear end of the panel assembly - front door.
- (2) Loosen the TORX® bolt and remove the cover - handle front outer.

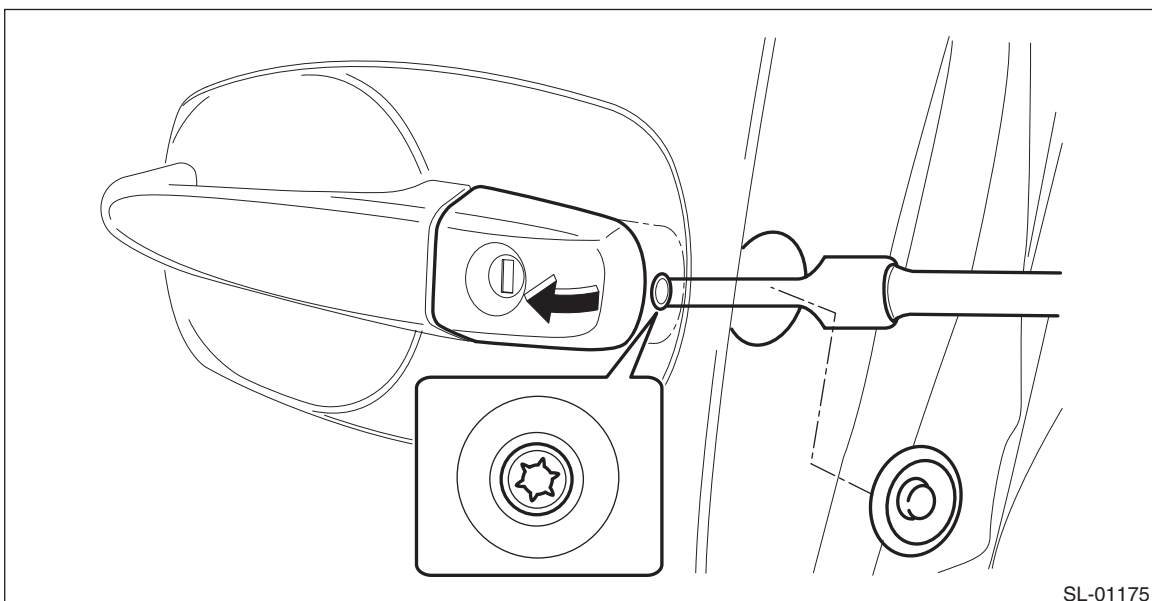

Key Lock Cylinders

SECURITY AND LOCKS

5) Remove the key cylinder (B) from the cover - handle front outer (A), and replace the key cylinder.

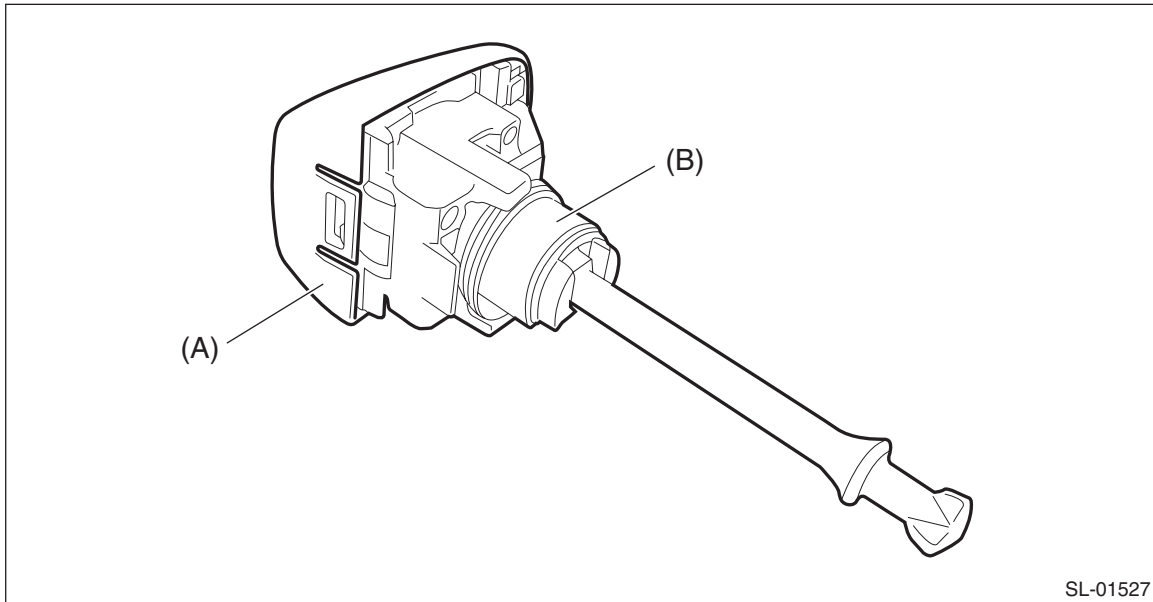

6) Install each part in the reverse order of removal.

Tightening torque:

Refer to "COMPONENT" of "General Description". <Ref. to SL-2, DOOR LOCK ASSEMBLY, COMPONENT, General Description.>

3. GLOVE BOX LID

1) Remove the pocket assembly.

(1) Attach the protective tape (a) to the panel center LWR.

(2) Remove the damper COMPL - pocket.

(3) Release the stoppers and remove the pocket assembly by pulling it toward you.

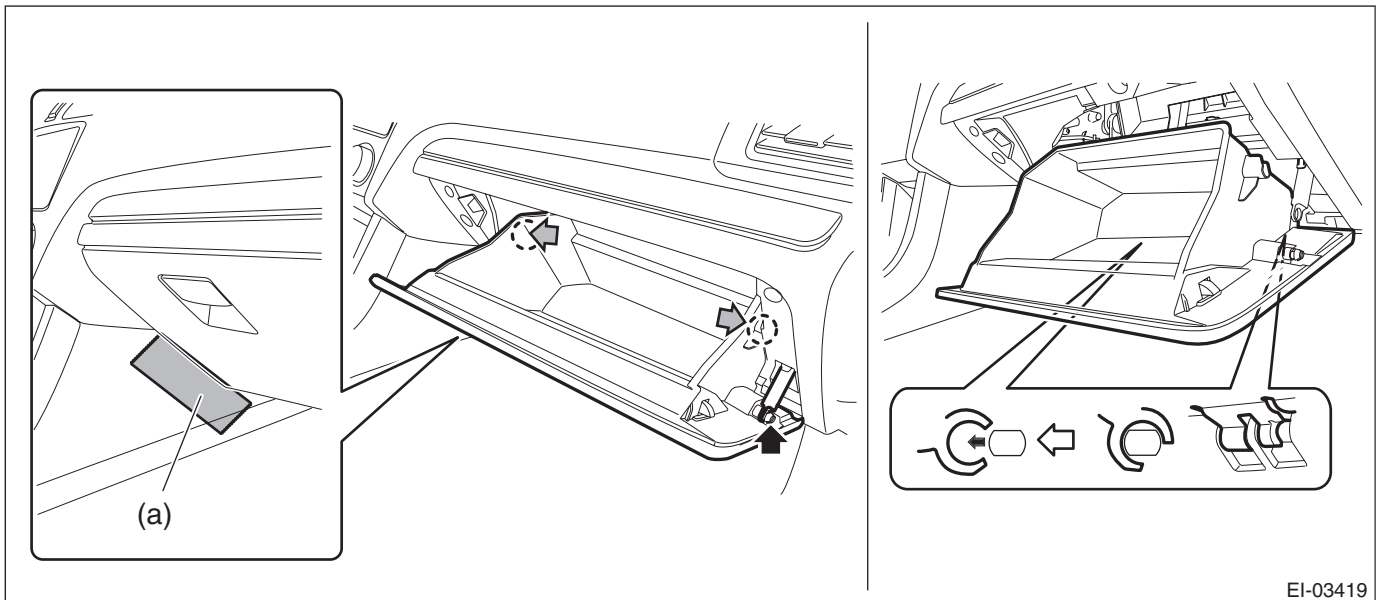

- 2) Replace the key cylinder.
 - (1) Pull up the lock knob.
 - (2) Push out the key cylinder from the pocket assembly while pressing in the metal plate.

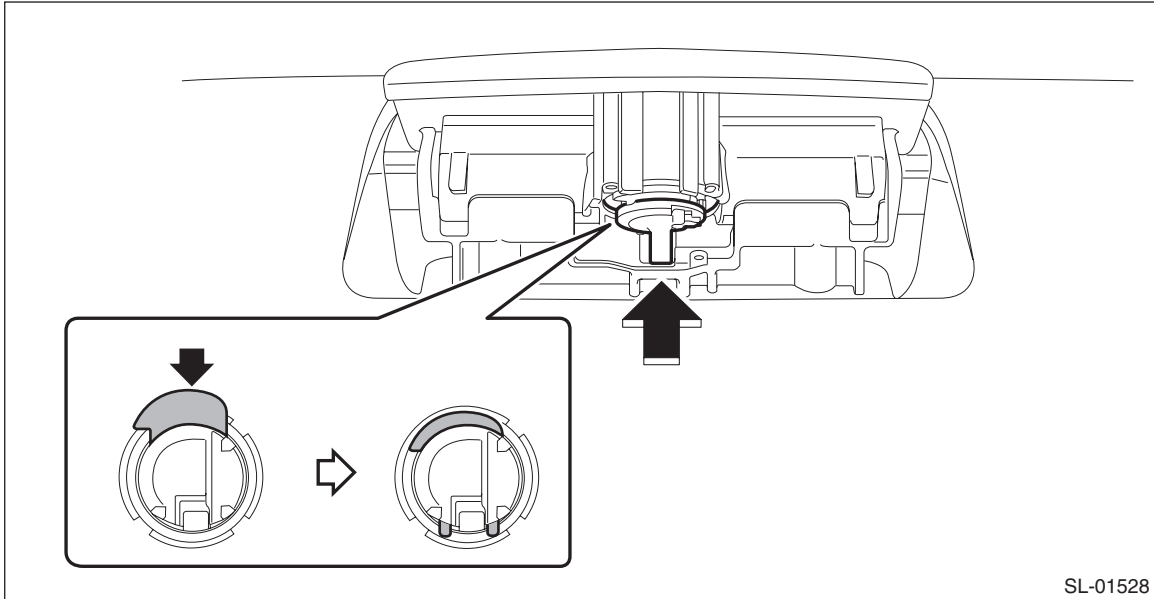

SL-01528

- 3) Install each part in the reverse order of removal.