

11. Roof Molding

A: REMOVAL

CAUTION:

Be careful not to damage the body.

- 1) Remove the roof rail assembly. (model with roof rail) <Ref. to EI-60, REMOVAL, Roof Rail.>
- 2) Turn over the front end of the molding - roof.
- 3) Slide the inner fastener in the direction of the arrow using a flat tip screwdriver, then remove the fastener from the stud on the vehicle side.

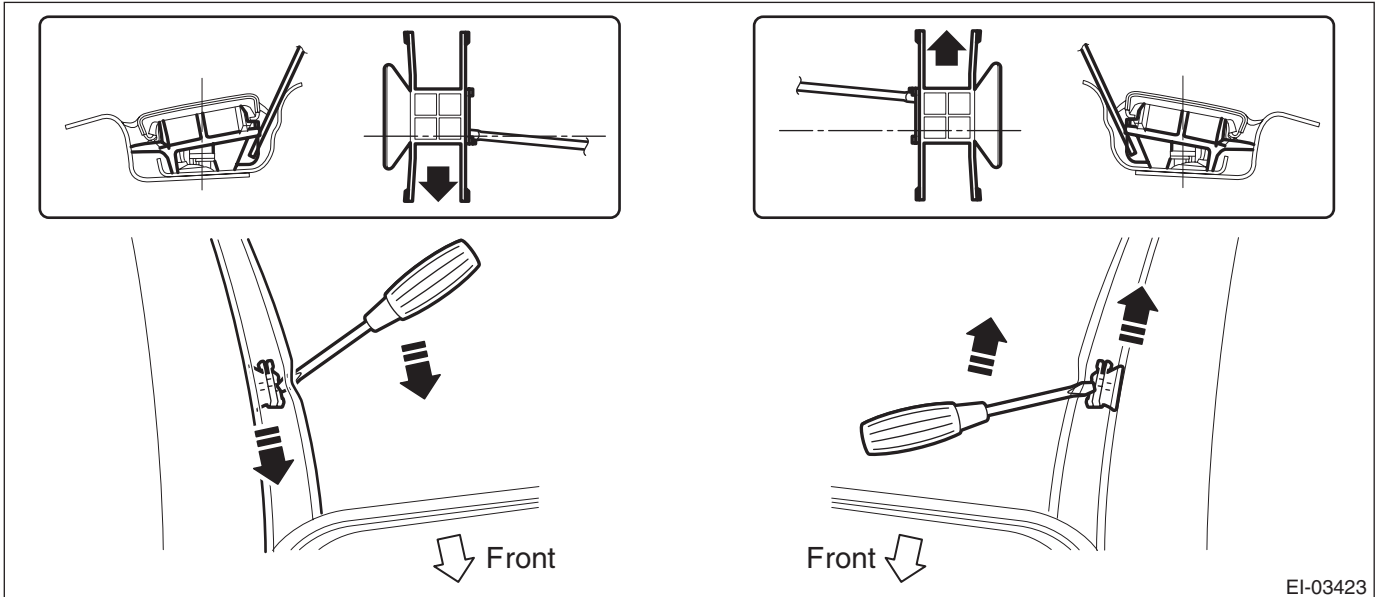

Right side: Slide towards the front of the vehicle.

Left side: Slide towards the rear of the vehicle.

- 4 door model: 6 locations per side

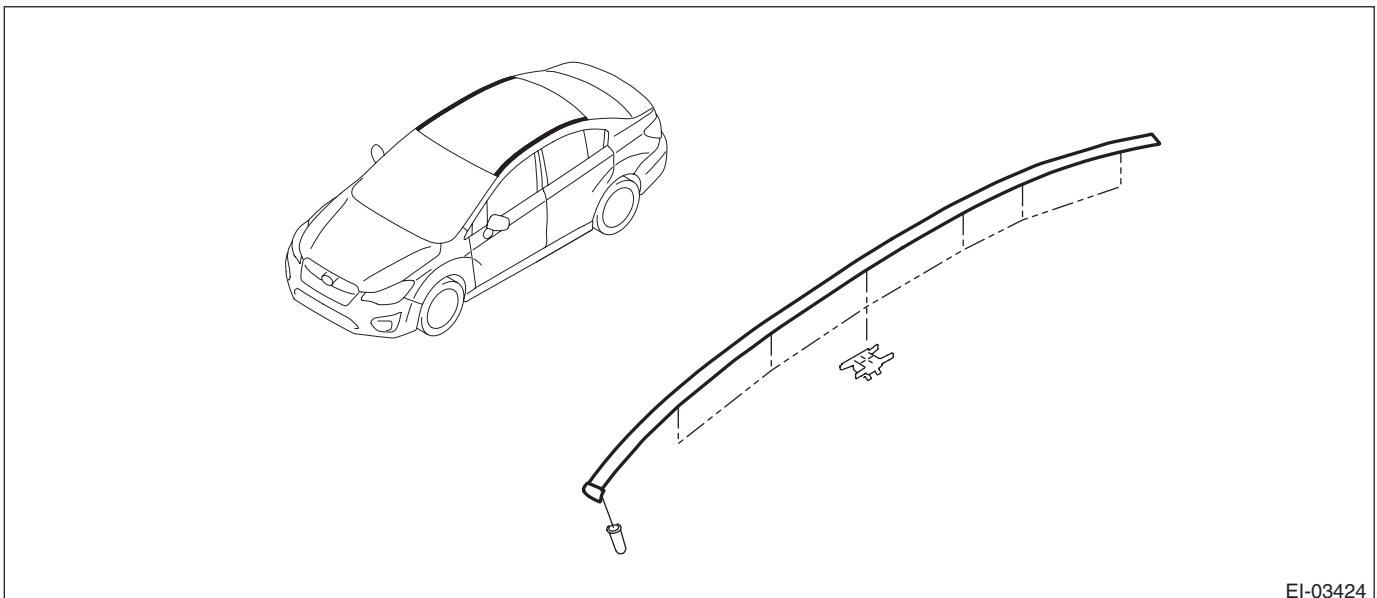

Roof Molding

EXTERIOR/INTERIOR TRIM

- 5 door model/XV model
 - Model without roof rail: 8 locations per side
 - Model with roof rail: 5 locations per side

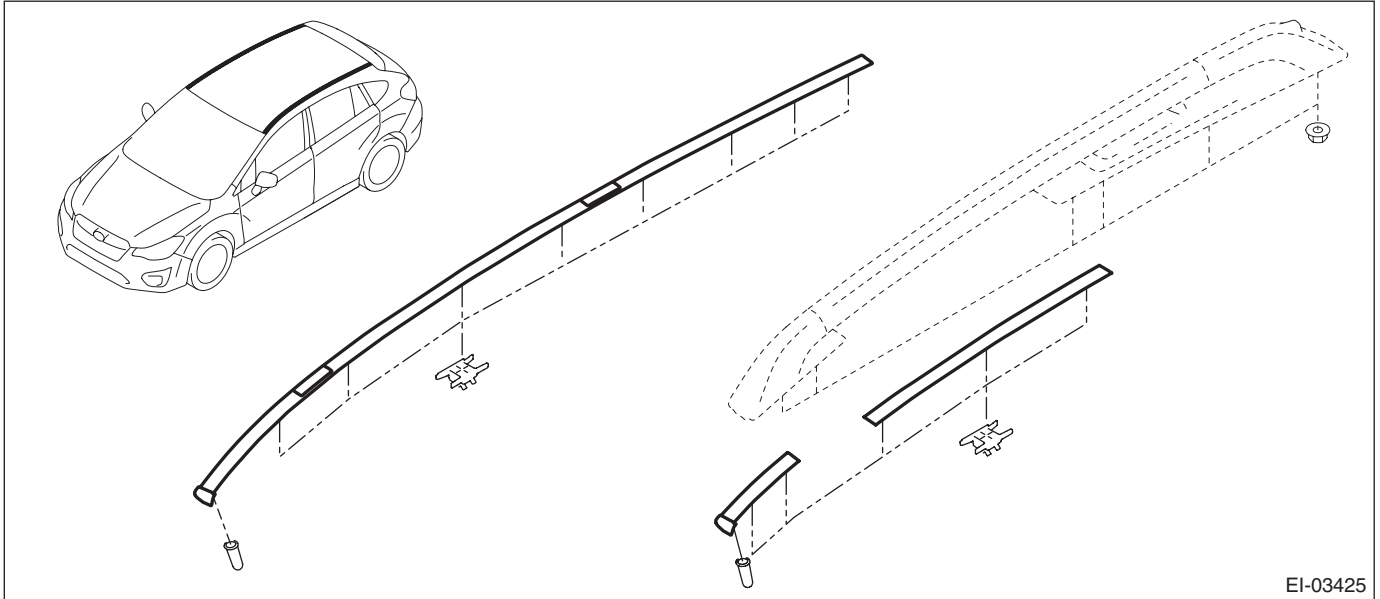

EI-03425

4) Pull up the molding - roof, and remove from the vehicle.

B: INSTALLATION

1) Remove the clips from the molding - roof, and attach to the studs on the vehicle.

CAUTION:

- Always replace the clips that were damaged during removal of the molding - roof with new parts.
- While installing the molding - roof, be careful not to catch the glass molding with the tip of the front side and rear side.

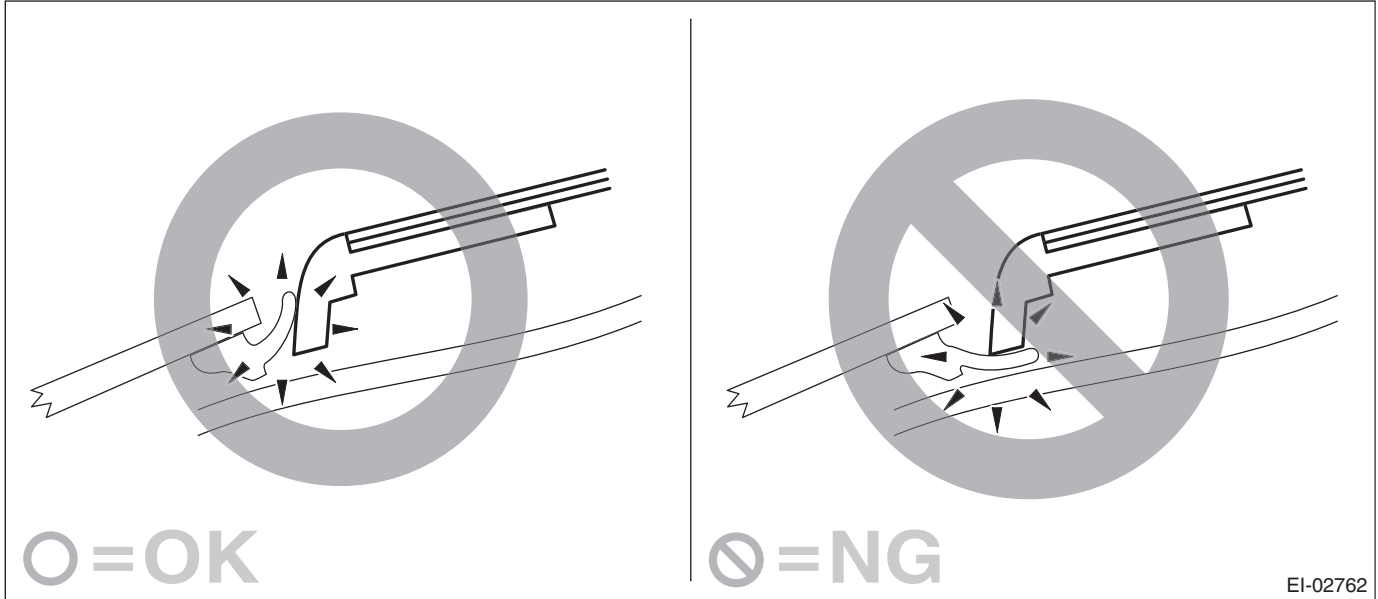

2) Push the front end of the molding - roof against the front window, and attach the forward positioning clip onto the rivet on the body.

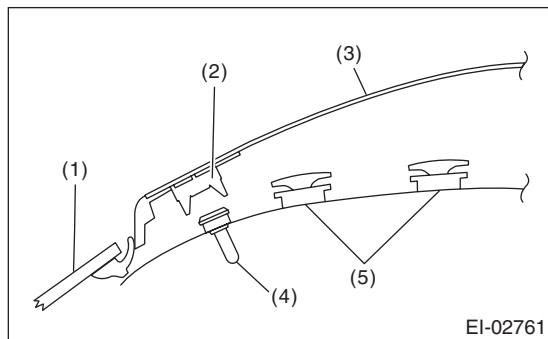

- (1) Windshield
- (2) Positioning clip
- (3) Molding - roof
- (4) Rivet
- (5) Clip

3) While pushing down the molding - roof from above, connect the molding - roof and the clip.