

Instrument Panel Assembly

EXTERIOR/INTERIOR TRIM

18. Instrument Panel Assembly

A: REMOVAL

CAUTION:

Be careful not to damage the airbag system harness when servicing the instrument panel. Damage may cause the system to malfunction.

NOTE:

Remove the instrument panel assembly and the beam COMPL - steering as a unit.

1) Disconnect the ground cable from battery.

NOTE:

On CVT models, shift the select lever into "D" before disconnecting the battery ground cable.

2) Remove the console box assembly.

(1) Release the claws, and then remove the boot - hand brake.

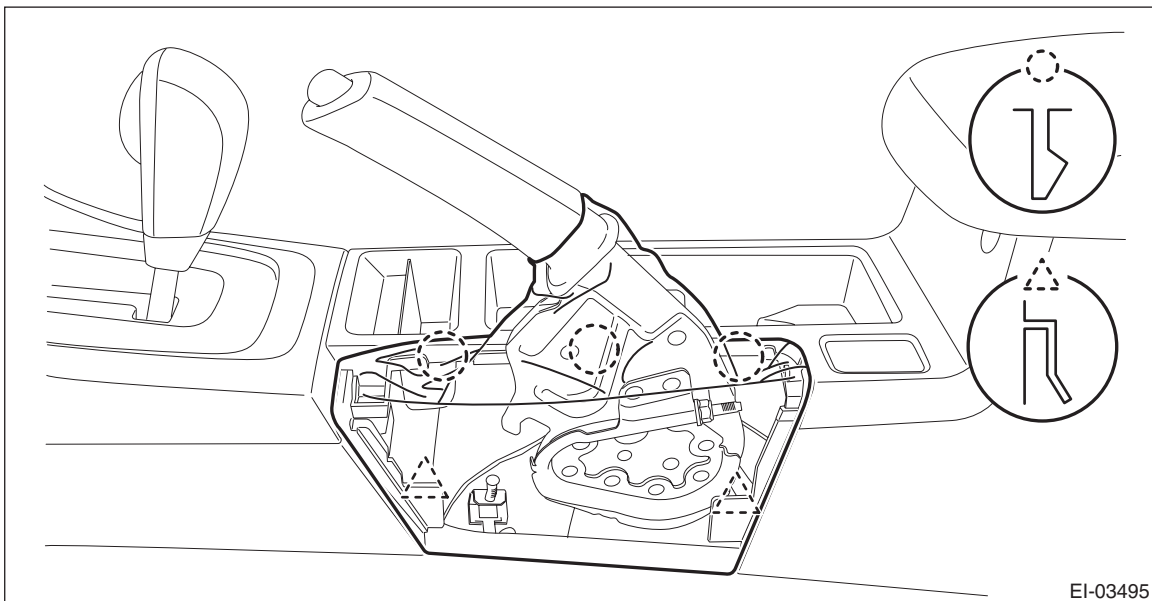

(2) Move the seat forward, and remove the bolts after detaching the left and right caps.

(3) Remove the screws, disconnect the harness connector and remove the console box assembly.

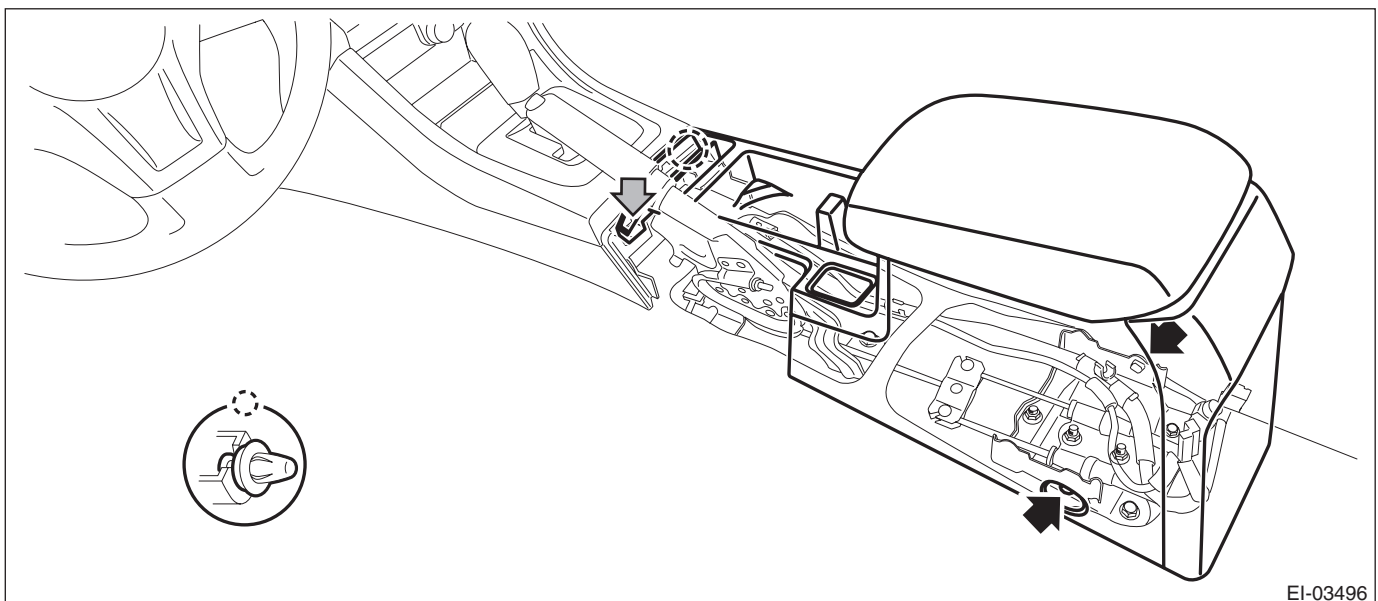

3) Remove the cover - shift lever.

- (1) Remove the shift knob. (MT model)
- (2) Release the clips and claws, then pull up the cover - shift lever.

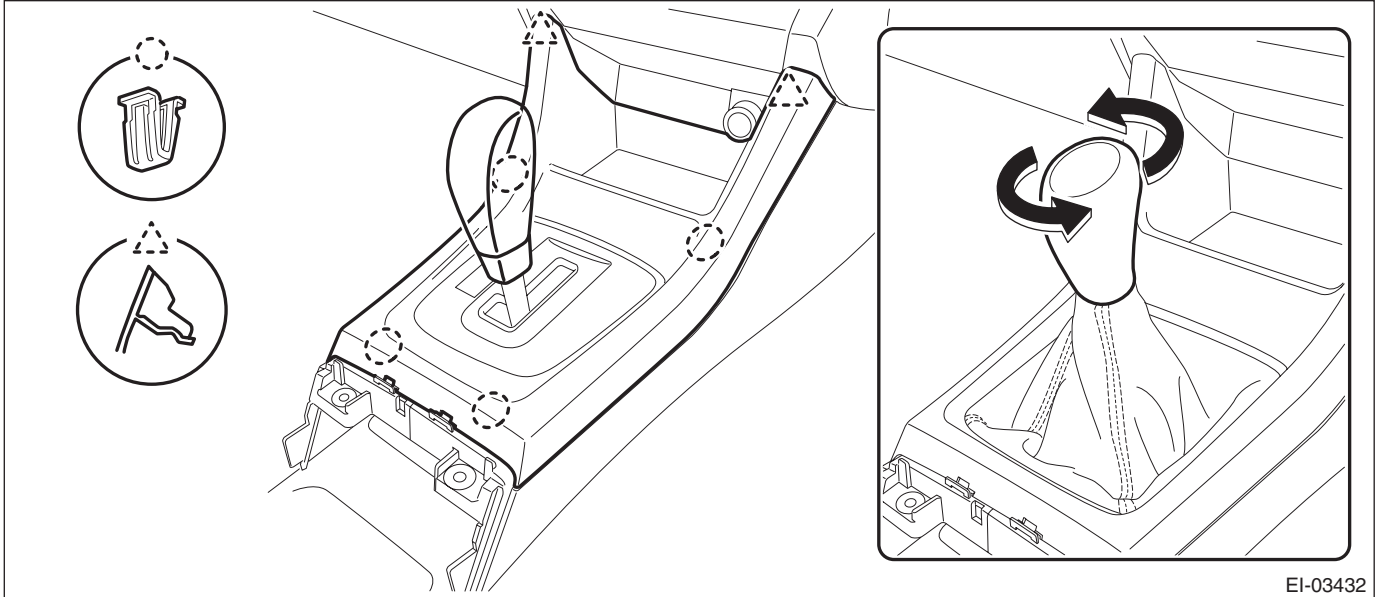

4) Remove the left and right panel center LWR.

- (1) Remove the screws and clips.
- (2) Release the claws, and then pull the panel center LWR to remove.

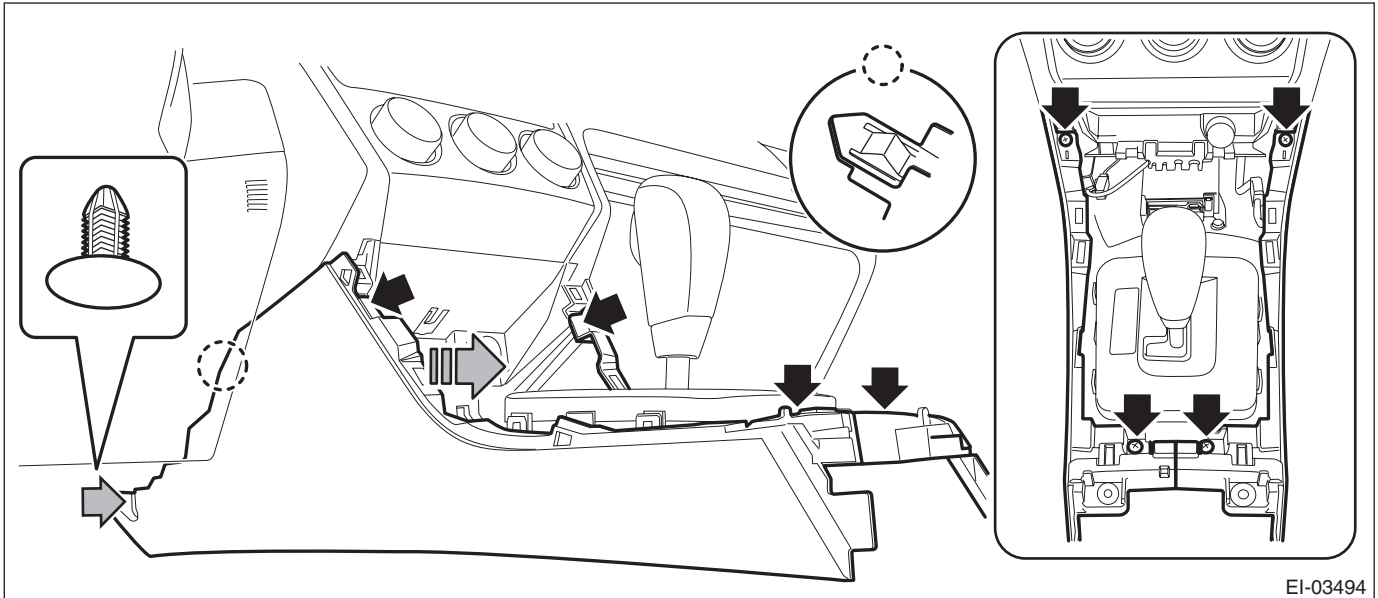

Instrument Panel Assembly

EXTERIOR/INTERIOR TRIM

5) Remove the cover assembly - instrument panel LWR driver.

CAUTION:

When removing the cover assembly - instrument panel LWR driver, be sure to pull it toward you. If attempting to remove by turning it upward, the claws may be damaged.

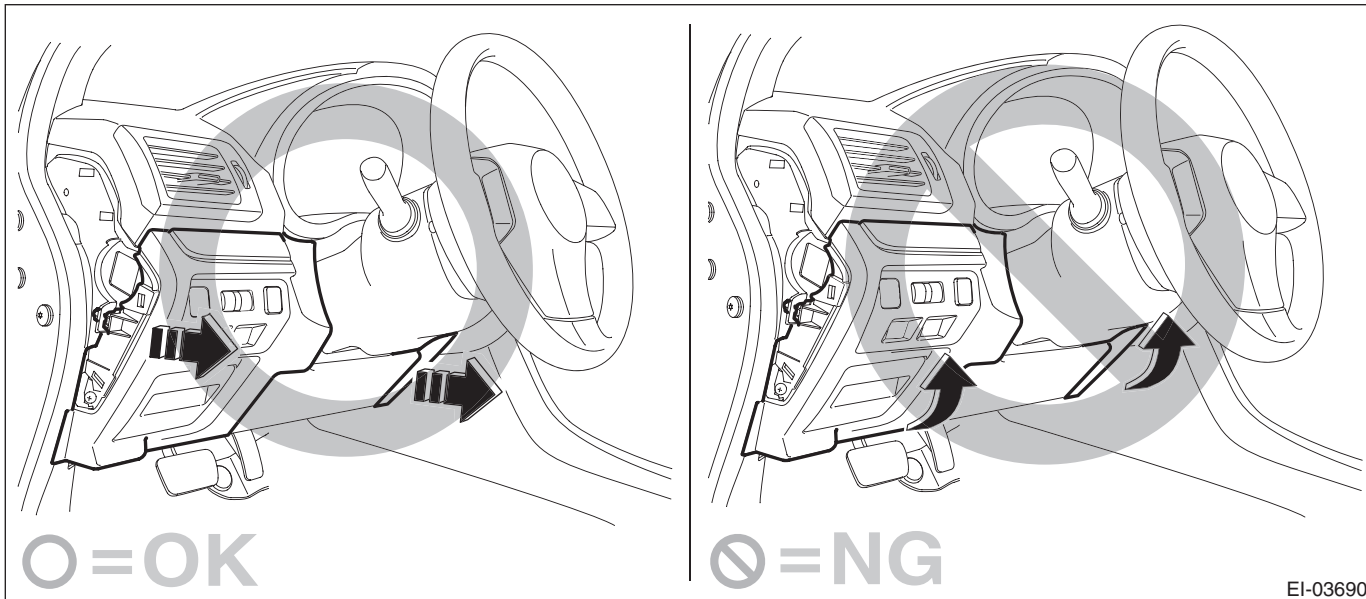

(1) Remove the clips, and remove the cover - instrument panel side LH.

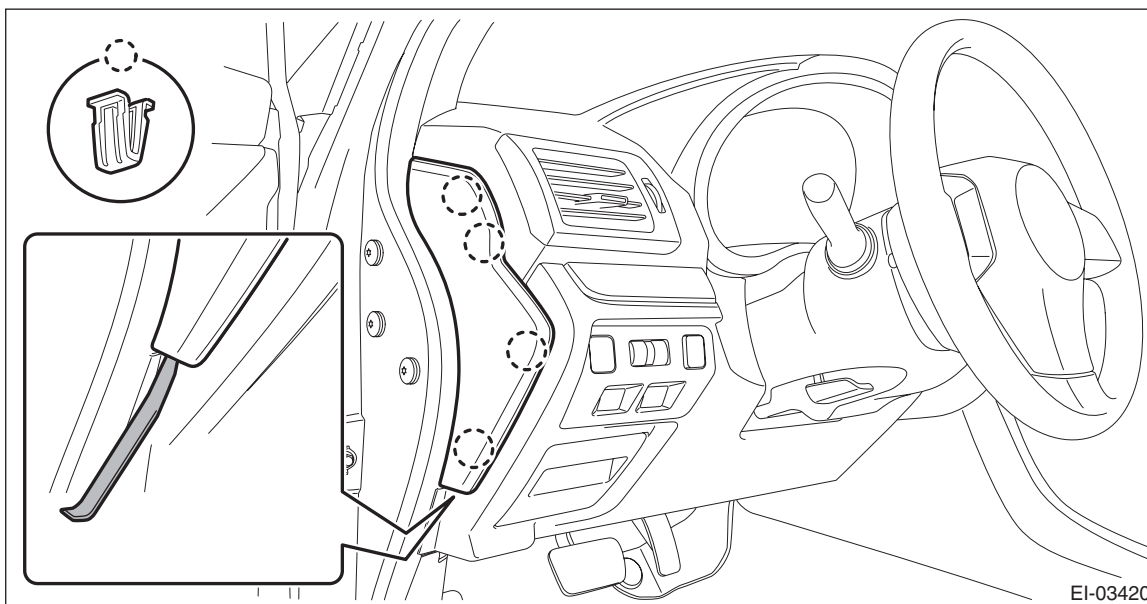

NOTE:

Using a plastic remover, open the cover - instrument panel side LH.

(2) Remove the screws and release the clips and claws.

Instrument Panel Assembly

EXTERIOR/INTERIOR TRIM

- (3) Disconnect the harness connectors, and remove the cover assembly - instrument panel LWR driver INN and OUT.

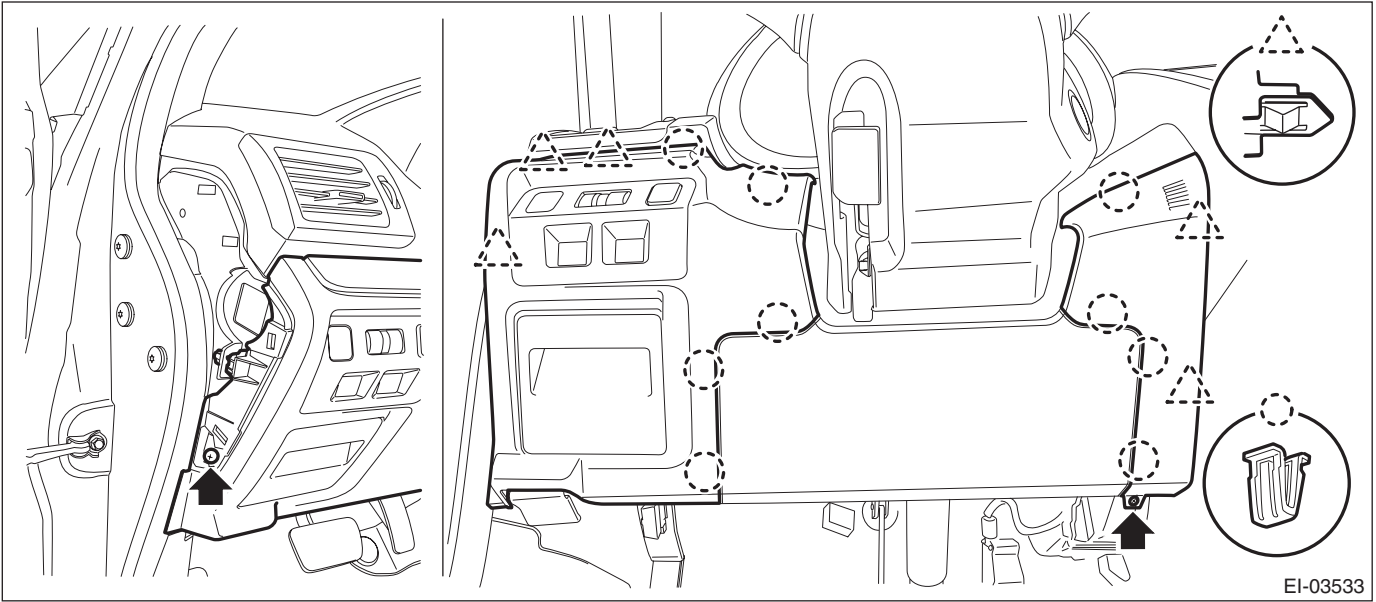

- 6) Remove the cover switch - starter.

- (1) Release the claws and remove the cover switch - starter.
(2) Disconnect the connector and aspirator hose.

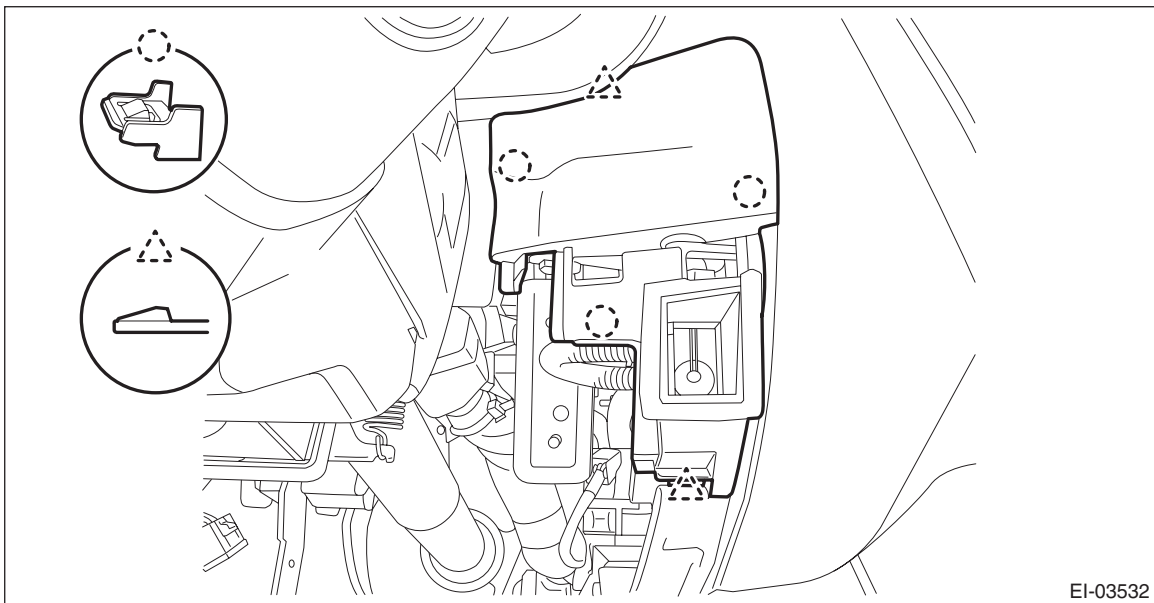

Instrument Panel Assembly

EXTERIOR/INTERIOR TRIM

7) Remove the nuts to remove the knee airbag module and disconnect the harness connector. <Ref. to AB-33, KNEE AIRBAG MODULE, PROCEDURE, Airbag Connector.>

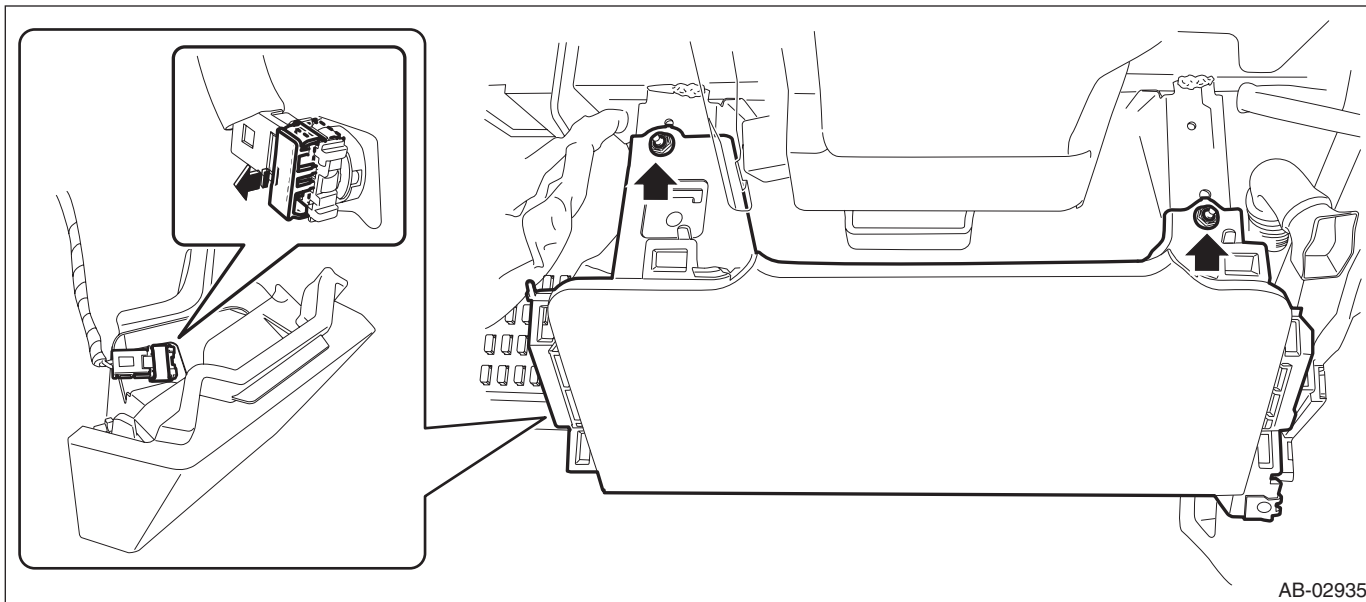

8) Release the clips and claws, then detach the left and right grille speaker side.

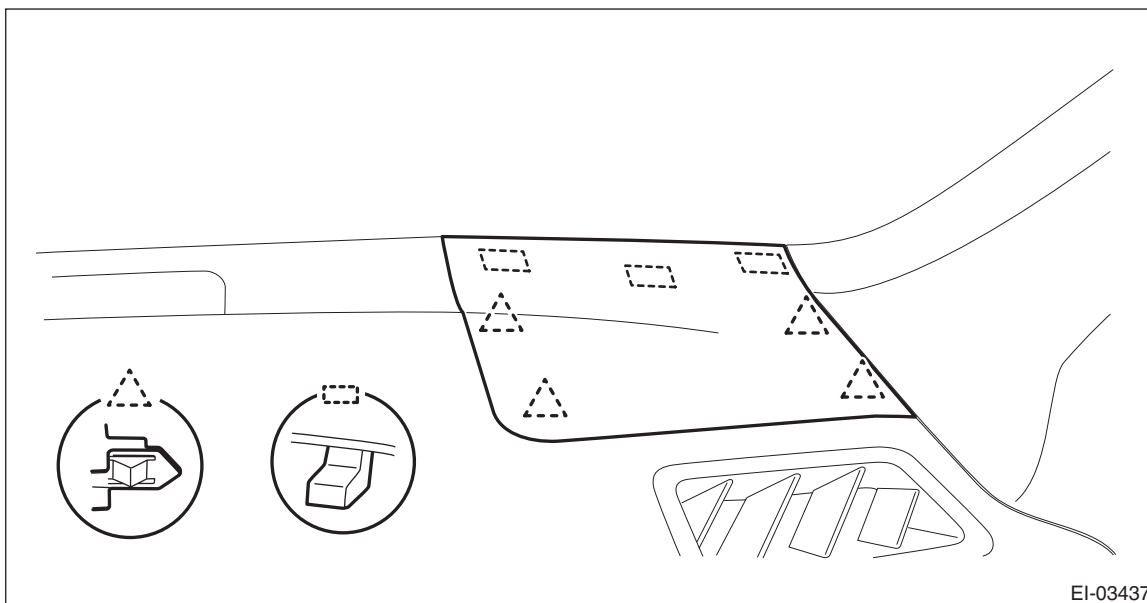

NOTE:
Remove the grille speaker side by using a plastic remover.

- 9) Remove the trim panel - front pillar UPR on the left and right sides.
- (1) Pull the upper part of the trim panel - front pillar UPR towards the center of the vehicle.
 - (2) Insert long-nose pliers into the top part of the trim, grip the tether clip with the pliers and twist 90° in that position.

CAUTION:

Be careful not to damage the pillar trim surface and curtain airbag module when inserting the pliers.

- (3) Holding the tether clip twisted as in the previous step, remove the trim panel - front pillar UPR from the tether clip.
- (4) Remove the clips, and remove the trim panel - front pillar UPR.

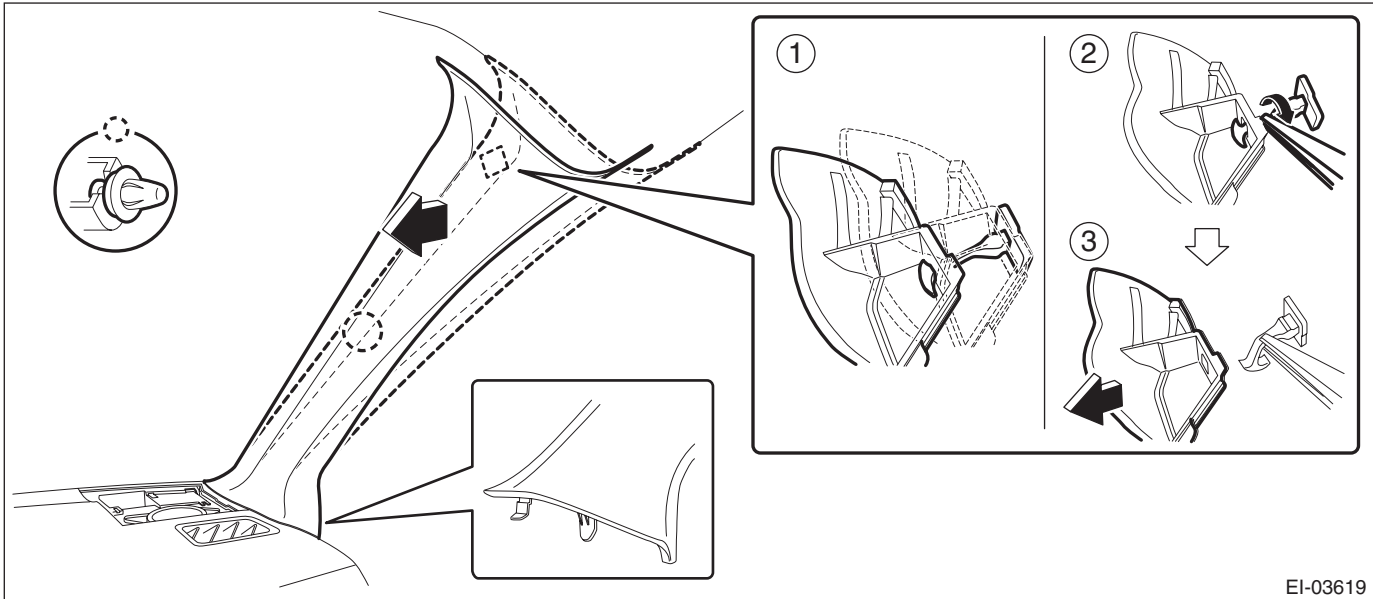

EI-03619

- 10) Remove the pocket assembly.
- (1) Attach the protective tape (a) to the panel center LWR.
 - (2) Remove the damper COMPL - pocket.
 - (3) Release the stoppers and remove the pocket assembly by pulling it toward you.

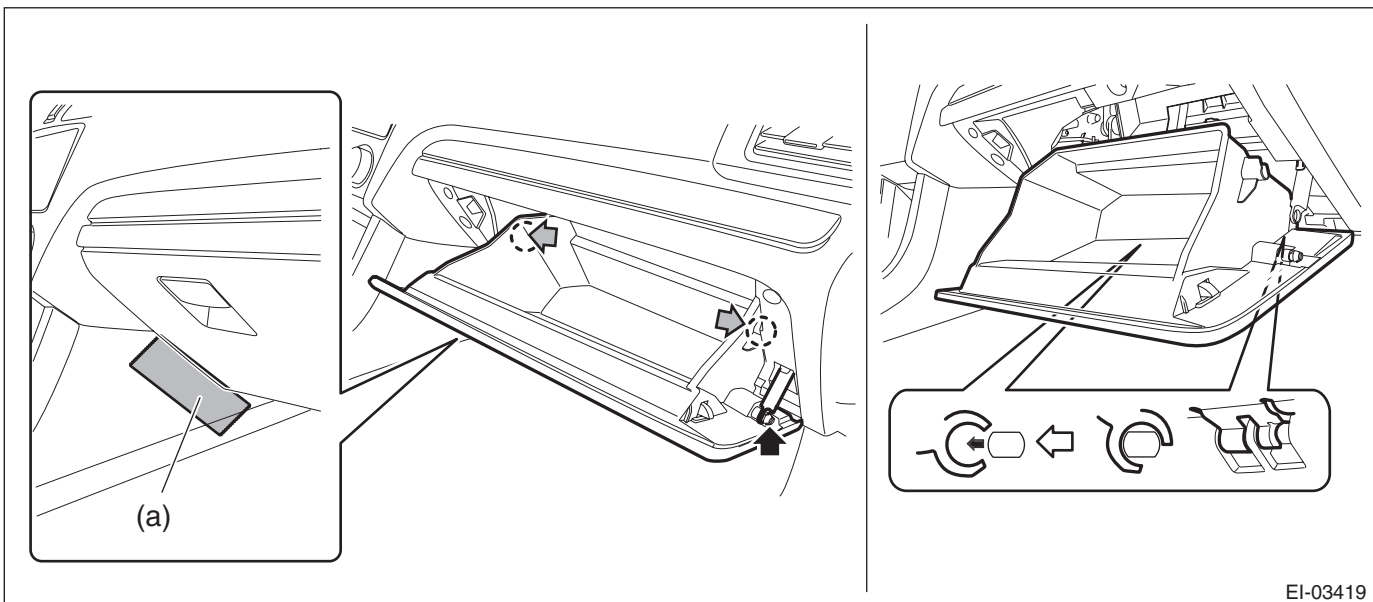

EI-03419

Instrument Panel Assembly

EXTERIOR/INTERIOR TRIM

11) Remove the back panel - pocket.

(1) Remove the clips, and remove the cover - instrument panel side RH.

NOTE:

Remove the cover - instrument panel side RH by using a plastic remover.

(2) Release the clips, and remove the ornament - panel assembly passenger.

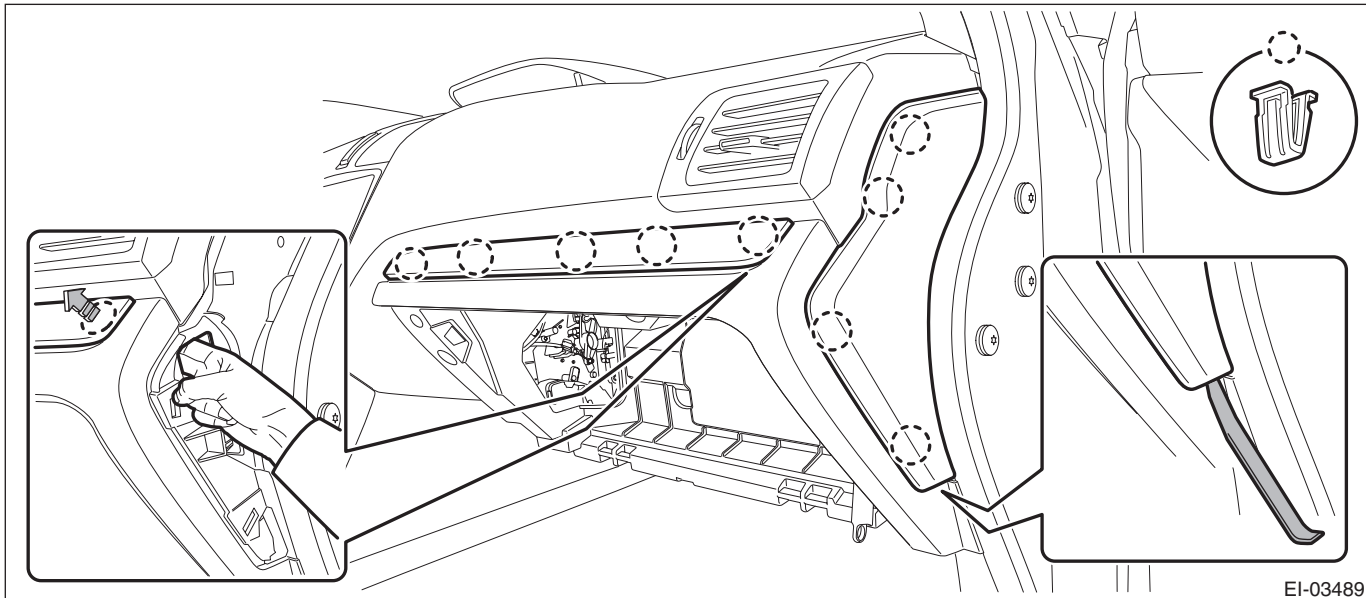

NOTE:

To facilitate the removal, push the clip of the ornament - panel assembly passenger from the backside.

(3) Remove the screws, claws and harness clamp, then remove the back panel - pocket.

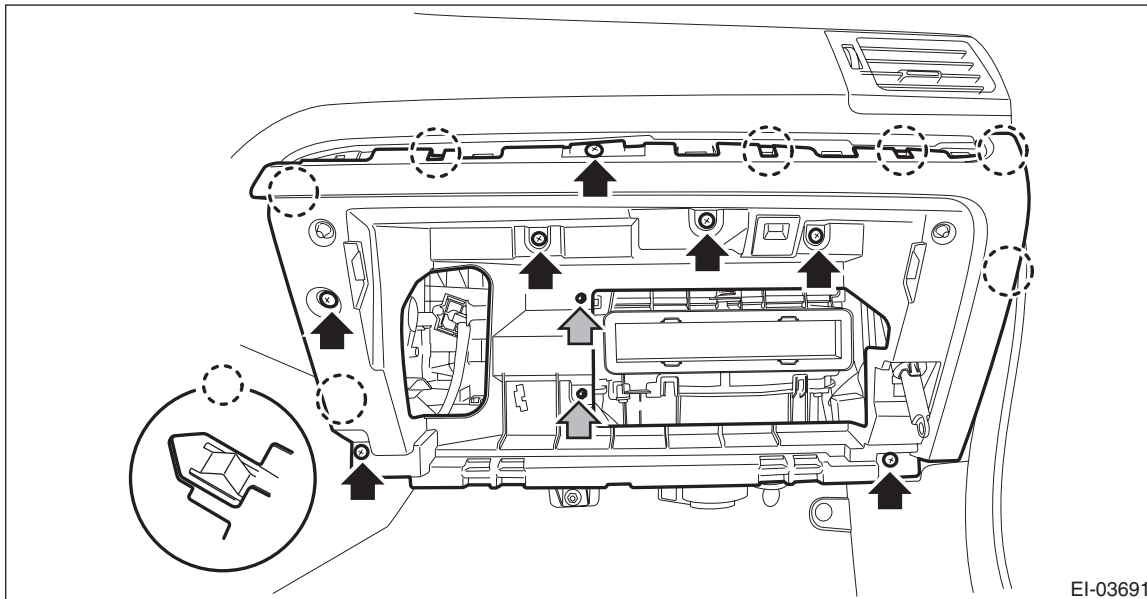

(4) Disconnect the glove box light LED connector.

12) On manual A/C models, disconnect the control cables from both sides of the heater & cooling unit.

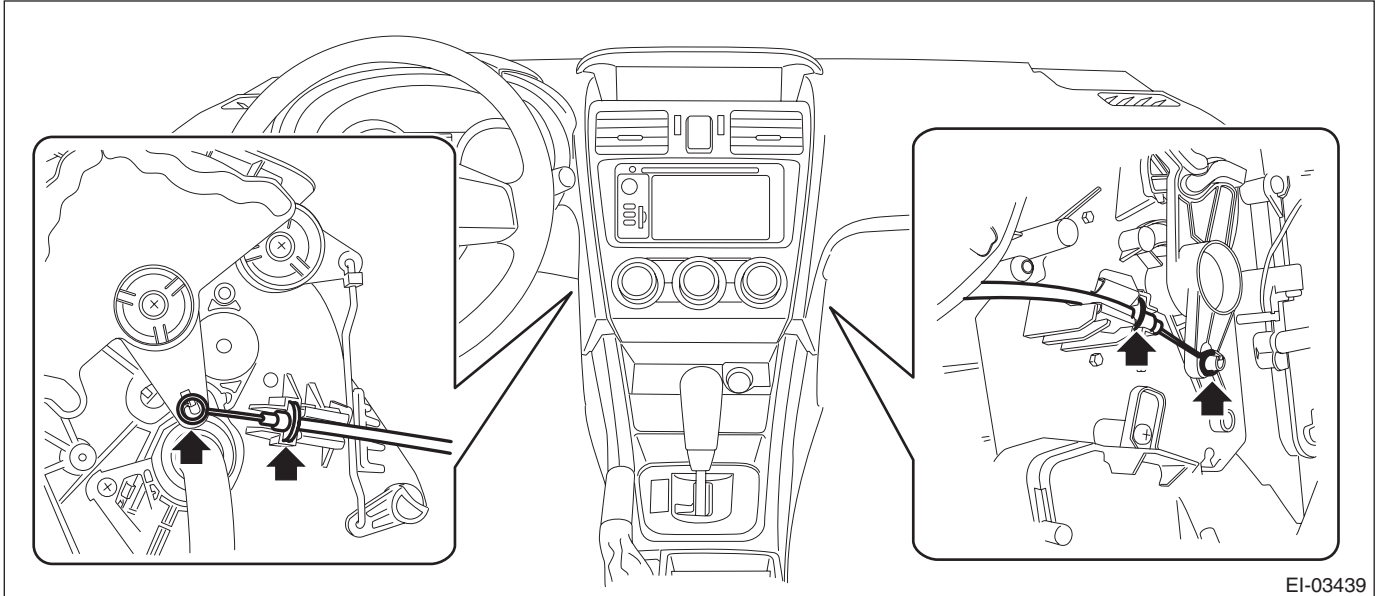

EI-03439

13) Remove the panel center assembly.

CAUTION:

- Do not put your finger on the fin of the air vent grille. Doing so may damage the fin.
 - Pull the panel center assembly slowly. Pulling with excessive force may damage the connector.
- (1) Insert a plastic remover to the three areas shown by the arrows, and lift up the panel center assembly slightly.
 - (2) With the panel center assembly lifted up slightly, release the claw by using a clip remover wrapped with protective tape.
 - (3) Release the rest of the claws, and pull out the panel center assembly.
 - (4) Disconnect the connectors, and remove the panel center assembly.

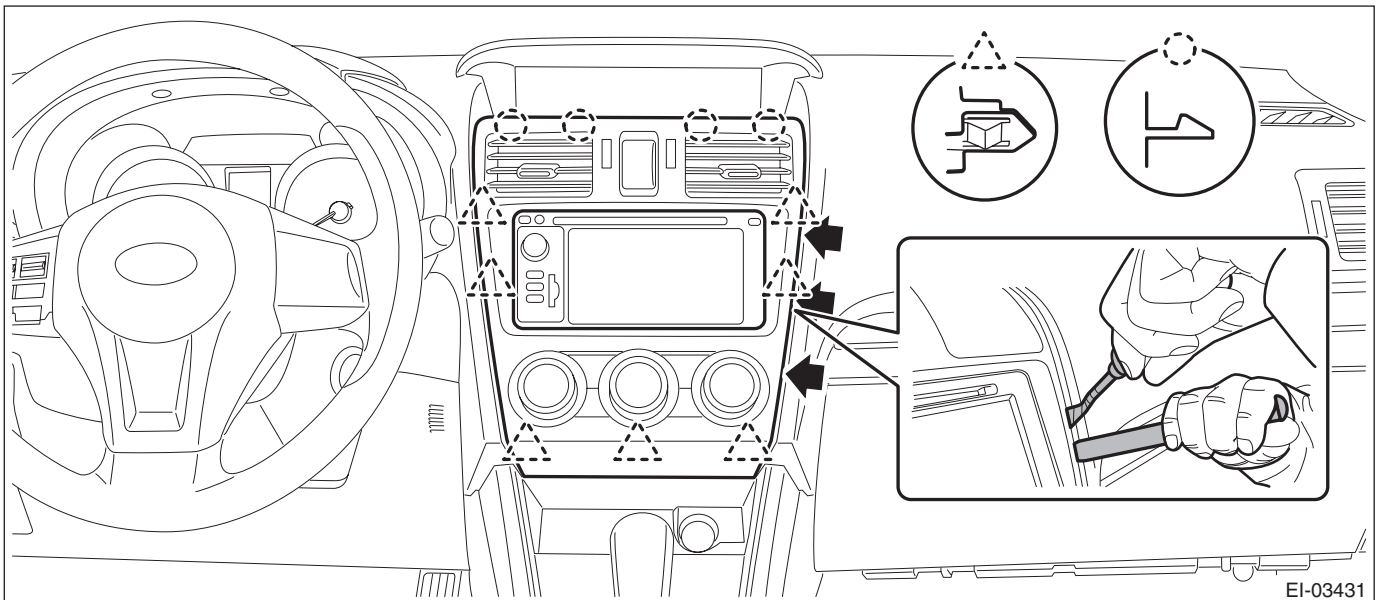

EI-03431

Instrument Panel Assembly

EXTERIOR/INTERIOR TRIM

- 14) Remove the audio assembly or navigation assembly.
- (1) Remove the screws, and partially pull out the audio assembly or navigation assembly.
 - (2) Disconnect the connectors, and remove the audio assembly or navigation assembly.

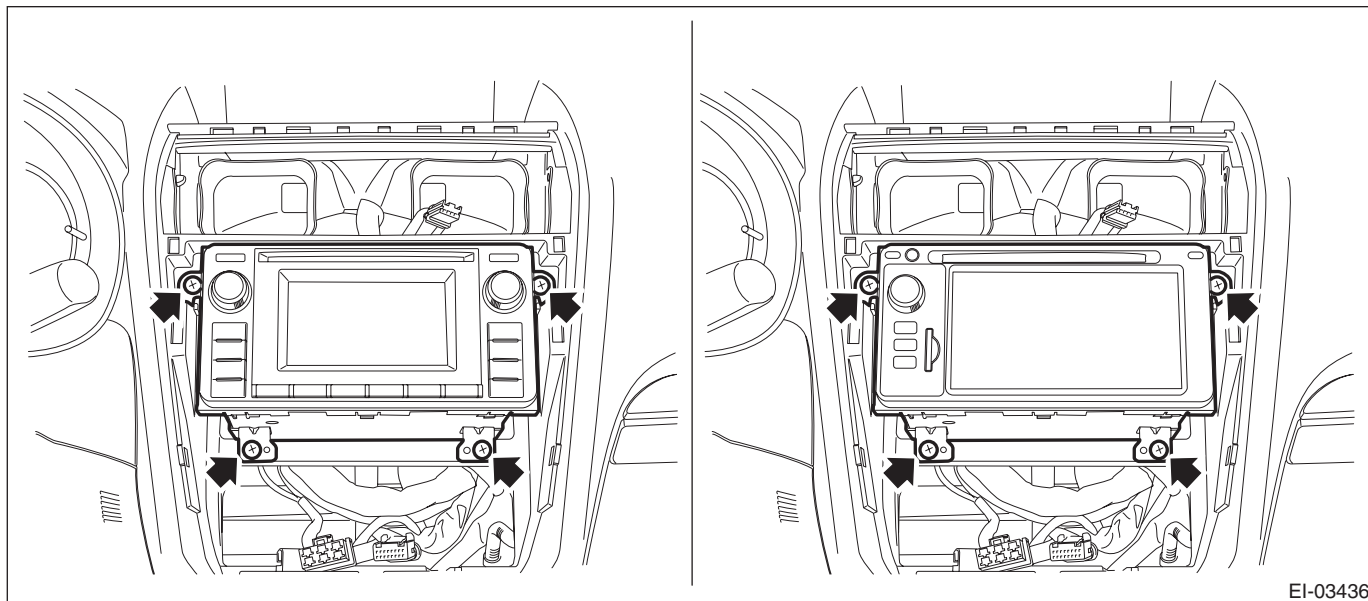

EI-03436

- 15) Remove the multi-function display assembly.
- (1) Disconnect the claws and then remove the cover center UPR.

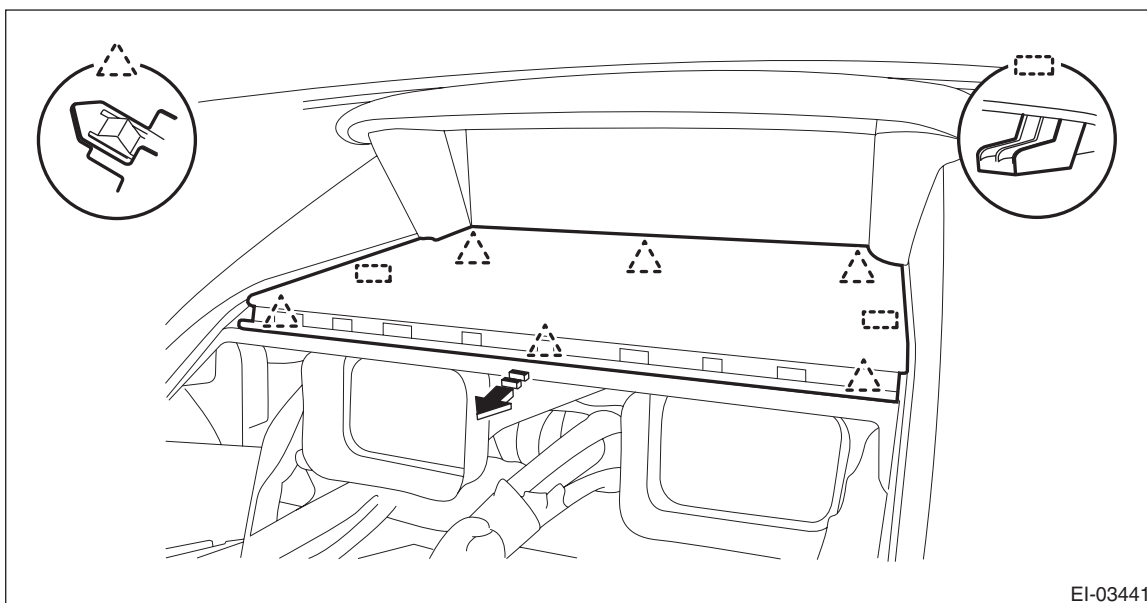

EI-03441

NOTE:

Lightly push up the back of the cover center UPR, hook the finger to the end portion and pull it toward you to remove it.

- (2) Remove the screws and release the claws, then remove the panel - display assembly.

NOTE:

Remove the panel - display UPR & panel - display LWR and the multi-function display assembly as a unit.

(3) Disconnect the connector and remove the multi-function display assembly.

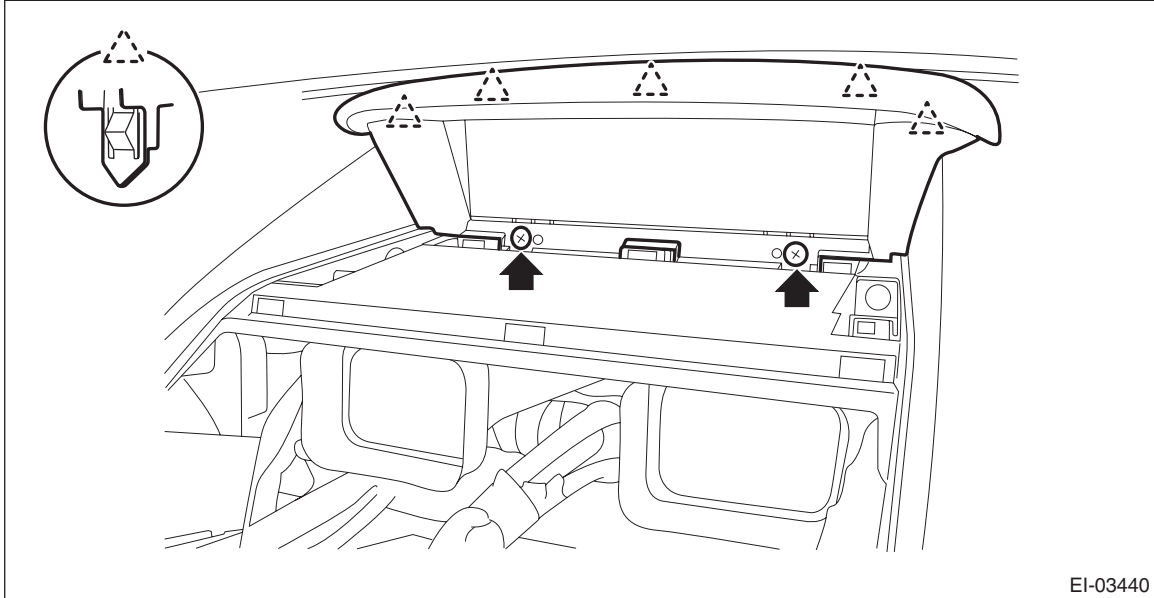

16) Remove the combination meter assembly.

CAUTION:

- Be careful not to damage the meter or instrument panel.
- Pay particular attention to avoid damaging the meter glass.

(1) Release the lock, tilt the steering column to the lowest end and fully extend the column by the telescopic system.

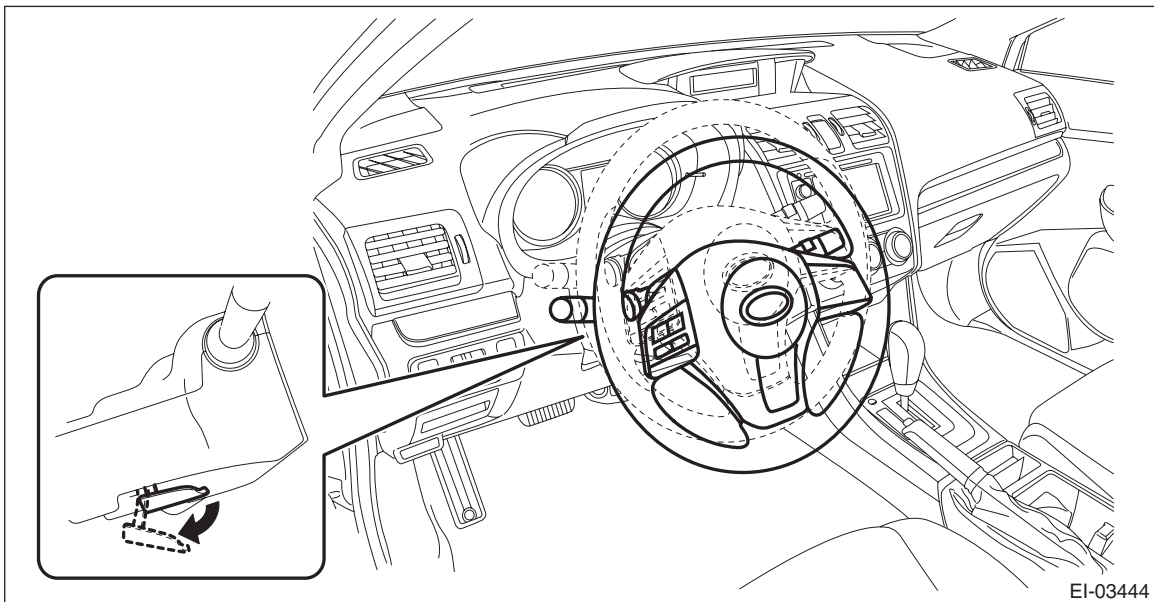

Instrument Panel Assembly

EXTERIOR/INTERIOR TRIM

- (2) Release the screws and clips, then detach the visor - combination meter.

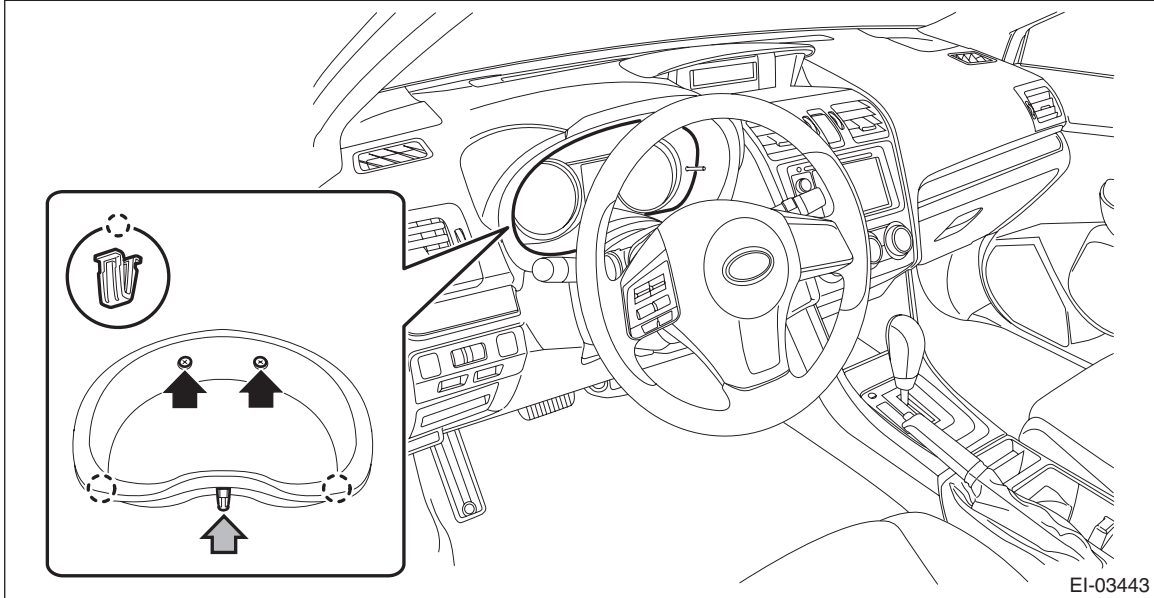

- (3) Remove the screws, disconnect the connector and remove the combination meter assembly.

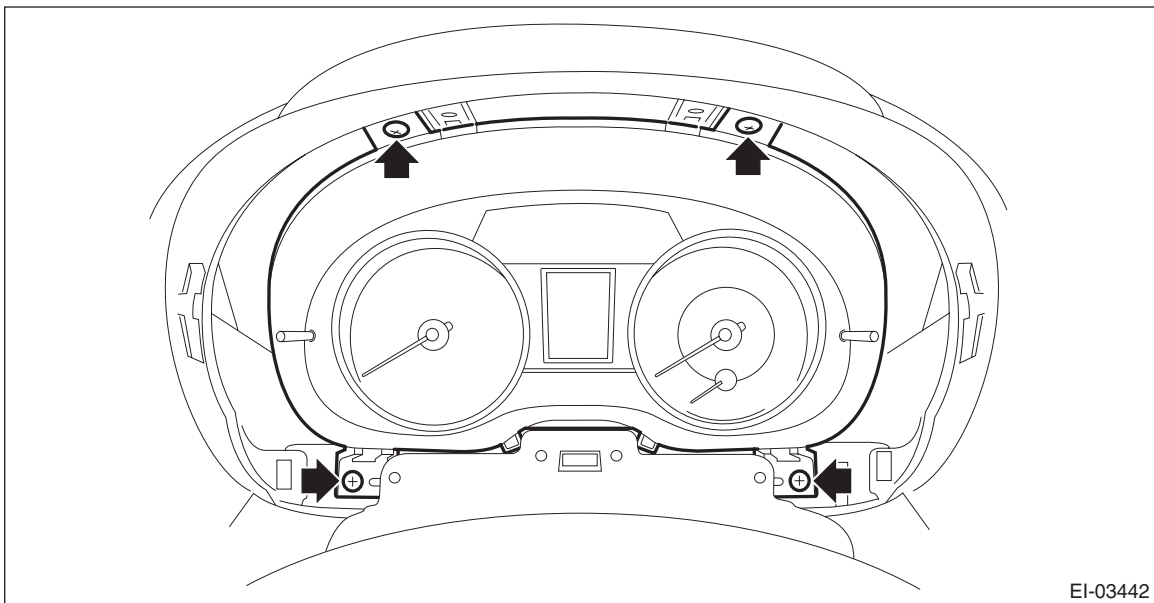

17) Disconnect the passenger's airbag module connector. <Ref. to AB-23, PASSENGER'S AIRBAG MODULE, PROCEDURE, Airbag Connector.>

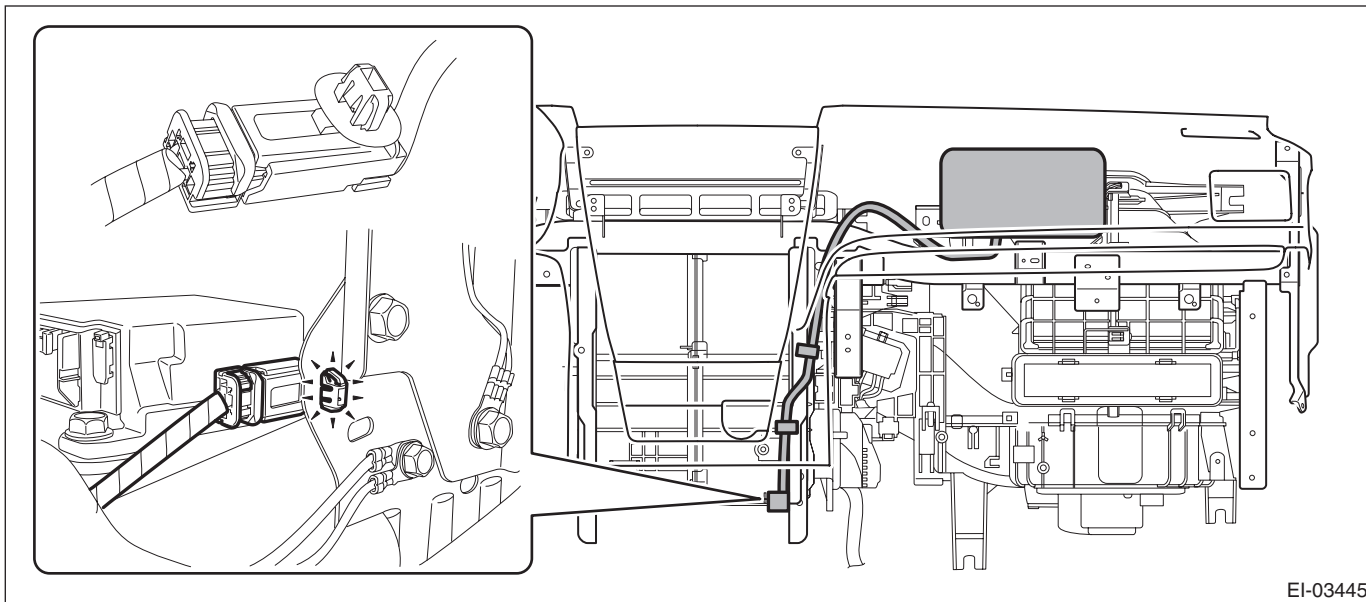

EI-03445

18) Remove the column assembly - steering. <Ref. to PS-18, REMOVAL, Steering Column.>

19) Release the claws, and then remove the cover side sill - front INN on LH and RH sides.

CAUTION:

Do not pull with excessive force. Doing so may damage the claws of the cover side sill - front INN.

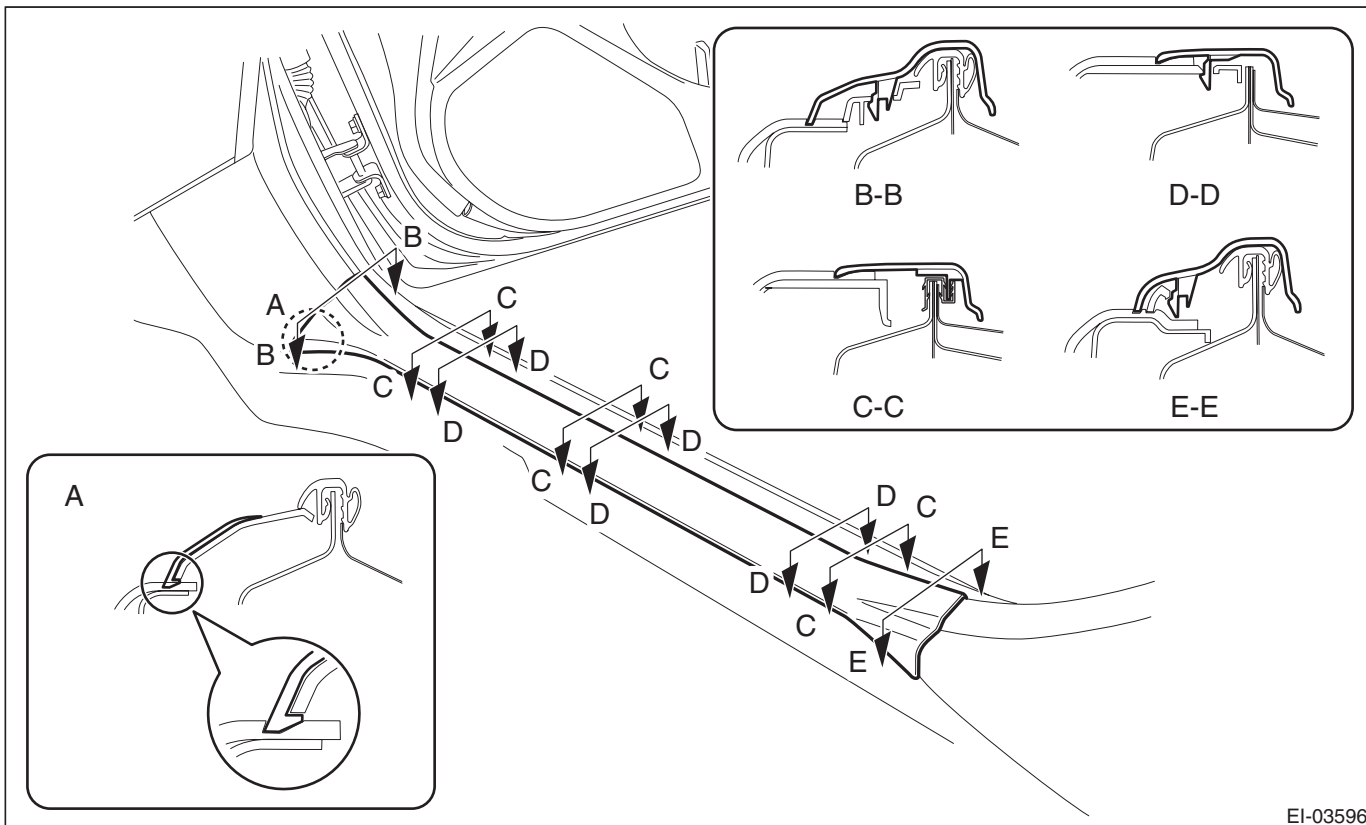

EI-03596

Instrument Panel Assembly

EXTERIOR/INTERIOR TRIM

20) Remove the clip, and remove the cover side sill - front on LH and RH sides.

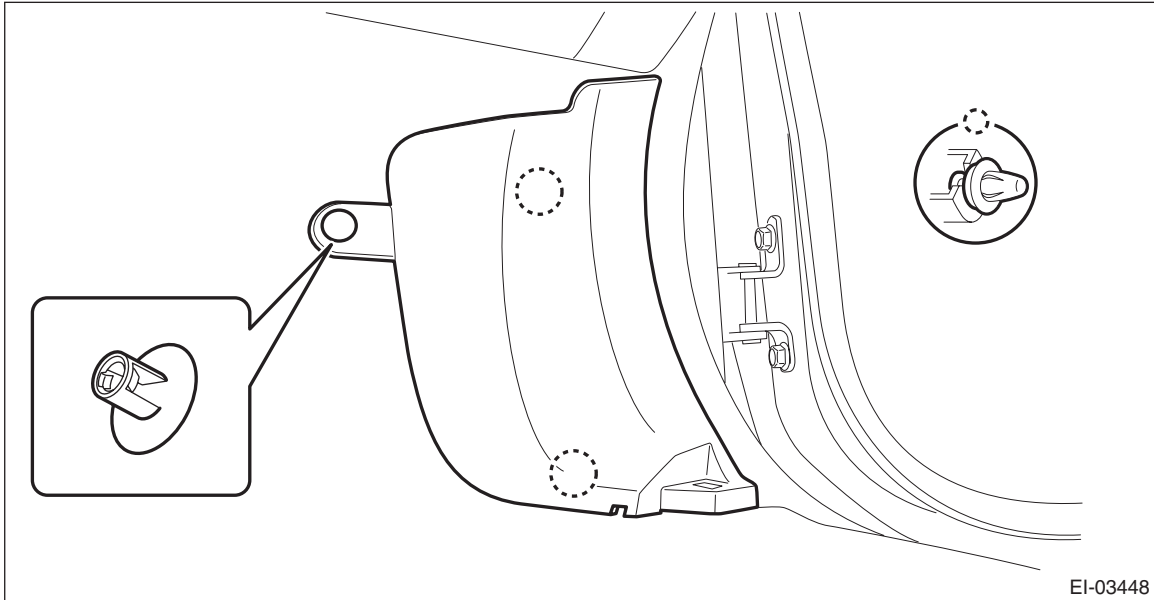

21) Remove the body side weather strip - flange front.

22) Remove the instrument panel assembly and the beam COMPL - steering as a unit.

CAUTION:

The instrument panel assembly and the beam COMPL - steering are heavy. Always work in a team of two persons when removing them from the vehicle, so as not to damage the vehicle interior.

- (1) Remove the fuse box and relay box.
- (2) Disconnect all harness clamps and connectors of the instrument panel harness.
- (3) Remove the TORX[®] bolt. (a), (b)

Preparation tool:

TORX[®] T40

- (4) Remove the bolts at the floor center. (c), (d)

(5) Remove the bolt. (e), (f)

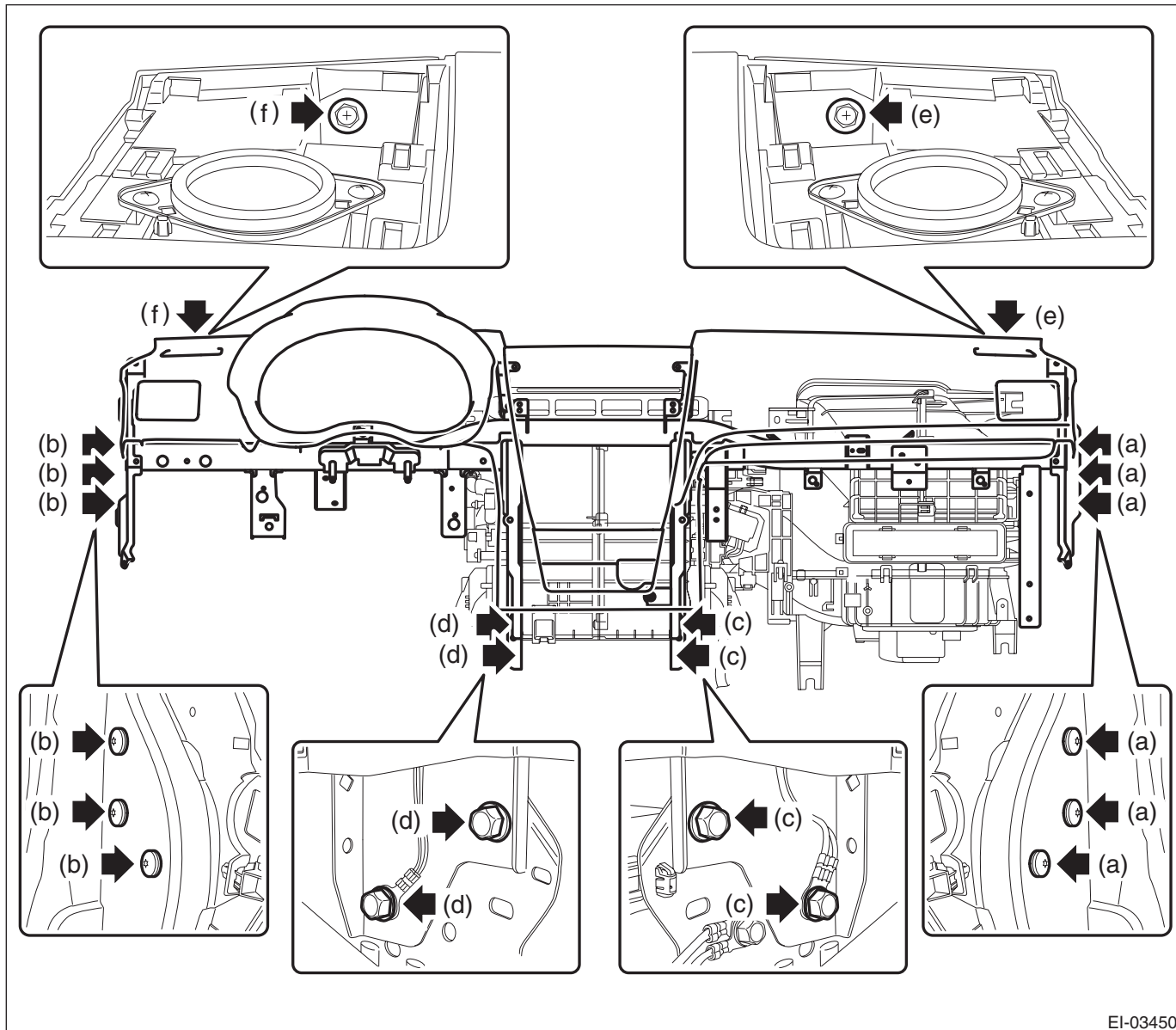

Instrument Panel Assembly

EXTERIOR/INTERIOR TRIM

(6) Loosen the adjuster portion (h) of the adjuster - clip space. (only LH side of the beam COMPL - steering)

Preparation tool:

Hexagon wrench: 8 mm (0.31 in)

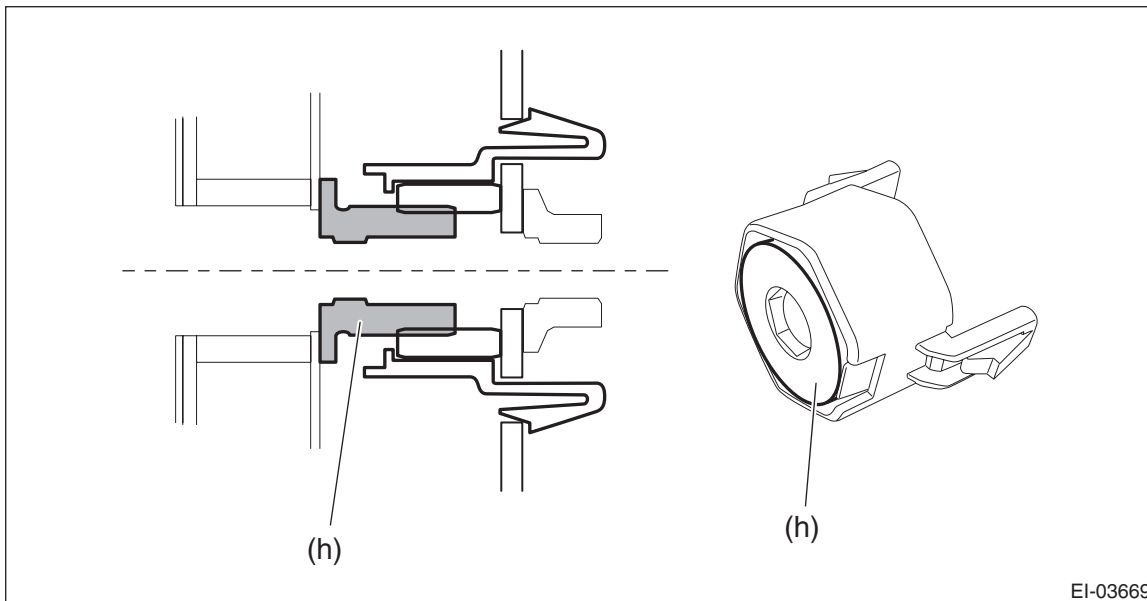

(7) Slightly lift the instrument panel assembly together with the beam COMPL - steering to detach the left and right pins. Then pull it toward you to remove the assembly.

CAUTION:

- Check that all harness clamps and connectors are detached.
- The instrument panel assembly and the beam COMPL - steering are heavy. Always work in a team of two persons when removing them from the vehicle, so as not to damage the vehicle interior.

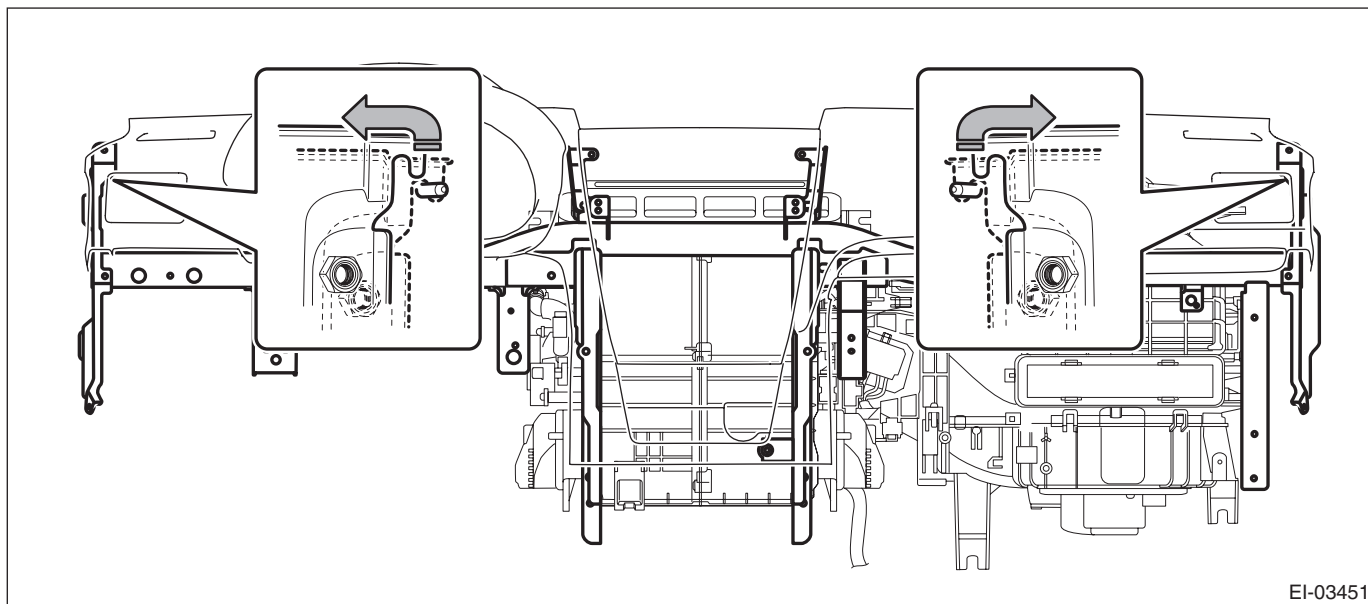

23) Remove the panel COMPL - instrument UPR.

(1) Disconnect the connector of the sensor - sunload.

(2) Release the claws, and remove the panel COMPL - instrument UPR.

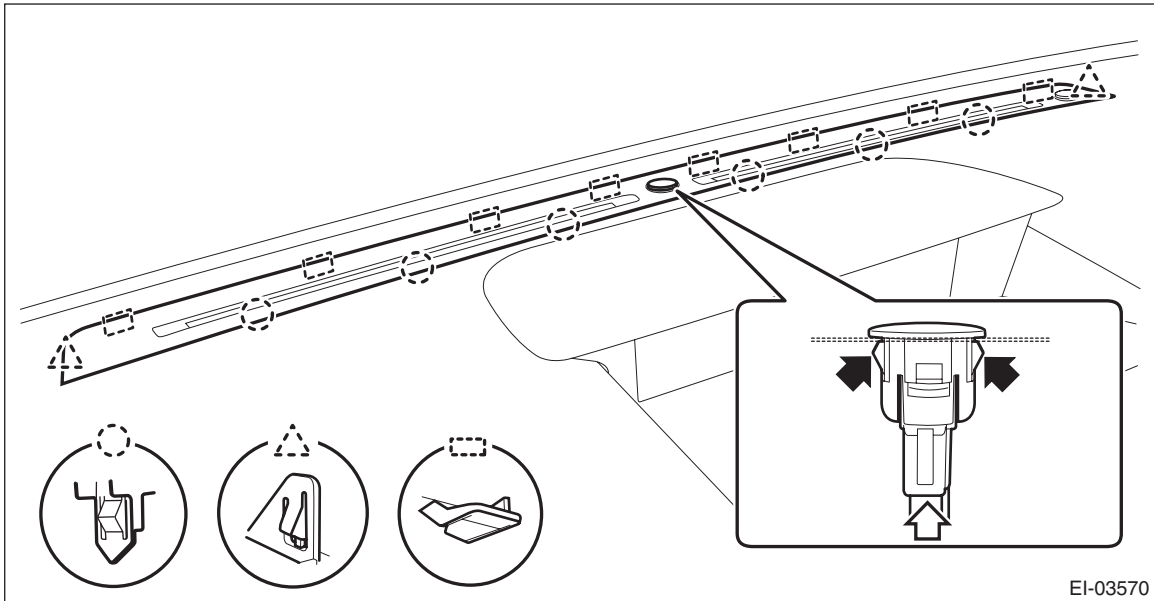

24) Remove the screws and remove the front (A) and side vent duct (B) LH, RH.

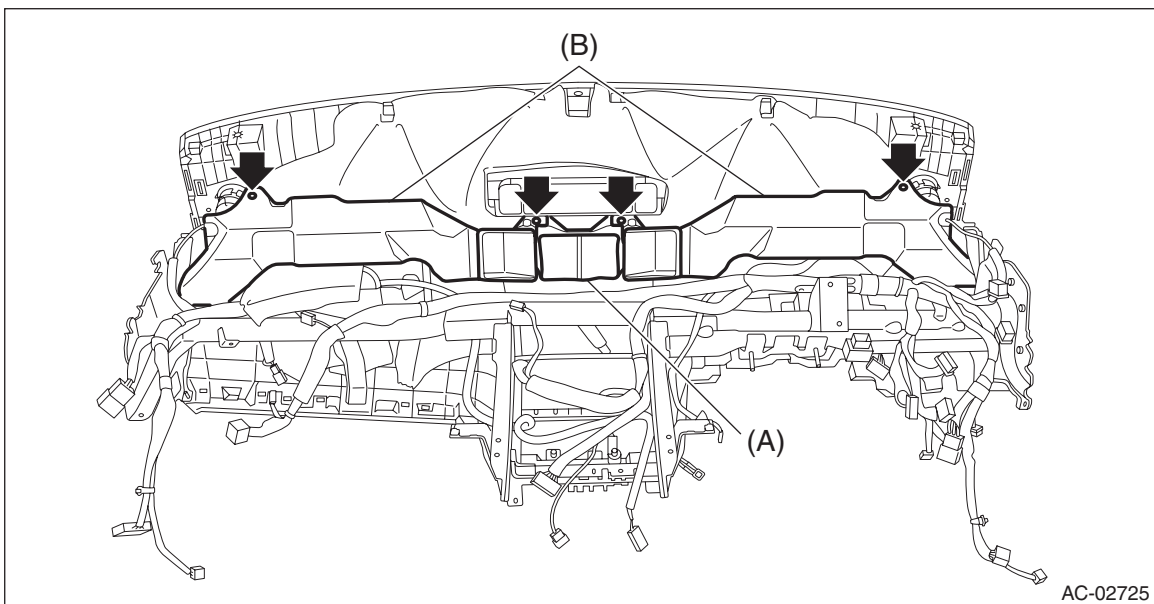

Instrument Panel Assembly

EXTERIOR/INTERIOR TRIM

- 25) Separate the panel COMPL - instrument and the beam COMPL - steering.
(1) Remove the clamps and bolts of the passenger's airbag module harness.

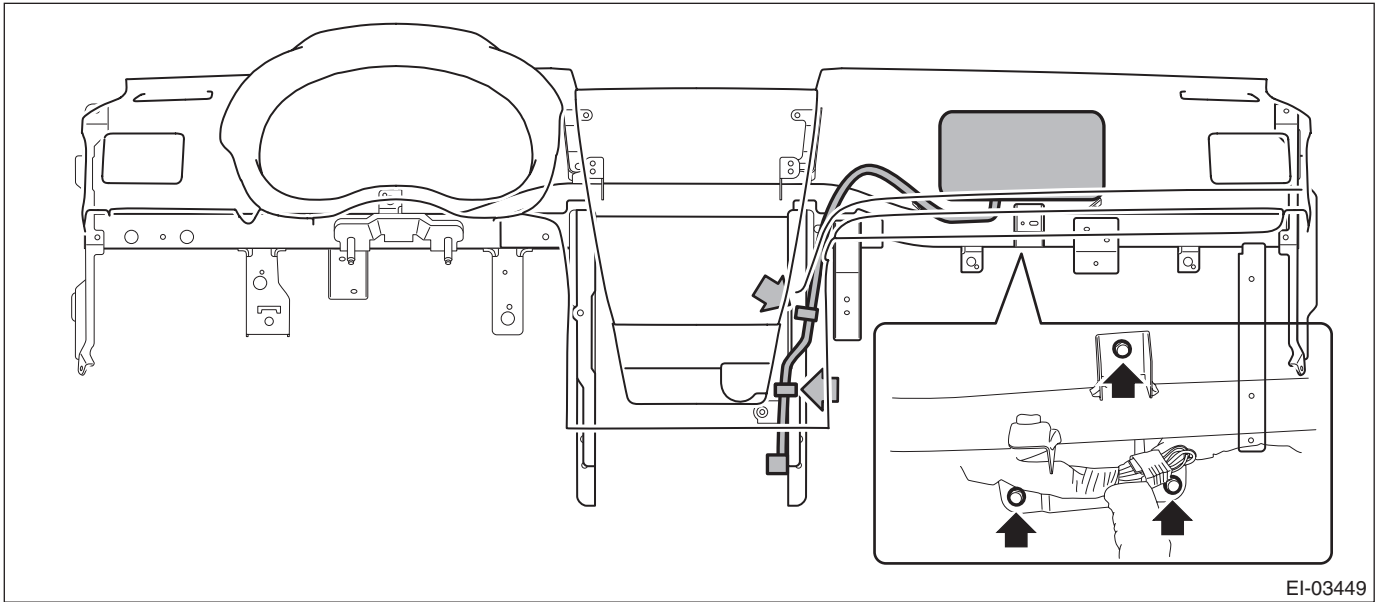

- (2) Remove the left and right speakers.

NOTE:

Detach the harness clamp together.

- (3) Disconnect the front accessory socket connector.
(4) Remove the nut (a) and screws (b), (c), (d), (e), (f), (g) and (h).

Instrument Panel Assembly

EXTERIOR/INTERIOR TRIM

(5) While being careful with the harness, separate the panel COMPL - instrument and the beam COMPL - steering.

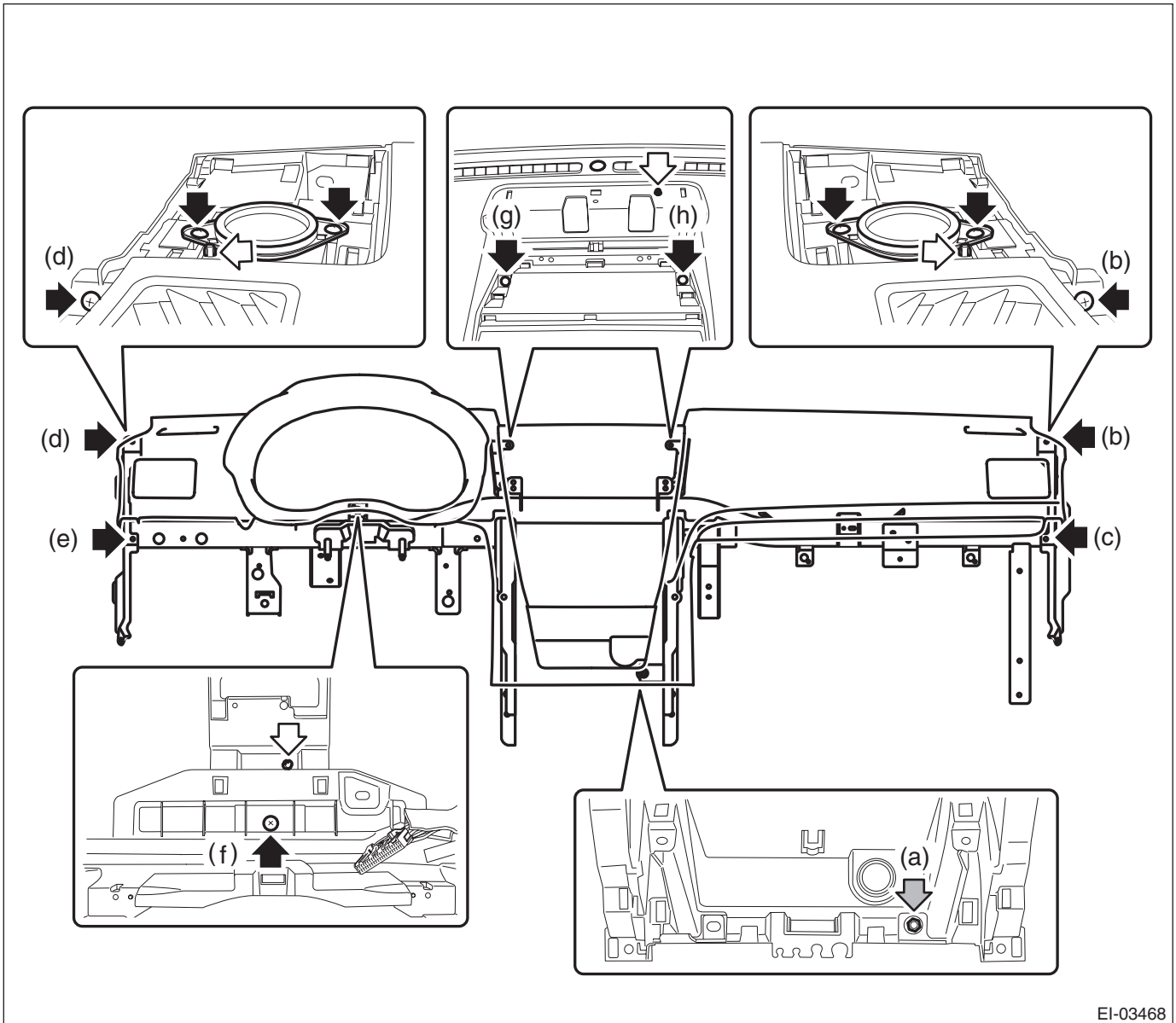

EI-03468

Instrument Panel Assembly

EXTERIOR/INTERIOR TRIM

26) Remove the claws, and remove the passenger's airbag module.

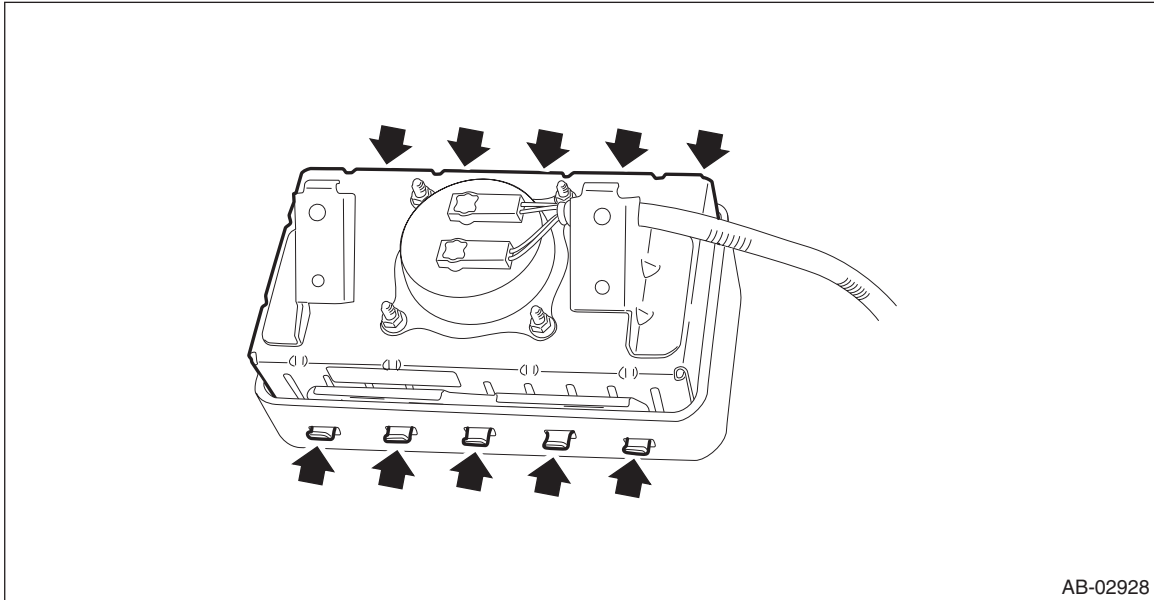

B: INSTALLATION

1) Attach components until the instrument panel assembly is formed, in the reverse order of removal.

Tightening torque:

Passenger's airbag module: 7.5 N·m (0.76 kgf-m, 5.5 ft-lb)

NOTE:

Method of installing insulator

- Adhesive

Use polyurethane adhesive. When assembling the instrument panel assembly, wait until the adhesive has evaporated to prevent filling of the smell in the compartment.

- Double-sided tape

Use commercial double-sided tape. (Use strong double-sided adhesive tape.)

2) Insert the matching pins on the body side (three locations - one in the center and the remaining two on both sides) into the instrument panel assembly and the beam COMPL - steering.

3) Check that the matching pins are inserted securely, and then route the harness.

- 4) Secure the instrument panel assembly and the beam COMPL - steering to the vehicle body.
 (1) Position the instrument panel assembly and the beam COMPL - steering to the vehicle body and tighten the adjuster - clip space.

Preparation tool:

Hexagon wrench: 8 mm (0.31 in)

NOTE:

Tighten so that there is no gap between the adjuster portion (h) and the body.

Tightening torque:

Adjuster - clip space: 0.4 — 4 N·m (0.04 — 0.41 kgf·m, 0.3 — 2.95 ft·lb)

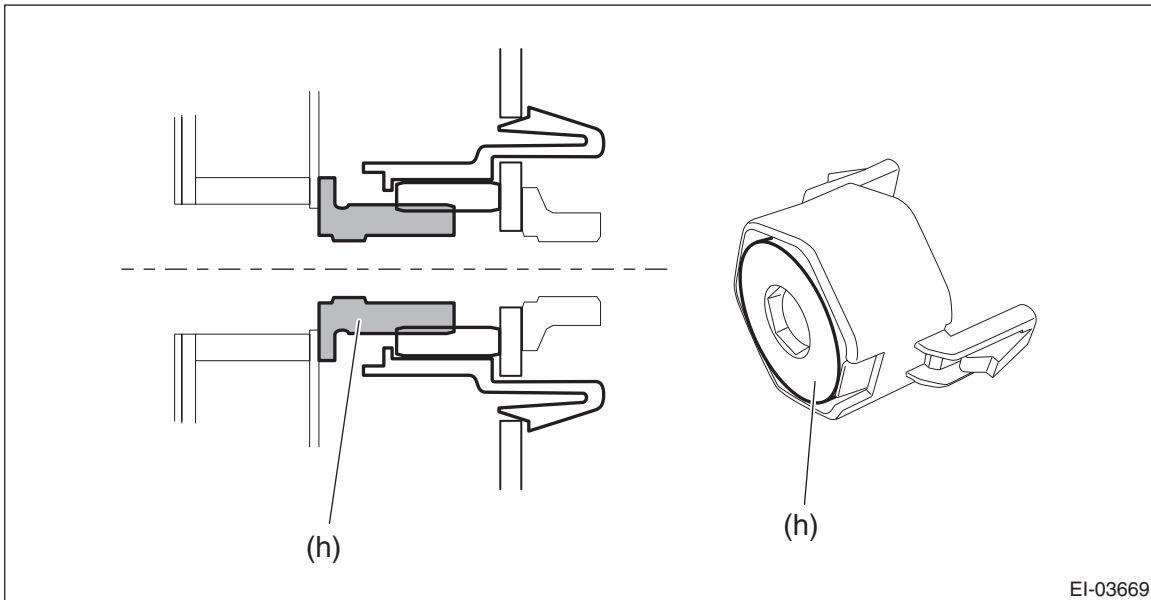

EI-03669

- (2) Temporarily tighten the bolts (a), (b), (c) and (d) of the beam COMPL - steering.

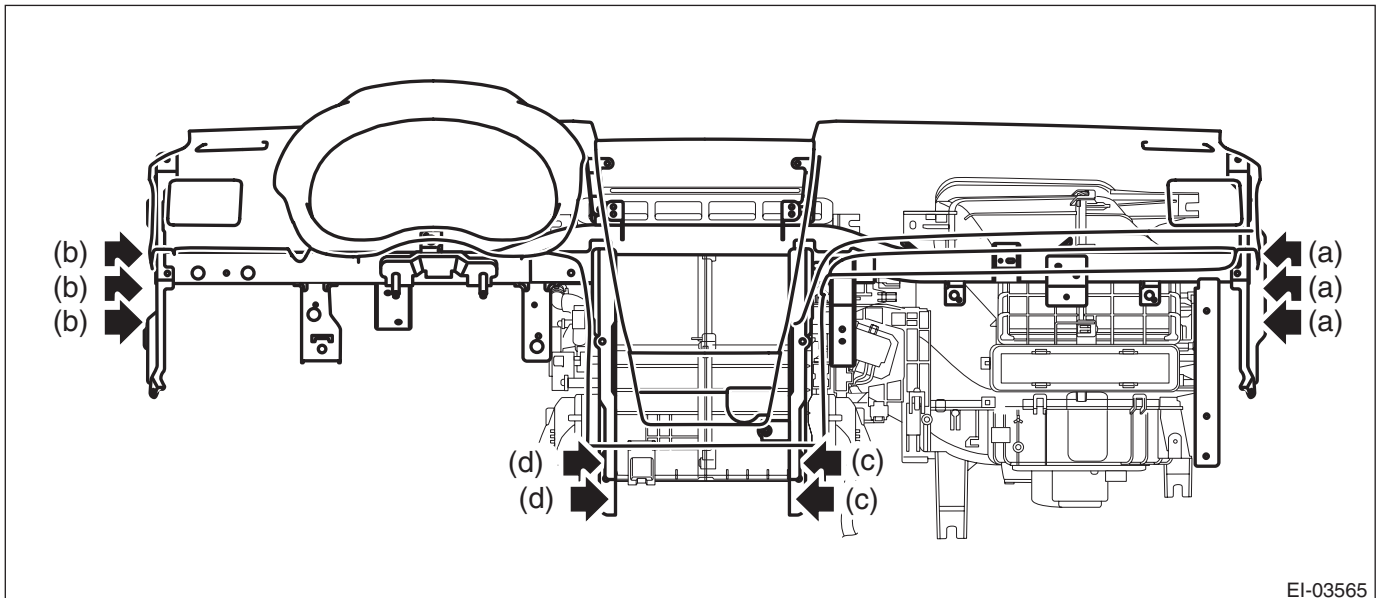

EI-03565

- (3) Tighten the beam COMPL - steering in the order from (a) to (d) to the specified torque.

Tightening torque:

Beam COMPL - steering: 25 N·m (2.55 kgf·m, 18.4 ft·lb)

Instrument Panel Assembly

EXTERIOR/INTERIOR TRIM

5) Install each part in the reverse order of removal.

CAUTION:

- After installing the panel center assembly, check that the air vent grille of the panel center assembly is inserted correctly into the air vent duct.
- When installing the cover - instrument panel side (a), make sure that the body side weather strip - flange front does not come inside the panel COMPL - instrument (b).

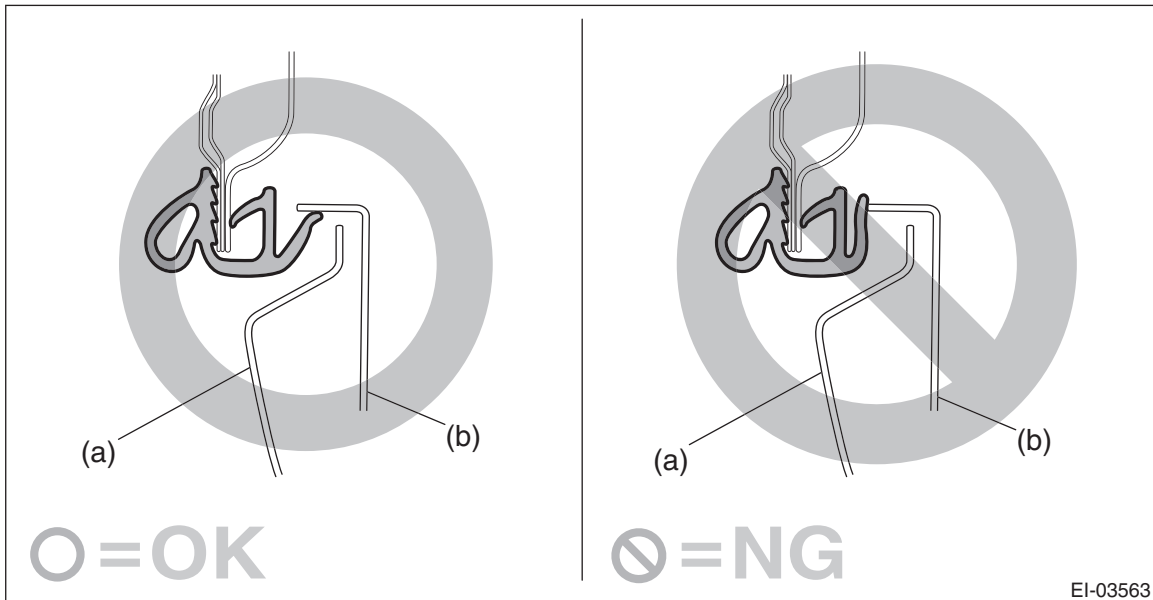

- When reusing the tether clip on the upper part of the trim panel - front pillar UPR, check that there is no damage to the tether clip. If the tether clip is damaged, its holding force is reduced and the trim panel - front pillar UPR may come off. Be sure to replace it with a new tether clip.
- Do not reuse the tether clip removed from the upper part of the trim panel - front pillar UPR. Always replace with a new part.
- Check the installation status of the tether clips and install the trim panel - front pillar UPR.

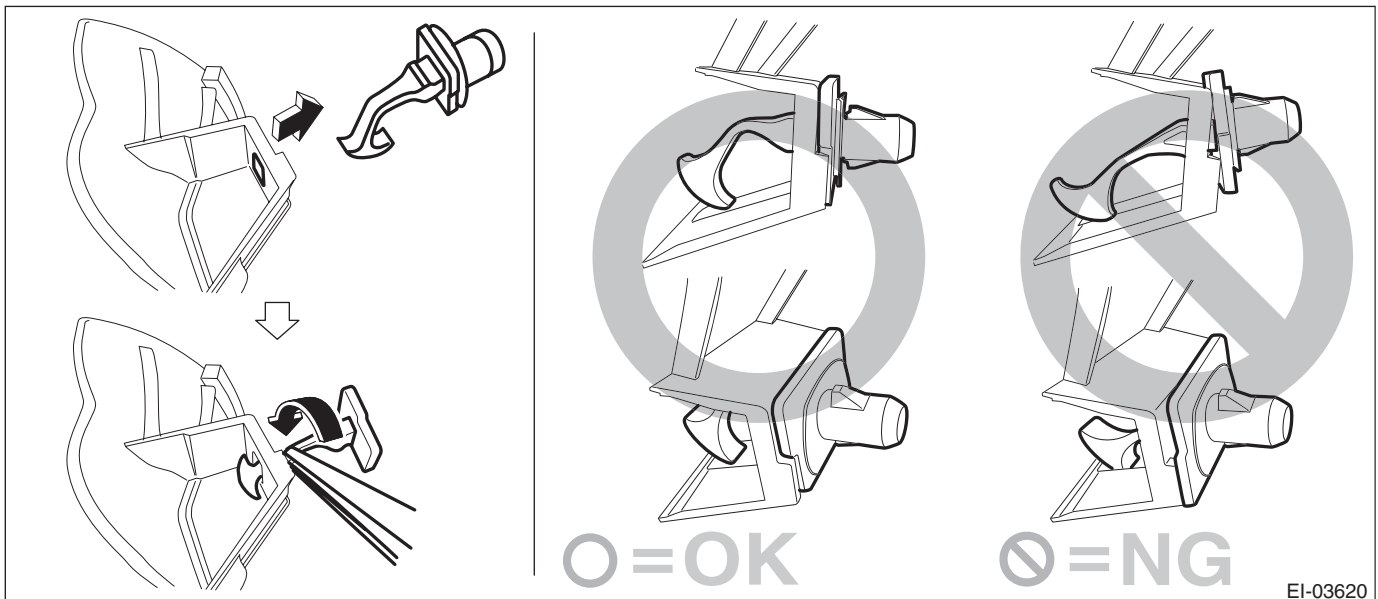

Tightening torque:

Column assembly - steering: <Ref. to PS-3, STEERING WHEEL AND COLUMN, COMPONENT, General Description.>

Console box assembly: 6.5 N·m (0.66 kgf·m, 4.8 ft·lb)