

# Rear Door

## EXTERIOR BODY PANELS

### 6. Rear Door

#### A: REMOVAL

##### 1. REAR DOOR PANEL

- 1) Disconnect the ground cable from battery.
- 2) Remove the trim panel - rear door.
  - (1) Open the cover and remove the screw.
  - (2) Remove the clips, and remove the trim panel - rear door from the panel assembly - rear door.

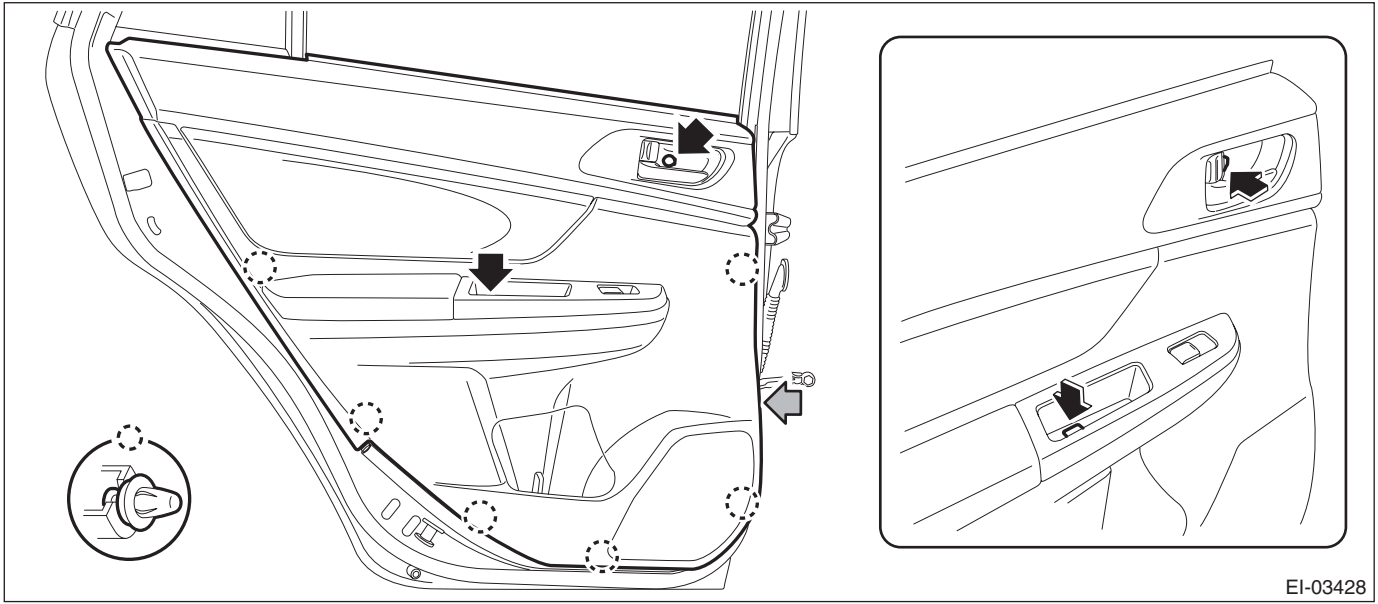

#### NOTE:

It is easier to remove the trim panel - rear door if the removal is performed from the gray arrow section.

- (3) Detach the door lock cable (a) and door open cable (b) from the remote assembly - door.

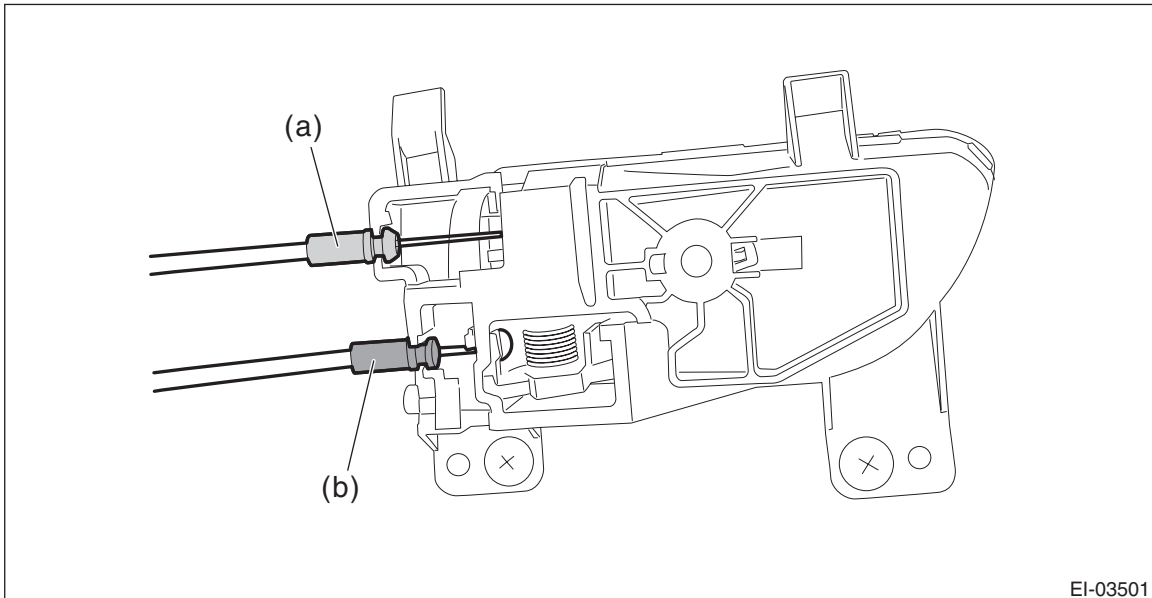

- (4) Disconnect the harness connector and remove the trim panel - rear door.

3) Remove the sealing cover - rear door.

**CAUTION:**

- Carefully remove the butyl tape. Excessive force will easily break the cover.
- If the sealing cover - rear door gets broken, replace it with a new part.
  - (1) Remove the screw to remove the bracket - door trim rear.
  - (2) Carefully remove the butyl tape to remove the sealing cover - rear door.

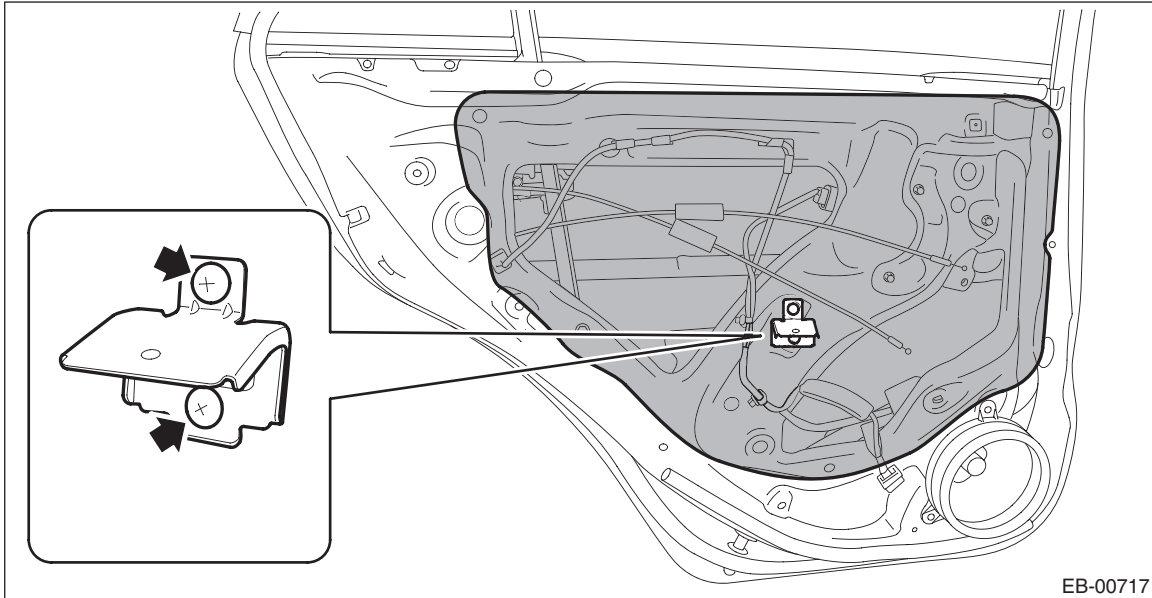

4) Remove the B pillar upper clip.

- 4 door model

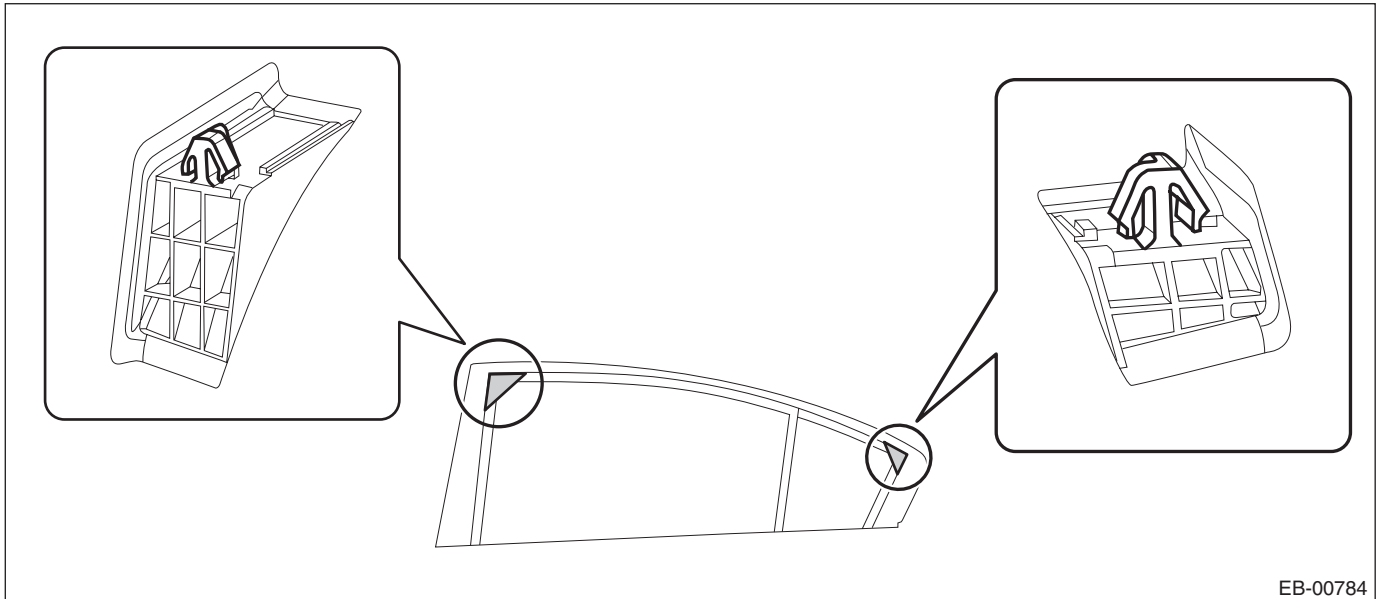

## Rear Door

### EXTERIOR BODY PANELS

- 5 door model/XV model

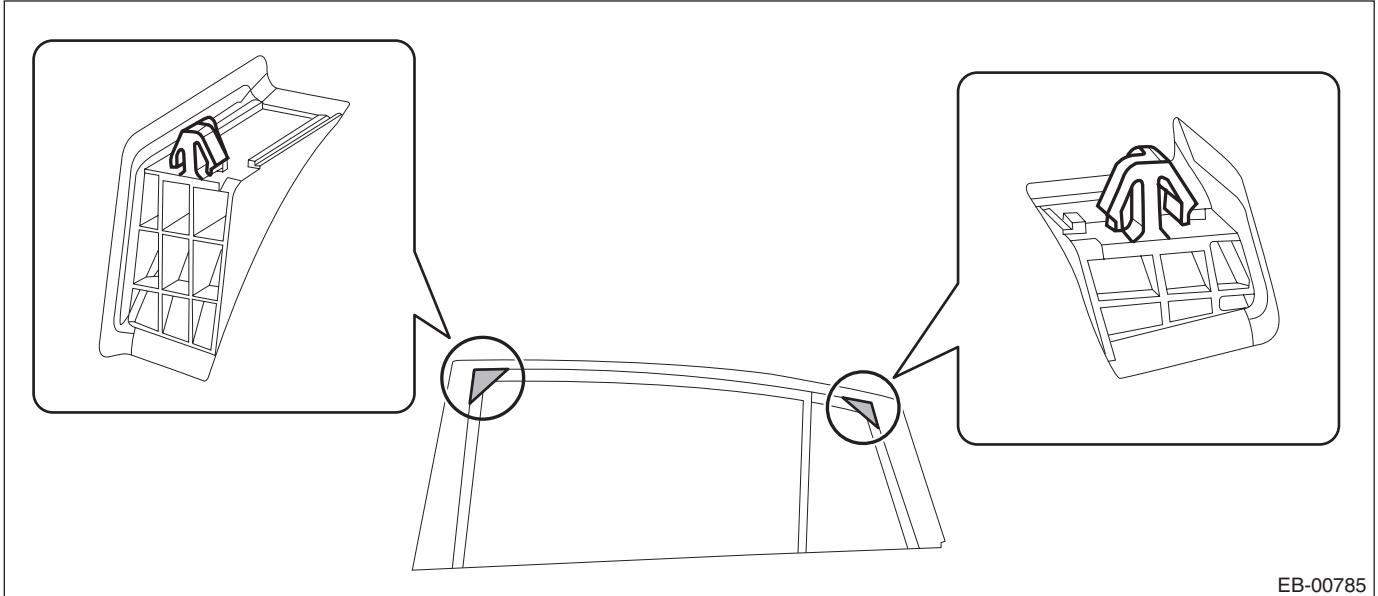

5) Remove the rear door speaker assembly.

- (1) Remove the screws.
- (2) Disconnect the connector behind the speaker and remove the rear speaker assembly.

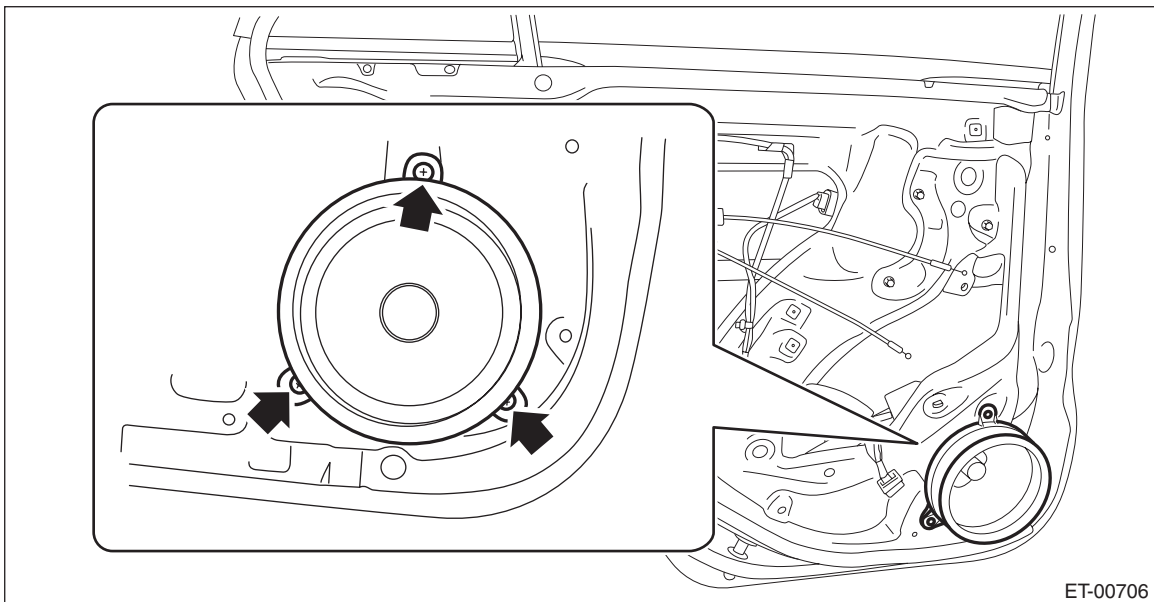

6) Remove the sash COMPL - rear partition and the glass assembly - rear door. <Ref. to GW-34, REMOVAL, Rear Door Glass.>

7) Remove the regulator - rear. <Ref. to GW-36, REMOVAL, Rear Regulator and Motor Assembly.>

8) Remove the latch and actuator assembly - rear. <Ref. to SL-44, REMOVAL, Rear Door Latch and Door Lock Actuator Assembly.>

9) Remove the cover - handle rear outer. <Ref. to SL-40, REMOVAL, Rear Outer Handle.>

10) Remove the rear door weather strip.

**CAUTION:**

If the weather strip clip is removed with excessive force, the weather strip may be damaged. Be sure to use clip remover to remove.

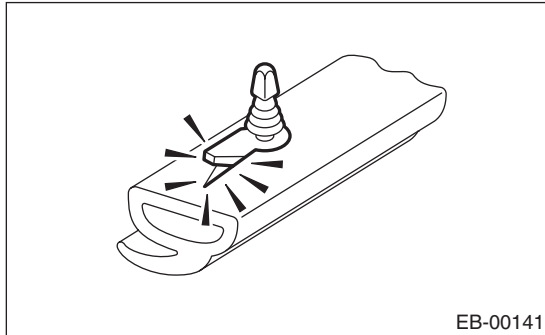

11) Remove the bolts and nuts, and then detach the checker assembly - rear door.

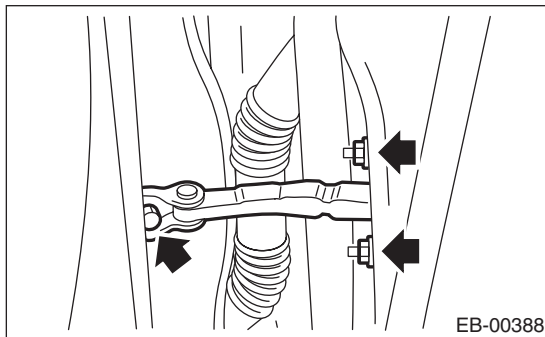

12) Disconnect the rear door harness connectors.

(1) Remove the grommet and pull out the rear door harness connector from inside the center pillar.

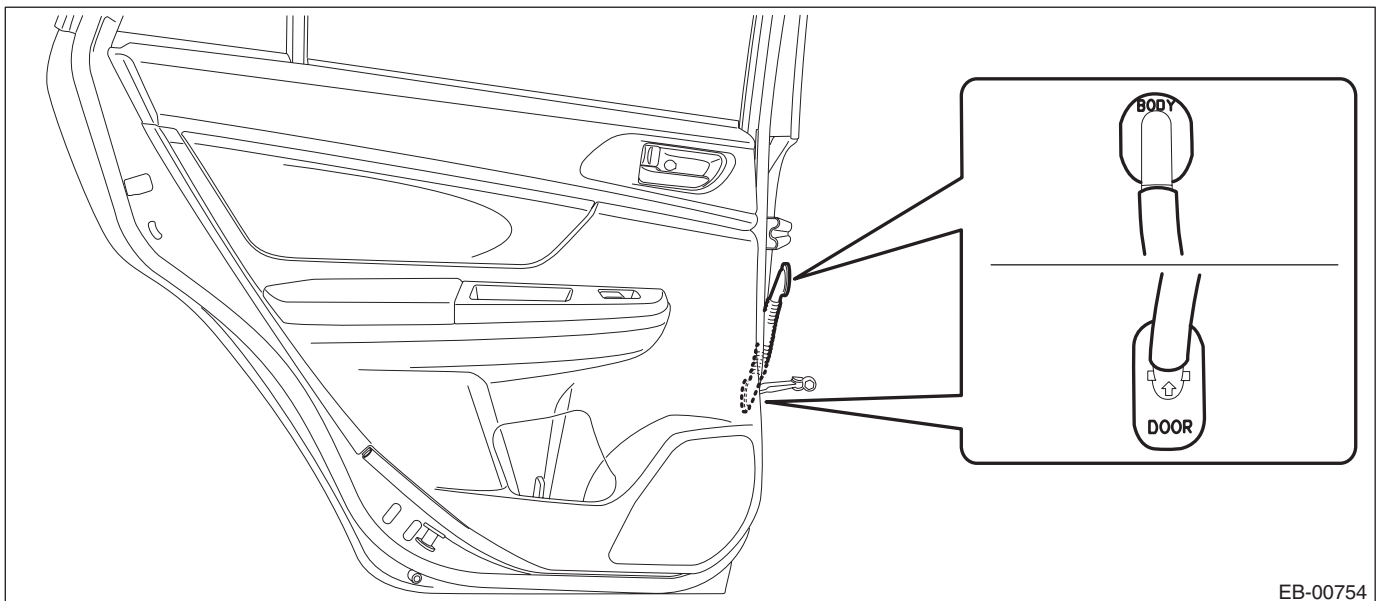

## Rear Door

### EXTERIOR BODY PANELS

---

- (2) Disconnect the rear door harness connectors.

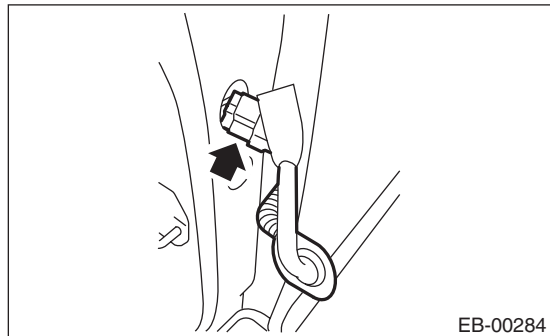

- 13) Before removing the panel assembly - rear door, make the following preparations.

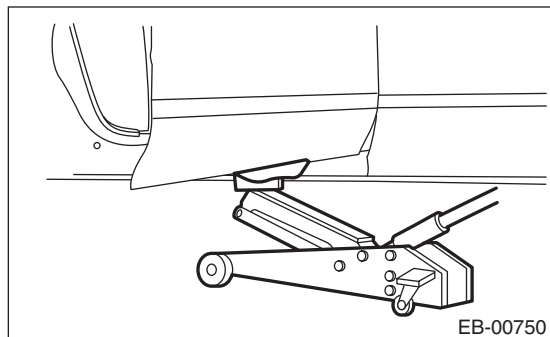

- (1) Put a wooden block on a floor jack and place the jack under the panel assembly - rear door.  
(2) Support the panel assembly - rear door with the jack to protect it from damage.

#### **CAUTION:**

**Do not excessively lift the panel assembly - rear door with the floor jack. The door hinges may be damaged.**

- 14) Remove the door-side bolts for the upper hinge - rear door and the lower hinge - rear door to remove the panel assembly - rear door.

#### **CAUTION:**

**The panel assembly - rear door is heavy. When removing and installing it, always work in a team of two or more persons.**

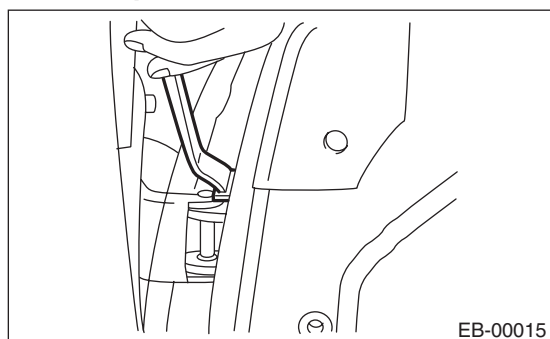

- 15) Remove the door hinge from vehicle. <Ref. to EB-36, REAR DOOR HINGE, REMOVAL, Rear Door.>

## **2. REAR DOOR HINGE**

- 1) Open the panel assembly - front door, and remove the bolts of the upper hinge - rear door or the lower hinge - rear door.

#### **CAUTION:**

- **Do not remove the upper hinge - front door and the lower hinge - front door at the same time.**
- **Removal and installation of the panel assembly - rear door must be performed with the door closed.**

- 2) Remove the rear door hinge from vehicle.

## B: INSTALLATION

### 1. REAR DOOR PANEL

1) Put a wooden block on a jack and place the panel assembly - rear door on it.

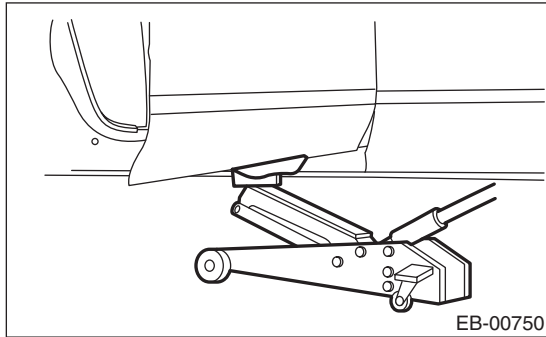

2) Apply grease to the moving part of door hinges.

3) Adjust the height by the jack, and temporarily install the panel assembly - rear door to the upper hinge - rear door and the lower hinge - rear door.

#### NOTE:

- When installing the panel assembly - rear door, make sure that a uniform clearance is created around the panel.
  - Perform installation while paying attention to the assembly direction of the grommet.
- 4) Adjust the clearance around the panel assembly - rear door. <Ref. to EB-38, ADJUSTMENT, Rear Door.>  
 5) Tighten the bolts and nuts of the door hinge and the checker assembly - rear door.

#### **Tightening torque:**

**Refer to "COMPONENT" of "General Description". <Ref. to EB-5, REAR DOOR, COMPONENT, General Description.>**

6) Install door internal parts in the reverse order of removal.

7) Connect the door harness connector, and install the trim panel - center pillar LWR.

### 2. REAR DOOR HINGE

1) Apply grease to the moving part of door hinges.

2) Adjust the clearance around the panel assembly - rear door. <Ref. to EB-38, ADJUSTMENT, Rear Door.>

3) Tighten the door hinge bolts.

#### **Tightening torque:**

**Refer to "COMPONENT" of "General Description". <Ref. to EB-5, REAR DOOR, COMPONENT, General Description.>**

# Rear Door

## EXTERIOR BODY PANELS

### C: ADJUSTMENT

Adjust the clearance around the panel assembly - rear door as follows.

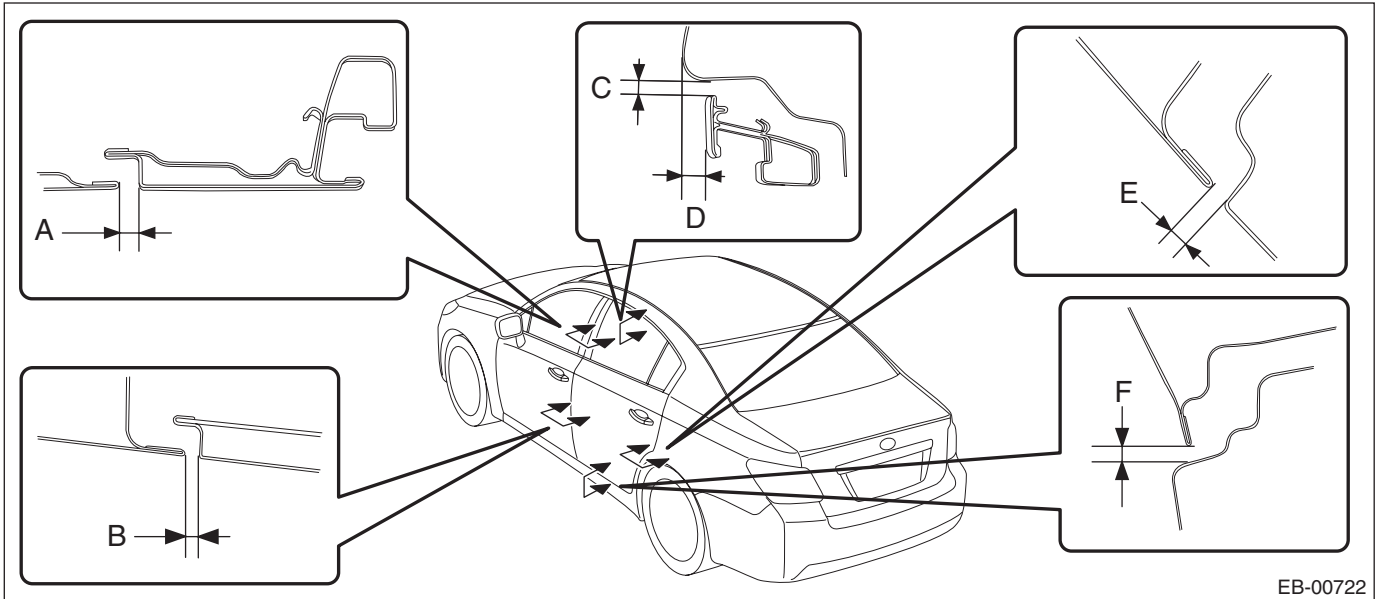

EB-00722

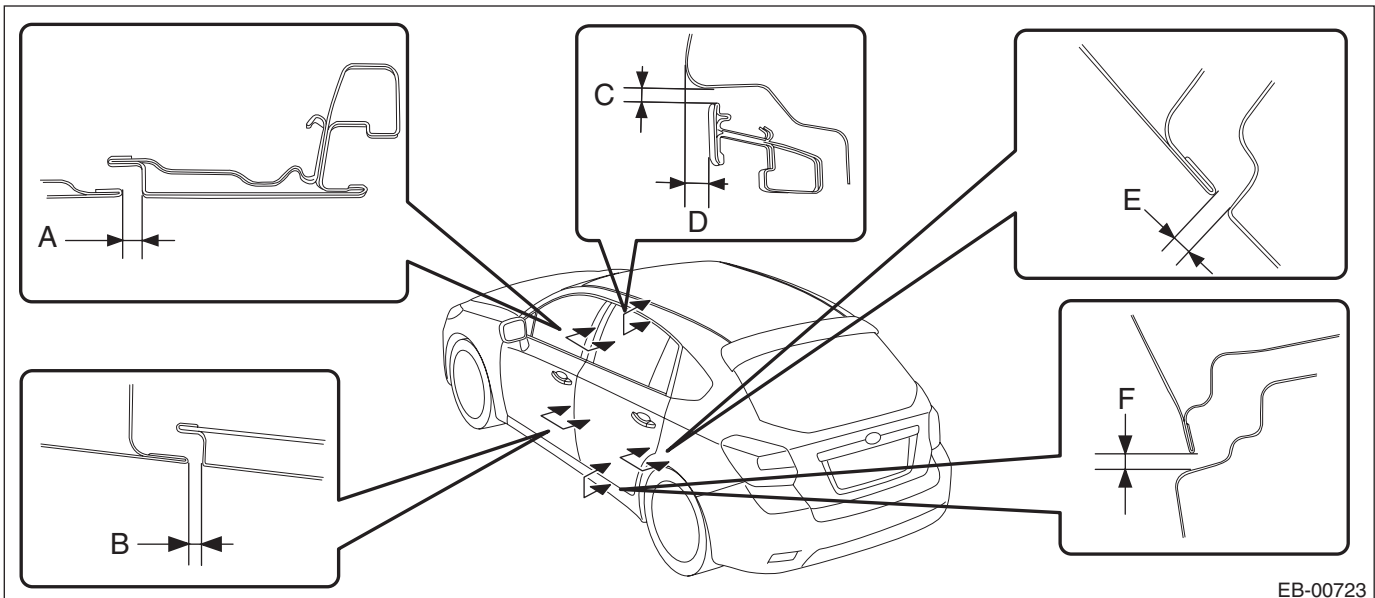

EB-00723

Part		Standard
A	Front door sash to Rear door sash	5.5+1.5, -1.0 mm (0.22+0.06, -0.04 in)
B	Panel assembly - front door to Panel assembly - rear door	4.5±1.0 mm (0.18±0.04 in)
C	Roof panel to Rear door sash	5.1+1.5, -1.0 mm (0.20+0.06, -0.04 in)
D	Surface level gap between roof panel and rear door sash	6.6±1.5 mm (0.26±0.06 in)
E	Panel assembly - rear door to Rear quarter panel	4.1±1.0 mm (0.16±0.04 in)
F	Panel assembly - rear door to Side sill spoiler	6.0±1.5 mm (0.24±0.06 in)

- 1) Adjust the vertical and horizontal positions of the panel assembly - rear door.

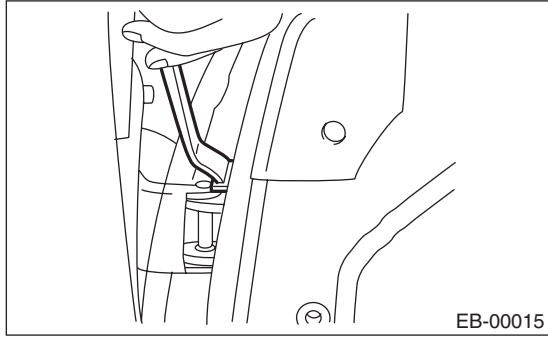

- (1) Loosen the body side bolts of the upper hinge - rear door and the lower hinge - rear door.
  - (2) Adjust the vertical and horizontal clearance of the panel assembly - rear door.
- 2) Adjust the surface level gap between the panel assembly - rear door and the body.

**CAUTION:**

**Do not use an impact wrench. Welding area on the striker nut plate is easily broken.**

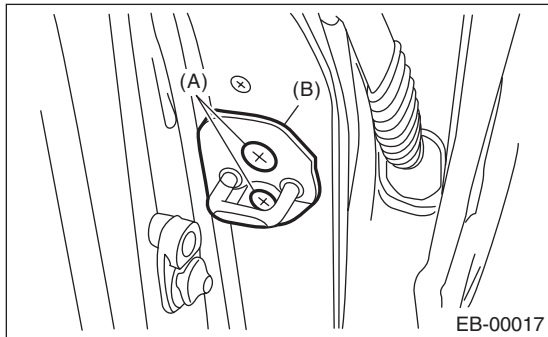

- (1) Loosen the screws (A).
- (2) Tap the striker - rear door (B) using a plastic hammer to adjust the surface level gap between the rear end of the panel assembly - rear door and the rear quarter.