

## 10.Rear Gate

### A: REMOVAL

#### CAUTION:

The panel - rear gate is heavy. When removing and installing it, always work in a team of two or more persons.

#### 1. REAR GATE PANEL

- 1) Disconnect the ground cable from battery.
- 2) Remove the following parts. <Ref. to EI-152, REMOVAL, Rear Gate Garnish.>
  - Trim panel - rear gate
  - Arm assembly - rear wiper and motor assembly - rear wiper
  - Garnish assembly - rear gate
- 3) Remove the light assembly - high-mounted and the nozzle - rear washer. <Ref. to WW-44, REMOVAL, Rear Washer.>
- 4) Remove the rear gate latch and actuator - rear gate. <Ref. to SL-48, REMOVAL, Rear Gate Latch and Actuator Assembly.>
- 5) Remove the clips, and remove the drip - rear gate.

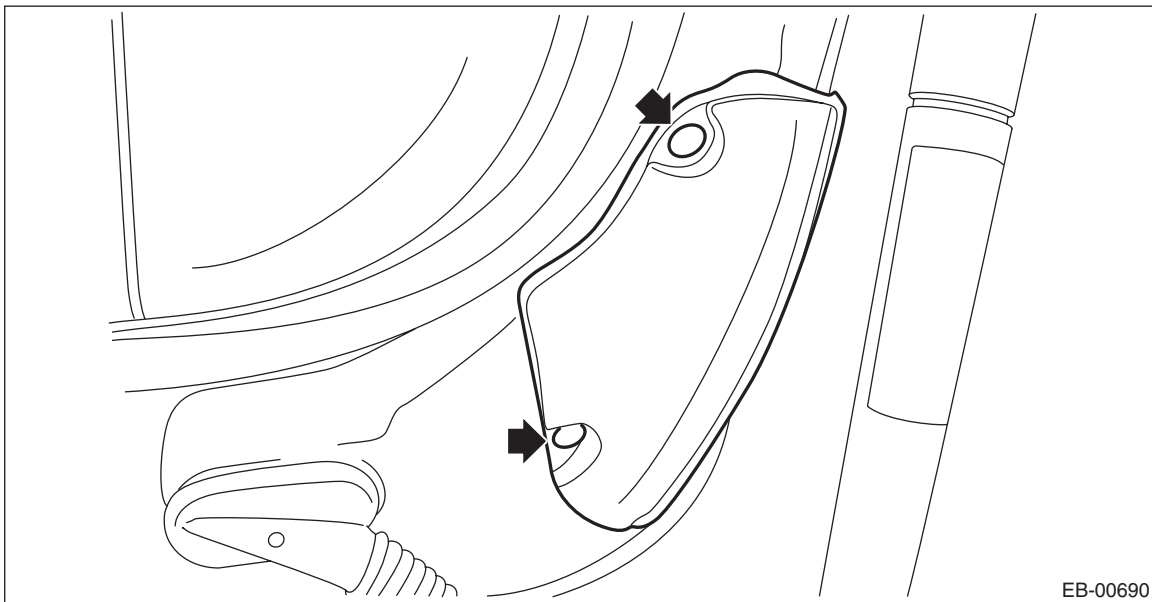

## Rear Gate

### EXTERIOR BODY PANELS

6) Remove the trim panel - rear gate UPR.

(1) Remove the claws on the trim edge.

(2) Release the claws in the center of trim, and remove the trim panel - rear gate UPR.

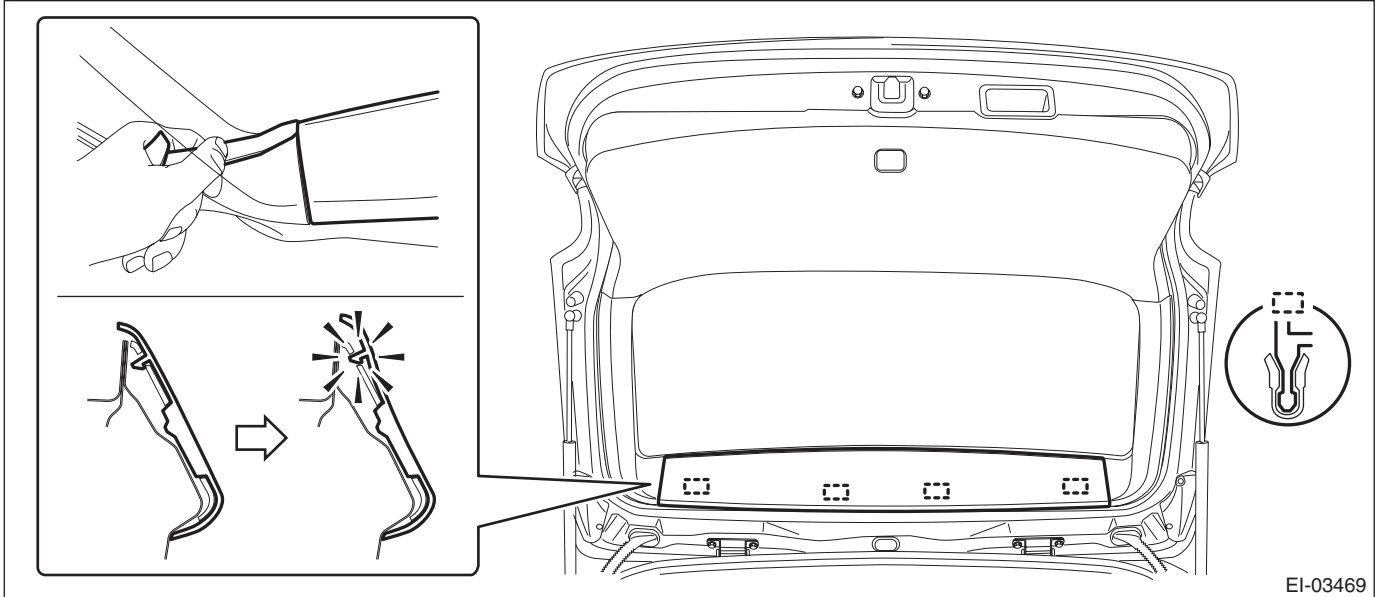

7) Remove the rubber duct (A).

(1) Pull out the claw while pushing it using a flat tip screwdriver (B) or similar tools.

(2) Remove the rubber duct (A) connection.

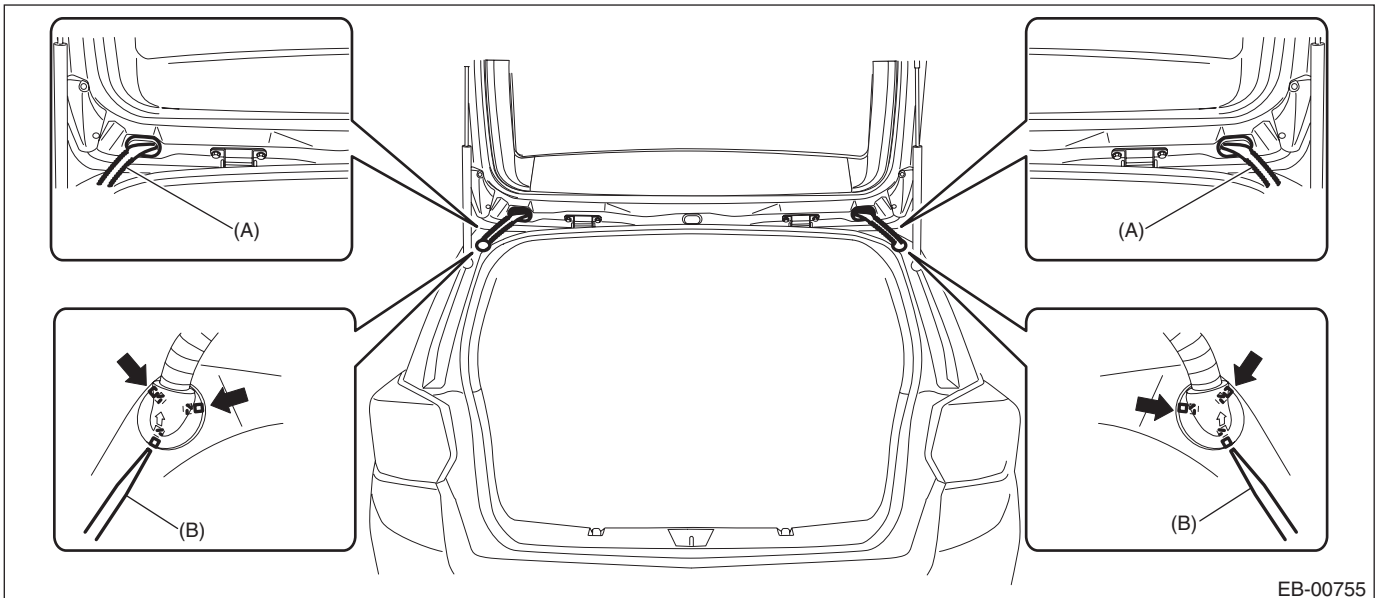

8) Pull out the harness and the hose assembly - rear washer from the panel - rear gate.

9) Remove harness clip of each harness from the panel - rear gate.

10) Before removing the stay assembly - rear gate, prevent the panel - rear gate from closing by using a prop or the like.

**CAUTION:**

**If the prop comes off, operators may get injured and vehicle may get damaged. Make sure to support the panel - rear gate with secure material to prevent injury or damage.**

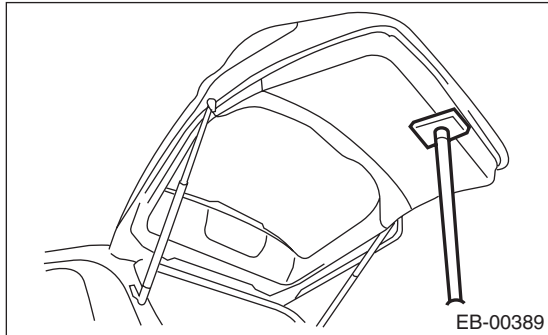

11) Remove the mounting bolts from the stay assembly - rear gate.

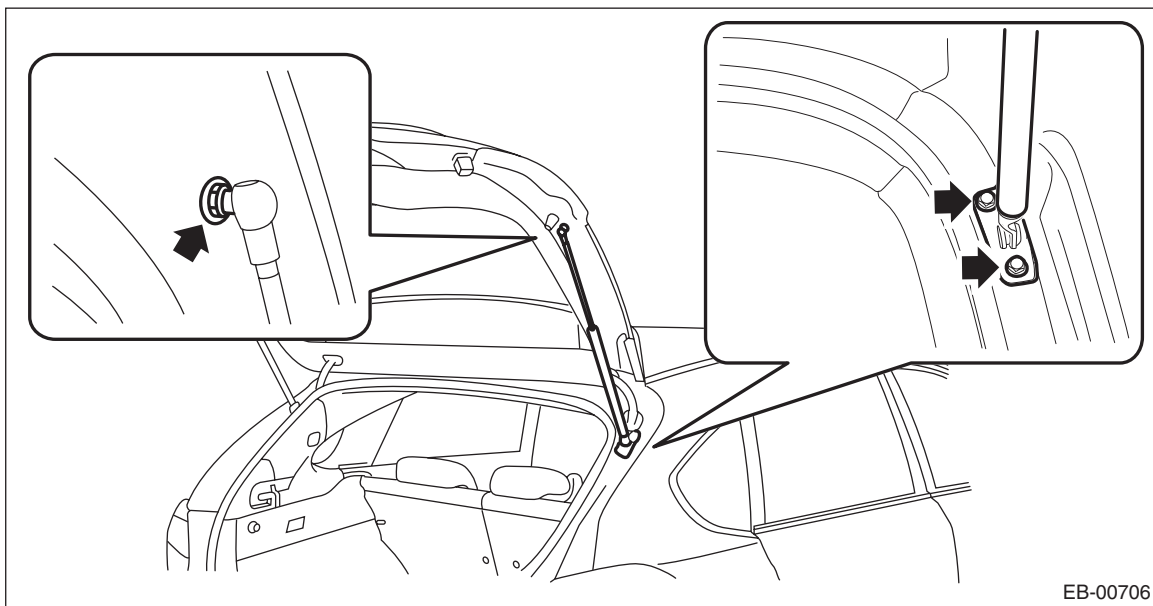

## Rear Gate

### EXTERIOR BODY PANELS

---

12) Remove the bolts of the hinge - rear gate, and remove the panel - rear gate.

**CAUTION:**

**The panel - rear gate is heavy. When removing and installing it, always work in a team of two or more persons.**

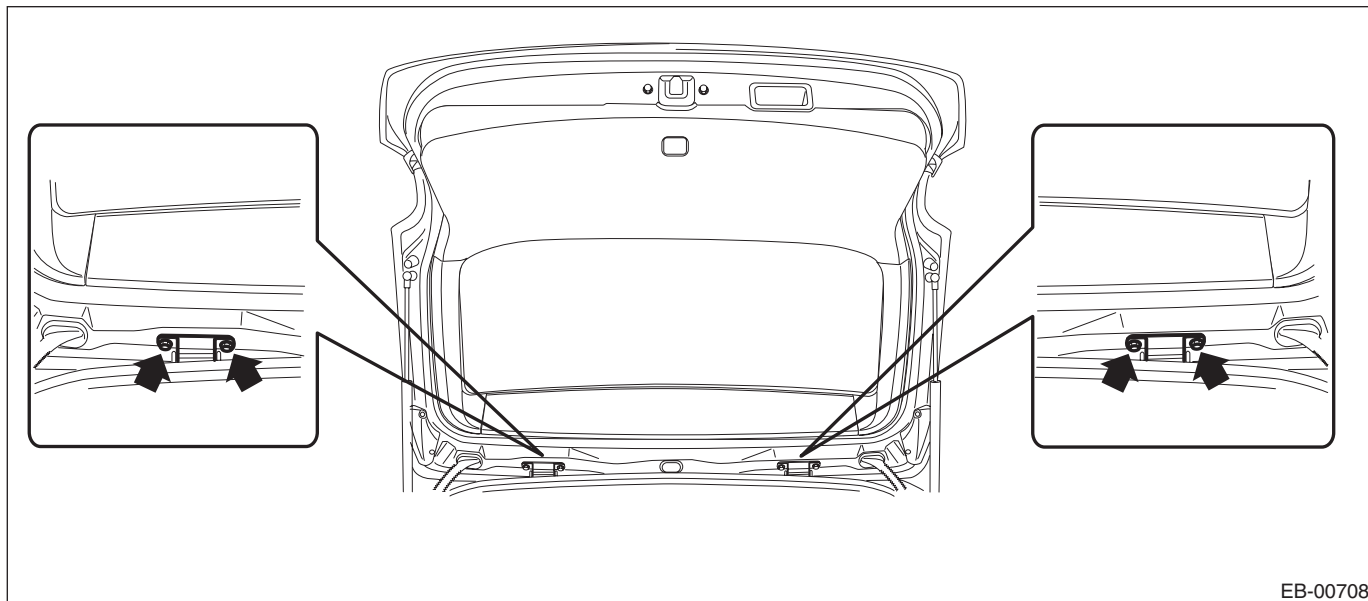

EB-00708

13) Remove the hinge - rear gate from the vehicle.

## 2. REAR GATE DAMPER STAY

### CAUTION:

- Do not damage piston rods and oil seals.
- Never disassemble cylinders: They contain gas.
- The panel - rear gate is heavy. When removing and installing it, always work in a team of two or more persons.

1) Before removing the stay assembly - rear gate, prevent the panel - rear gate from closing by using a prop or the like.

### CAUTION:

If the prop comes off, operators may get injured and vehicle may get damaged. Make sure to support the panel - rear gate with secure material to prevent injury or damage.

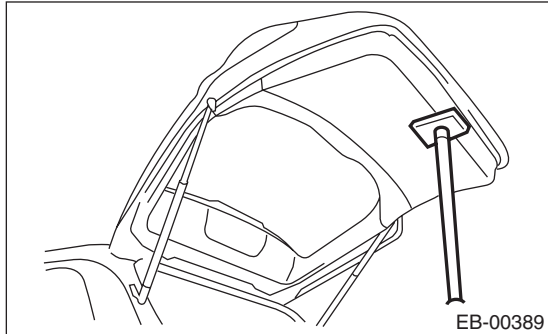

2) Remove the mounting bolts and remove the stay assembly - rear gate.

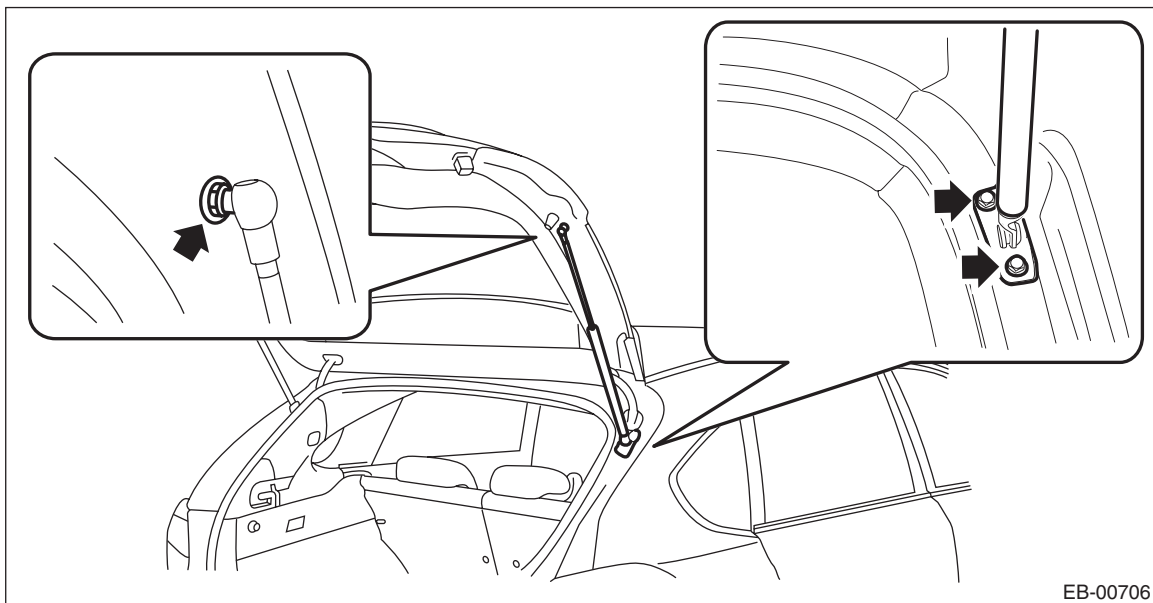

# Rear Gate

## EXTERIOR BODY PANELS

---

### B: INSTALLATION

#### 1. REAR GATE PANEL

##### CAUTION:

The panel - rear gate is heavy. When removing and installing it, always work in a team of two or more persons.

- 1) Install the hinge - rear gate to the vehicle body.
- 2) Temporarily install the panel - rear gate to the hinge - rear gate.

##### NOTE:

When installing, make sure that a uniform clearance is created around the panel - rear gate.

- 3) Adjust the clearance around the panel - rear gate. <Ref. to EB-63, ADJUSTMENT, Rear Gate.>
- 4) Tighten the bolts of the hinge - rear gate.

##### **Tightening torque:**

**25 N·m (2.55 kgf-m, 18.4 ft-lb)**

- 5) Install each part in the reverse order of removal.

##### **Tightening torque:**

**Rear gate parts:** <Ref. to EB-7, REAR GATE, COMPONENT, General Description.>

**Garnish assembly - rear gate:** 4.5 N·m (0.46 kgf-m, 3.3 ft-lb)

**Arm assembly - rear wiper and motor assembly - rear wiper:** <Ref. to WW-3, REAR WIPER, COMPONENT, General Description.>

#### 2. REAR GATE DAMPER STAY

##### CAUTION:

The panel - rear gate is heavy. When removing and installing it, always work in a team of two or more persons.

- 1) Prevent the panel - rear gate from closing using prop or the like.

##### CAUTION:

If the prop comes off, operators may get injured and vehicle may get damaged. Make sure to support the panel - rear gate with secure material to prevent injury or damage.

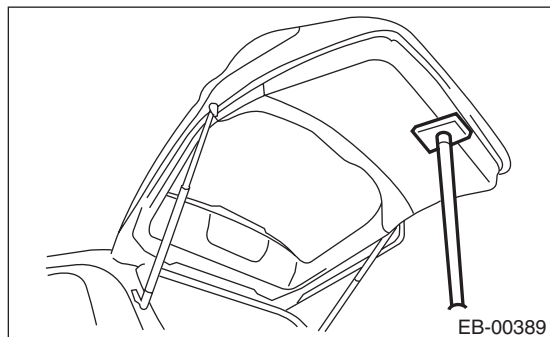

- 2) Install each part in the reverse order of removal.

##### **Tightening torque:**

**Refer to "COMPONENT" of "General Description".** <Ref. to EB-7, REAR GATE, COMPONENT, General Description.>

## C: ADJUSTMENT

Adjust the clearance around the panel - rear gate as follows.

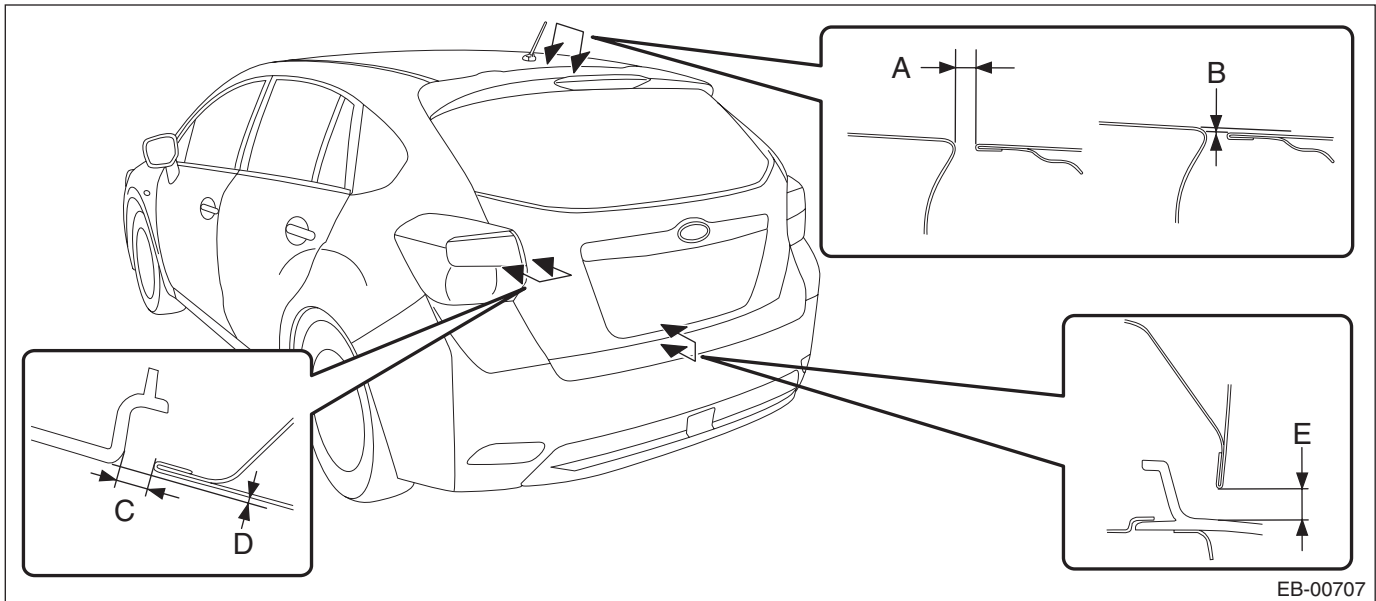

Part		Standard
A	Panel - rear gate to Roof panel	6.0+1.0, -0.5 mm (0.24+0.04, -0.02 in)
B	Surface level gap: Panel - rear gate to Roof panel	1.0±1.0 mm (0.04±0.04 in)
C	Panel - rear gate to Light assembly - rear combination	6.0±1.0 mm (0.24±0.04 in)
D	Surface level gap: Panel - rear gate to Light assembly - rear combination	1.0±1.0 mm (0.04±0.04 in)
E	Panel - rear gate to Bumper face - rear	8.0±1.5 mm (0.31±0.06 in)

1) Adjust the vertical and horizontal positions of the panel - rear gate.

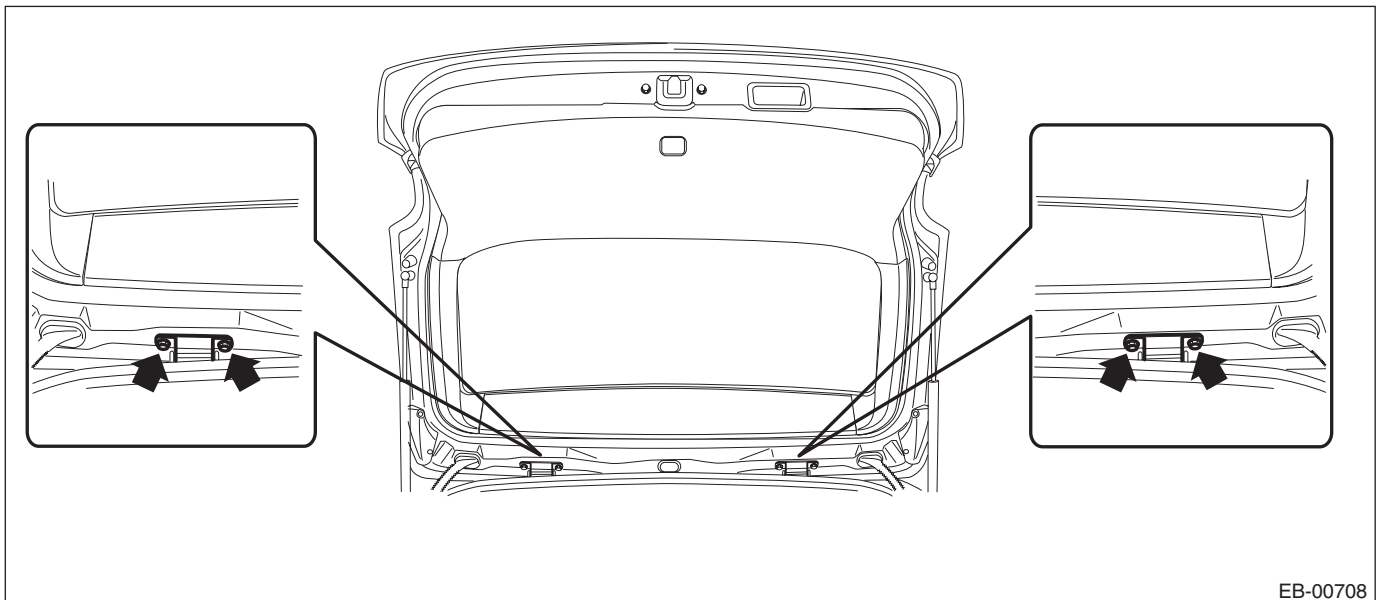

- (1) Loosen the mounting bolts of the hinge - rear gate.
- (2) Adjust the vertical and horizontal clearance of the panel - rear gate.

**Tightening torque:**  
**25 N·m (2.55 kgf·m, 18.4 ft·lb)**

## Rear Gate

### EXTERIOR BODY PANELS

---

2) Adjust the surface level gap between the panel - rear gate and the body.

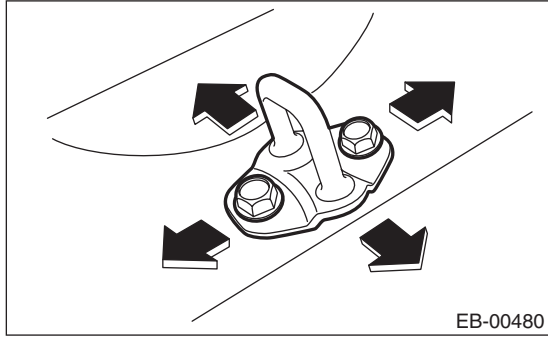

(1) Remove the trim panel - rear skirt.

(2) Loosen the bolt.

(3) Tap the striker - rear gate using a plastic hammer to adjust the surface level gap between the panel - rear gate and the body.

#### ***Tightening torque:***

***25 N·m (2.55 kgf·m, 18.4 ft·lb)***



**D: DISPOSAL****1. REAR GATE DAMPER STAY****CAUTION:**

Gas is colorless, odorless, and harmless. However, gas pressure may spray cutting powder or oil. Be sure to wear dust-resistant goggles.

1) Cover with a vinyl sack as shown in the figure.

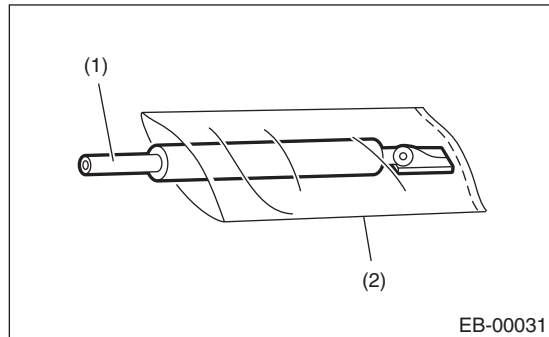

(1) Stay ASSY - rear gate

(2) Vinyl sack

**NOTE:**

Prevent the vinyl sack from being caught by drill cutting edge.

2) Lift the body side slightly with piston rods fully extended, and secure the body side with vise.

Drill a hole of 2 to 3 mm (0.08 to 0.12 in) diameter at a point 6 to 196 mm (0.24 to 7.72 in) from the body side, and bleed the gas in the stay assembly - rear gate completely.

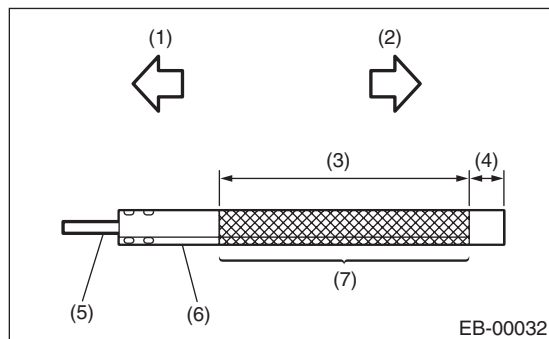

(1) Door side

(2) Body side

(3) 196 mm (7.72 in)

(4) 6 mm (0.24 in)

(5) Piston rod

(6) Cylinder

(7) Portion to be drilled