

11. Diagnostic Procedure with Diagnostic Trouble Code (DTC)

A: DTC U1201 CAN-HS COUNTER ABNORMAL

DTC DETECTING CONDITION:

Communication is unstable because of high speed CAN communication error.

TROUBLE SYMPTOM:

- Display of combination meter indicates faulty.
- Control faulty may occur due to CAN communication error.

WIRING DIAGRAM:

CAN communication system <Ref. to WI-46, WIRING DIAGRAM, CAN Communication System.>

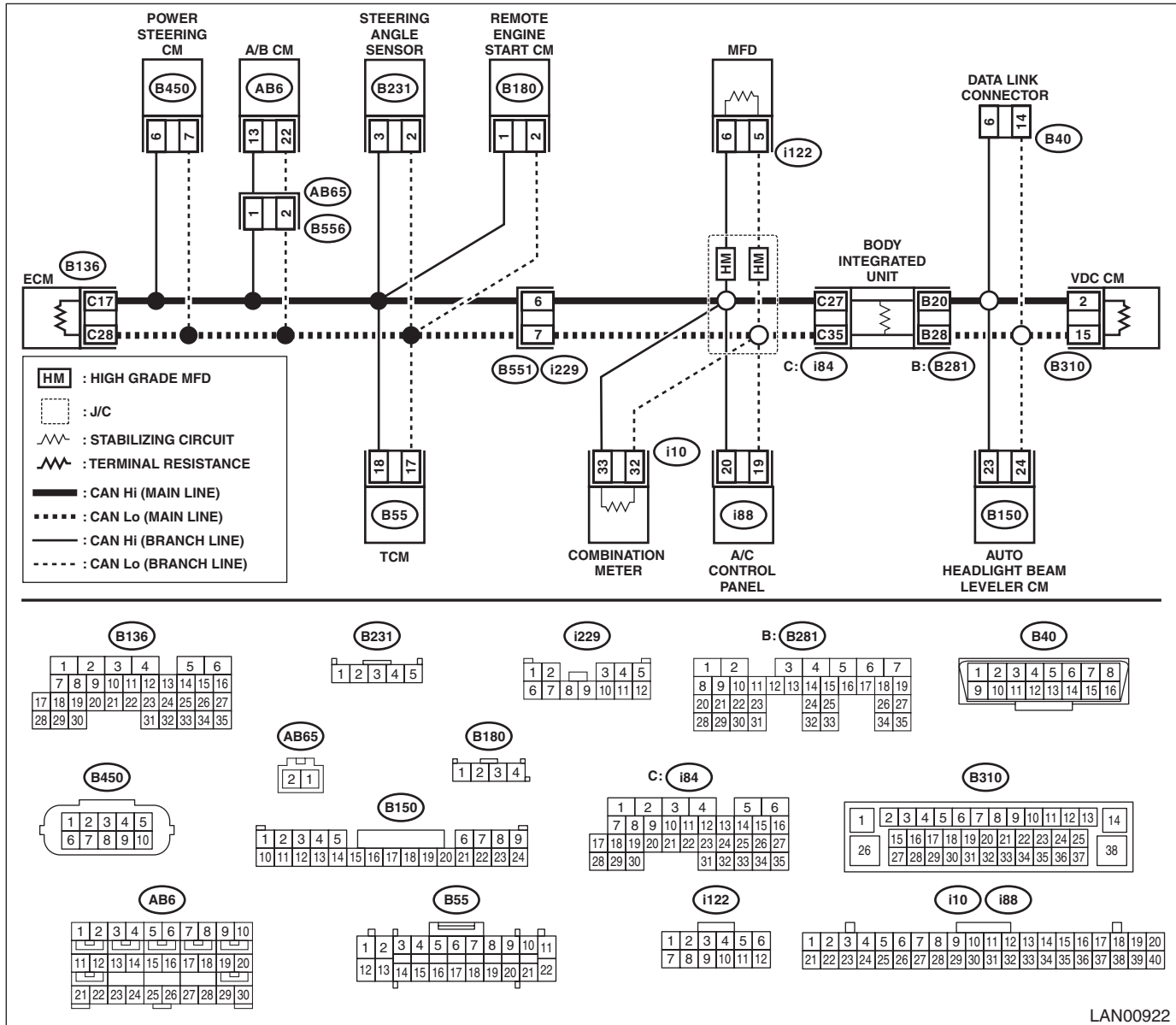

LAN00922

Diagnostic Procedure with Diagnostic Trouble Code (DTC)

LAN SYSTEM (DIAGNOSTICS)

Step	Check	Yes	No
1 CHECK CAN COMMUNICATION CIRCUIT. Check CAN communication circuit. <Ref. to LAN(diag)-24, PROCEDURE, CAN Communication Circuit Check.>	Is CAN communication circuit faulty?	Repair the faulty portion, following the diagnosis procedure.	Go to step 2.
2 CHECK DTC. 1) Start the engine. 2) Using the Subaru Select Monitor, read DTC of CAN system.	Is U0073 a current malfunction?	Perform the diagnosis of U0073. <Ref. to LAN(diag)-87, DTC U0073 CONTROL MODULE COMMUNICATION BUS "A" OFF, Diagnostic Procedure with Diagnostic Trouble Code (DTC).>	Go to step 3.
3 CHECK DTC. Check the displayed DTC.	Is U1201 a current malfunction?	Go to step 4.	It is possible that temporary poor communication occurs. Perform the clear memory.
4 CHECK DTC. 1) Turn the ignition switch to ON. 2) Using the Subaru Select Monitor, read DTC of CAN system.	Is U1201 a current malfunction?	Go to step 5.	It is possible that temporary poor communication occurs. Perform the clear memory.
5 CHECK CONTROL MODULE. 1) Turn the ignition switch to OFF. 2) Disconnect the control modules other than body integrated unit in order. NOTE: When disconnecting ECM or VDC CM, connect resistance of 120 Ω between CAN Hi and CAN Lo as an alternative of end resistance. 3) Turn the ignition switch to ON. 4) Using the Subaru Select Monitor, read DTC of CAN system.	Is there any control module that U1201 is not detected as current malfunction?	Replace the control module.	Repeat 1) to 4) in step 5 until U1201 is not detected.

Diagnostic Procedure with Diagnostic Trouble Code (DTC)

LAN SYSTEM (DIAGNOSTICS)

B: DTC U0073 CONTROL MODULE COMMUNICATION BUS "A" OFF

DTC DETECTING CONDITION:

Integrated unit communication is shut down because of high speed CAN error.

TROUBLE SYMPTOM:

CAN communication is not normal.

WIRING DIAGRAM:

CAN communication system <Ref. to WI-46, WIRING DIAGRAM, CAN Communication System.>

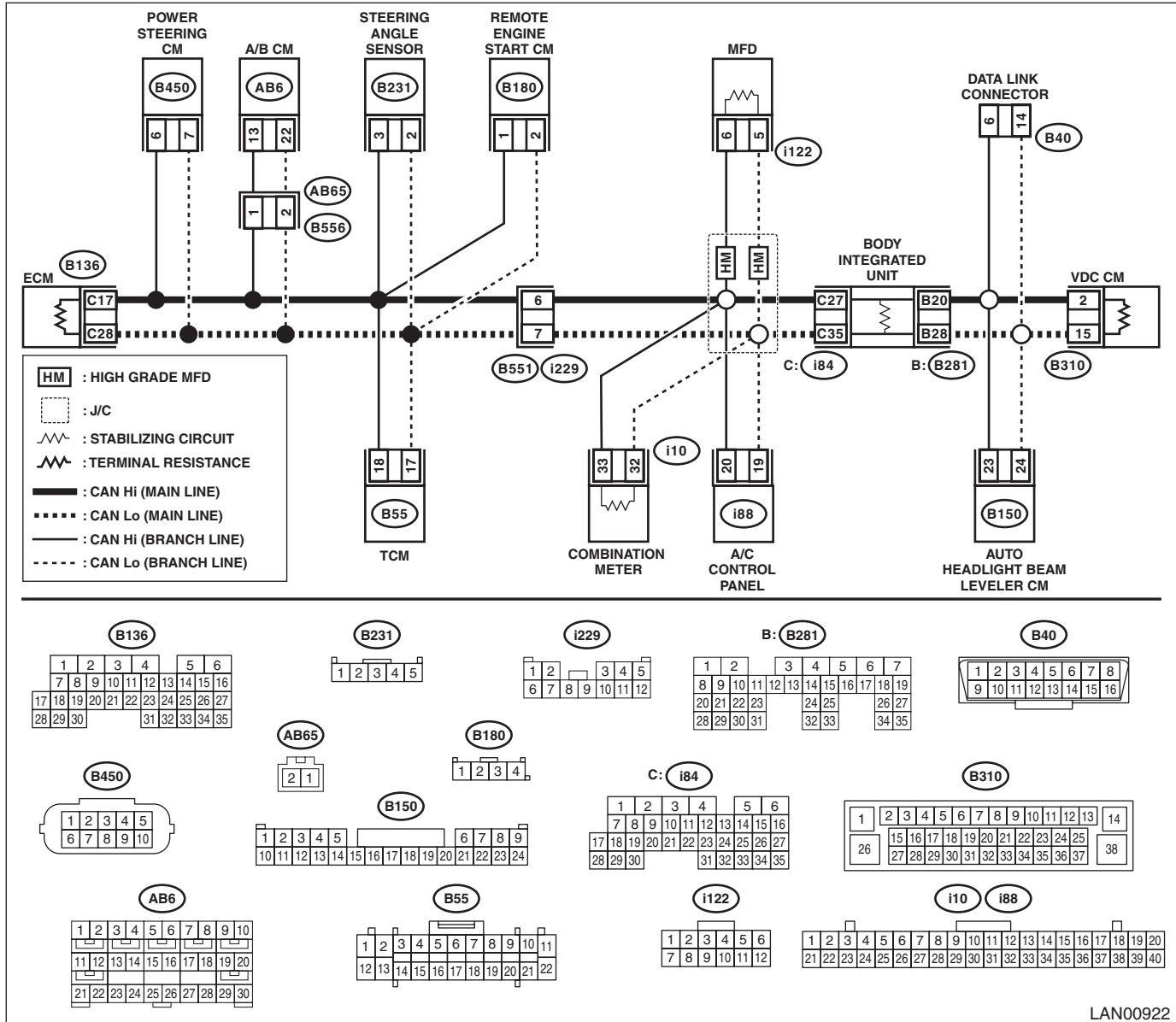

Step	Check	Yes	No
1	CHECK DTC. 1) Start the engine. 2) Using the Subaru Select Monitor, read DTC of CAN system.	Go to step 2.	It may be a temporary poor contact. Perform the clear memory.
2	CHECK CAN COMMUNICATION CIRCUIT. Check CAN communication circuit. <Ref. to LAN(diag)-24, PROCEDURE, CAN Communication Circuit Check.>	Repair the faulty portion, following the diagnosis procedure.	Go to step 3.

Diagnostic Procedure with Diagnostic Trouble Code (DTC)

LAN SYSTEM (DIAGNOSTICS)

Step	Check	Yes	No
3 CHECK DTC. 1) Perform the inspection using the DTC check sheet. <Ref. to LAN(diag)-52, CHECK USING THE DTC CHECK SHEET, LIST, List of Diagnostic Trouble Code (DTC).> 2) Using the Subaru Select Monitor, read DTC of CAN system.	Is U0073 a current malfunction?	Go to step 4.	System is normal.
4 CHECK CONTROL MODULE. 1) Turn the ignition switch to OFF. 2) Disconnect the control modules other than body integrated unit in order. NOTE: When disconnecting ECM or VDC CM, connect resistance of 120 Ω between CAN Hi and CAN Lo as an alternative of end resistance. 3) Turn the ignition switch to ON. 4) Using the Subaru Select Monitor, read DTC of CAN system.	Is there any control module that U0073 is not detected as current malfunction?	Replace the control module.	Repeat 1) to 4) in step 3 until U0073 is not detected.

Diagnostic Procedure with Diagnostic Trouble Code (DTC)

LAN SYSTEM (DIAGNOSTICS)

C: DTC U0401 INVALID DATA RECEIVED FROM ECM/PCM "A"

DTC DETECTING CONDITION:

Defective data from ECM.

TROUBLE SYMPTOM:

Defective data on CAN communication occurs.

WIRING DIAGRAM:

CAN communication system <Ref. to WI-46, WIRING DIAGRAM, CAN Communication System.>

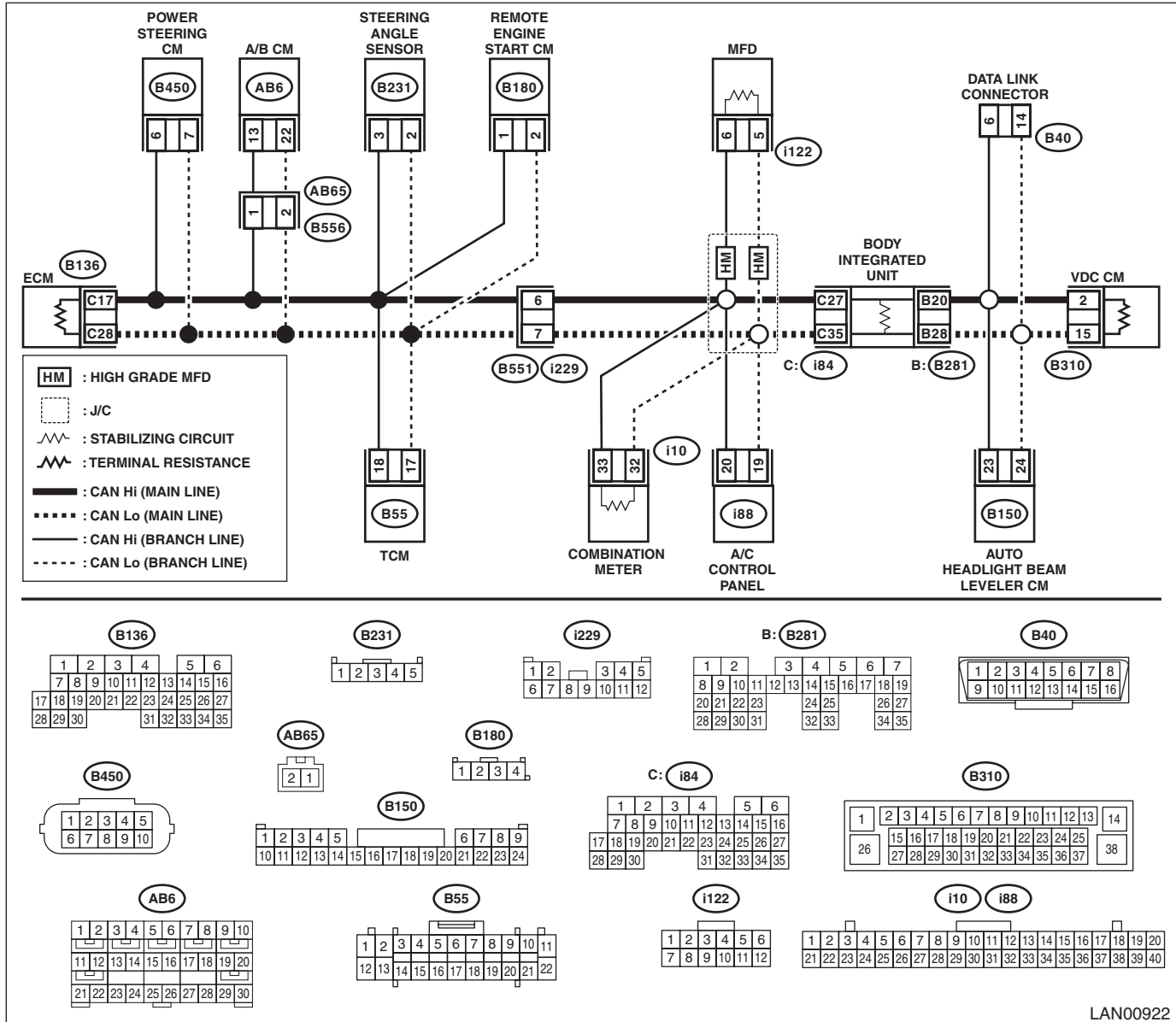

LAN00922

Step	Check	Yes	No
1	CHECK DTC. Check the displayed DTC.	Are DTCs other than U*** displayed?	Perform the diagnosis according to DTC. Go to step 2.
2	CHECK DTC. Check the displayed DTC.	Is DTC for the buss off or the data no-receive displayed?	Perform the diagnosis according to DTC. Go to step 3.
3	CHECK DTC. Check the displayed DTC.	Is U0401 a current malfunction?	Go to step 4. Go to step 8.

Diagnostic Procedure with Diagnostic Trouble Code (DTC)

LAN SYSTEM (DIAGNOSTICS)

Step	Check	Yes	No
4 CHECK DTC. 1) Turn the ignition switch to OFF. 2) Disconnect the ECM connector. 3) Connect the disconnected connectors. 4) Read the DTC using Subaru Select Monitor.	Is U0401 a current malfunction?	Go to step 5.	Go to step 8.
5 CHECK DTC. Using the Subaru Select Monitor, read DTC of all the systems.	Is the engine data abnormal detected in several modules?	Replace the ECM. <Ref. to FU(H4DO)-102, Engine Control Module (ECM).>	Go to step 6.
6 REPLACE MODULE. 1) Replace the ECM. 2) Read the DTC using Subaru Select Monitor.	Is U0401 a current malfunction?	Go to step 7.	System is normal.
7 CHECK MODULE. 1) Reinstall the ECM. 2) Replace the module that the DTC has been detected. 3) Read the DTC using Subaru Select Monitor.	Is U0401 a current malfunction?	Replace the ECM. <Ref. to FU(H4DO)-102, Engine Control Module (ECM).>	System is normal.
8 CHECK HARNESS. 1) Shake the harness, and check for poor contact. 2) Using the Subaru Select Monitor, read DTC of CAN system.	Is U0401 a current malfunction?	Repair the poor contact of harness, or replace the harness.	Go to step 9.
9 CHECK CONNECTOR. Check the connector used for high speed CAN for poor contact.	Is there poor contact of connector?	Repair the connector that has poor contact, or replace harness.	It is possible that temporary poor communication occurs. Delete the DTC.

Diagnostic Procedure with Diagnostic Trouble Code (DTC)

LAN SYSTEM (DIAGNOSTICS)

D: DTC U0402 INVALID DATA RECEIVED FROM TCM

DTC DETECTING CONDITION:

Received error data from TCM.

TROUBLE SYMPTOM:

SPORT indicator light blinks.

WIRING DIAGRAM:

CAN communication system <Ref. to WI-46, WIRING DIAGRAM, CAN Communication System.>

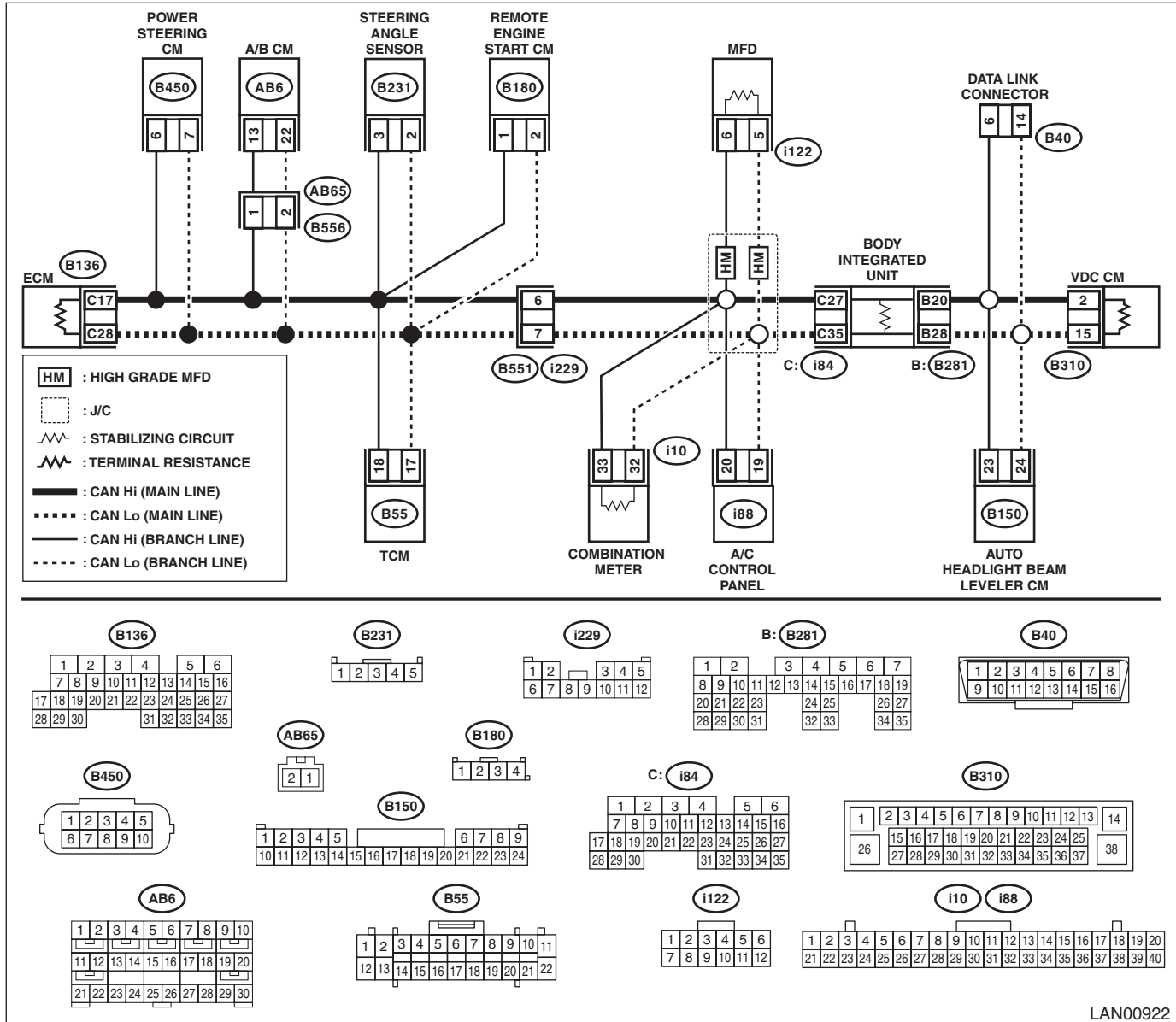

Step	Check	Yes	No
1	CHECK DTC. Check the displayed DTC.	Are DTCs other than U*** displayed?	Perform the diagnosis according to DTC. Go to step 2.
2	CHECK DTC. Check the displayed DTC.	Is DTC for the buss off or the data no-receive displayed?	Perform the diagnosis according to DTC. Go to step 3.
3	CHECK DTC. Check the displayed DTC.	Is U0402 a current malfunction?	Go to step 4. Go to step 8.

Diagnostic Procedure with Diagnostic Trouble Code (DTC)

LAN SYSTEM (DIAGNOSTICS)

Step	Check	Yes	No
4 CHECK DTC. 1) Turn the ignition switch to OFF. 2) Disconnect the TCM connector. 3) Connect the disconnected connectors. 4) Read the DTC using Subaru Select Monitor.	Is U0402 a current malfunction?	Go to step 5.	Go to step 8.
5 CHECK DTC. Using the Subaru Select Monitor, read DTC of all the systems.	Is the transmission data abnormal detected in several modules?	Replace the TCM. <Ref. to CVT-136, Transmission Control Module (TCM).>	Go to step 6.
6 REPLACE MODULE. 1) Replace the TCM. 2) Read the DTC using Subaru Select Monitor.	Is U0402 a current malfunction?	Go to step 7.	System is normal.
7 CHECK MODULE. 1) Reinstall the TCM. 2) Replace the module that the DTC has been detected. 3) Read the DTC using Subaru Select Monitor.	Is U0402 a current malfunction?	Replace the TCM. <Ref. to CVT-136, Transmission Control Module (TCM).>	System is normal.
8 CHECK HARNESS. 1) Shake the harness, and check for poor contact. 2) Using the Subaru Select Monitor, read DTC of CAN system.	Is U0402 a current malfunction?	Repair the poor contact of harness, or replace the harness.	Go to step 9.
9 CHECK CONNECTOR. Check the connector used for high speed CAN for poor contact.	Is there poor contact of connector?	Repair the connector that has poor contact, or replace harness.	It is possible that temporary poor communication occurs. Delete the DTC.

Diagnostic Procedure with Diagnostic Trouble Code (DTC)

LAN SYSTEM (DIAGNOSTICS)

E: DTC U0416 INVALID DATA RECEIVED FROM VEHICLE DYNAMICS CONTROL MODULE

DTC DETECTING CONDITION:

Data from VDCCM is faulty.

TROUBLE SYMPTOM:

ABS warning light and VDC warning light illuminate.

WIRING DIAGRAM:

CAN communication system <Ref. to WI-46, WIRING DIAGRAM, CAN Communication System.>

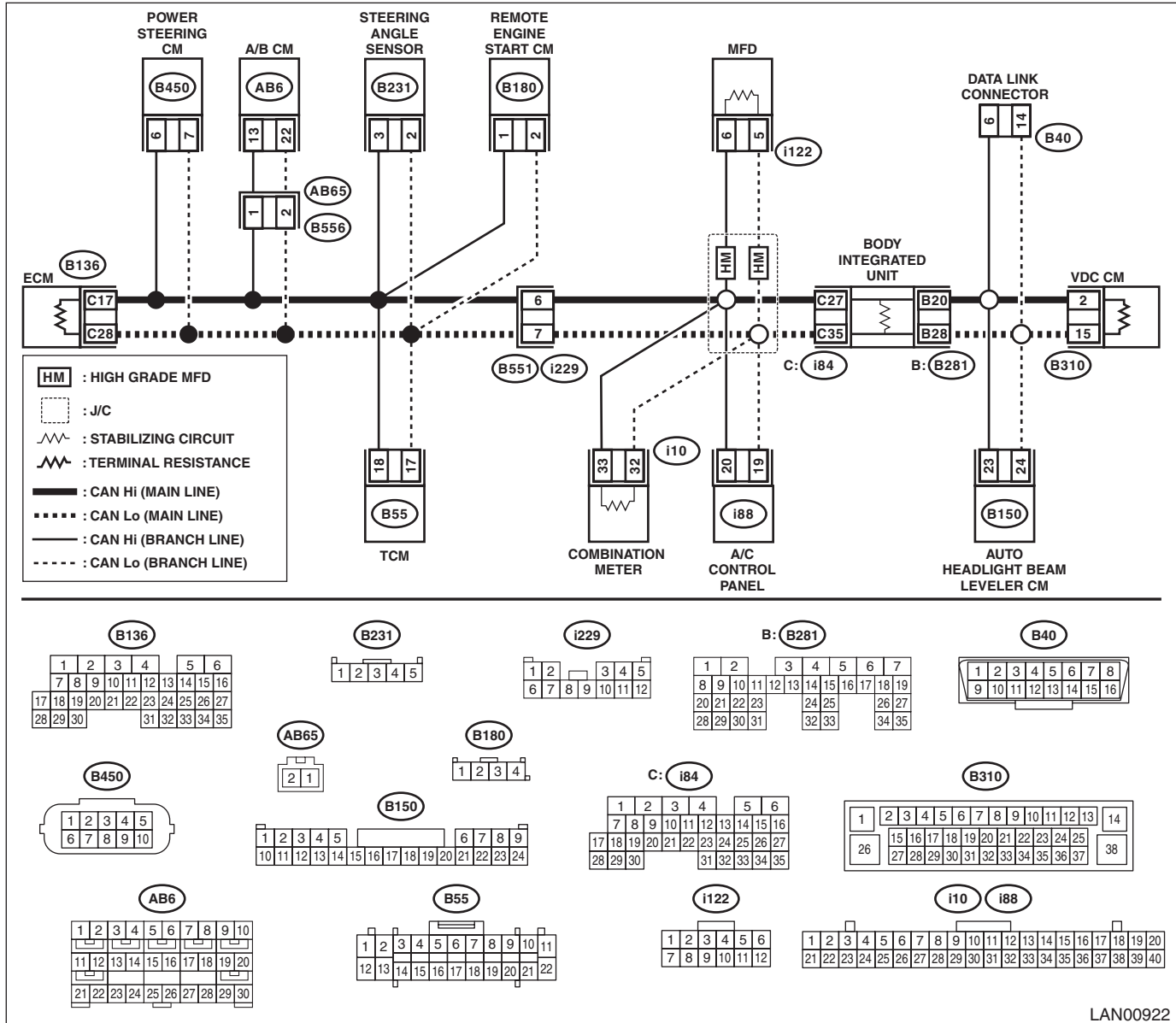

LAN00922

Step	Check	Yes	No
1	CHECK DTC. Check the displayed DTC.	Are DTCs other than U*** displayed?	Perform the diagnosis according to DTC. Go to step 2.
2	CHECK DTC. Check the displayed DTC.	Is DTC for the buss off or the data no-receive displayed?	Perform the diagnosis according to DTC. Go to step 3.
3	CHECK DTC. Check the displayed DTC.	Is U0416 a current malfunction?	Go to step 4. Go to step 8.

Diagnostic Procedure with Diagnostic Trouble Code (DTC)

LAN SYSTEM (DIAGNOSTICS)

Step	Check	Yes	No
4 CHECK DTC. 1) Turn the ignition switch to OFF. 2) Disconnect the VDC CM connector. 3) Connect the disconnected connectors. 4) Read the DTC using Subaru Select Monitor.	Is U0416 a current malfunction?	Go to step 5.	Go to step 8.
5 CHECK DTC. Using the Subaru Select Monitor, read DTC of all the systems.	Is the VDC data abnormal detected in several modules?	Replace the VDC CM. <Ref. to VDC-9, VDC Control Module and Hydraulic Control Unit (VDCCM&H/U).>	Go to step 6.
6 REPLACE MODULE. 1) Replace the VDC CM. 2) Read the DTC using Subaru Select Monitor.	Is U0416 a current malfunction?	Go to step 7.	System is normal.
7 CHECK MODULE. 1) Reinstall the VDC CM. 2) Replace the module that the DTC has been detected. 3) Read the DTC using Subaru Select Monitor.	Is U0416 a current malfunction?	Replace the VDC CM. <Ref. to VDC-9, VDC Control Module and Hydraulic Control Unit (VDCCM&H/U).>	System is normal.
8 CHECK HARNESS. 1) Shake the harness, and check for poor contact. 2) Using the Subaru Select Monitor, read DTC of CAN system.	Is U0416 a current malfunction?	Repair the poor contact of harness, or replace the harness.	Go to step 9.
9 CHECK CONNECTOR. Check the connector used for high speed CAN for poor contact.	Is there poor contact of connector?	Repair the connector that has poor contact, or replace harness.	It is possible that temporary poor communication occurs. Delete the DTC.

Diagnostic Procedure with Diagnostic Trouble Code (DTC)

LAN SYSTEM (DIAGNOSTICS)

F: DTC U0420 INVALID DATA RECEIVED FROM POWER STEERING CONTROL MODULE

DTC DETECTING CONDITION:

Defective data was transmitted from EPS CM.

TROUBLE SYMPTOM:

Cooperation control with EPS CM does not operate properly.

WIRING DIAGRAM:

CAN communication system <Ref. to WI-46, WIRING DIAGRAM, CAN Communication System.>

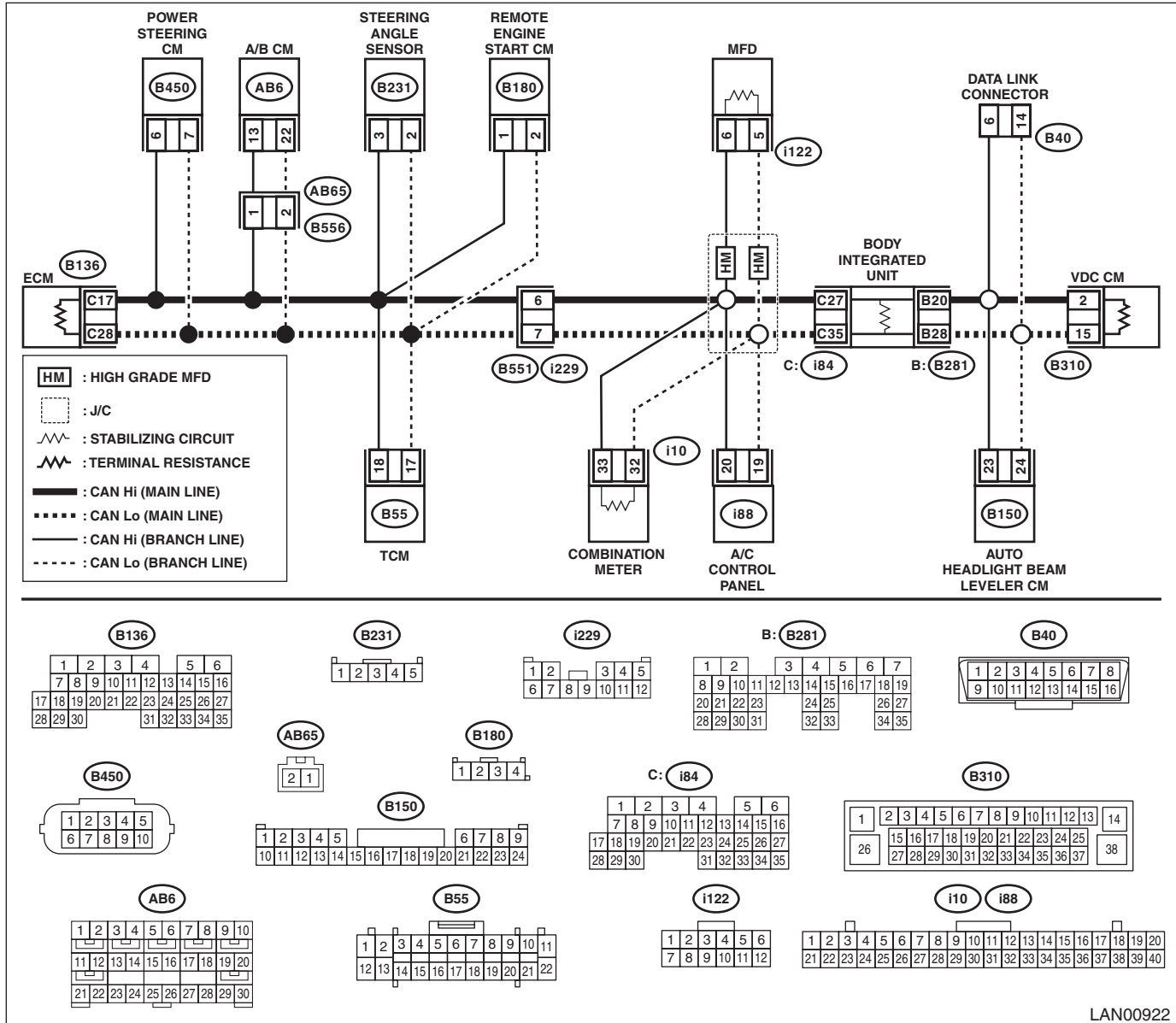

LAN00922

Step	Check	Yes	No
1	CHECK DTC. Check the displayed DTC.	Are DTCs other than U*** displayed?	Perform the diagnosis according to DTC. Go to step 2.
2	CHECK DTC. Check the displayed DTC.	Is DTC for the buss off or the data no-receive displayed?	Perform the diagnosis according to DTC. Go to step 3.
3	CHECK DTC. Check the displayed DTC.	Is U0420 a current malfunction?	Go to step 4. Go to step 8.

Diagnostic Procedure with Diagnostic Trouble Code (DTC)

LAN SYSTEM (DIAGNOSTICS)

Step	Check	Yes	No
4 CHECK DTC. 1) Turn the ignition switch to OFF. 2) Disconnect the power steering CM connector. 3) Connect the disconnected connectors. 4) Read the DTC using Subaru Select Monitor.	Is U0420 a current malfunction?	Go to step 5.	Go to step 8.
5 CHECK DTC. Using the Subaru Select Monitor, read DTC of all the systems.	Is the electric power steering data abnormal detected in several modules?	Replace the power steering CM. <Ref. to PS-42, Power Steering Control Module.>	Go to step 6.
6 REPLACE MODULE. 1) Replace the power steering CM. 2) Read the DTC using Subaru Select Monitor.	Is U0420 a current malfunction?	Go to step 7.	System is normal.
7 CHECK MODULE. 1) Reinstall the power steering CM. 2) Replace the module that the DTC has been detected. 3) Read the DTC using Subaru Select Monitor.	Is U0420 a current malfunction?	Replace the power steering CM. <Ref. to PS-42, Power Steering Control Module.>	System is normal.
8 CHECK HARNESS. 1) Shake the harness, and check for poor contact. 2) Using the Subaru Select Monitor, read DTC of CAN system.	Is U0420 a current malfunction?	Repair the poor contact of harness, or replace the harness.	Go to step 9.
9 CHECK CONNECTOR. Check the connector used for high speed CAN for poor contact.	Is there poor contact of connector?	Repair the connector that has poor contact, or replace harness.	It is possible that temporary poor communication occurs. Delete the DTC.

Diagnostic Procedure with Diagnostic Trouble Code (DTC)

LAN SYSTEM (DIAGNOSTICS)

G: DTC U0422 INVALID DATA RECEIVED FROM BODY CONTROL MODULE

DTC DETECTING CONDITION:

Defective data was transmitted from body integrated unit.

TROUBLE SYMPTOM:

Cooperation control with body integrated unit does not operate properly.

WIRING DIAGRAM:

CAN communication system <Ref. to WI-46, WIRING DIAGRAM, CAN Communication System.>

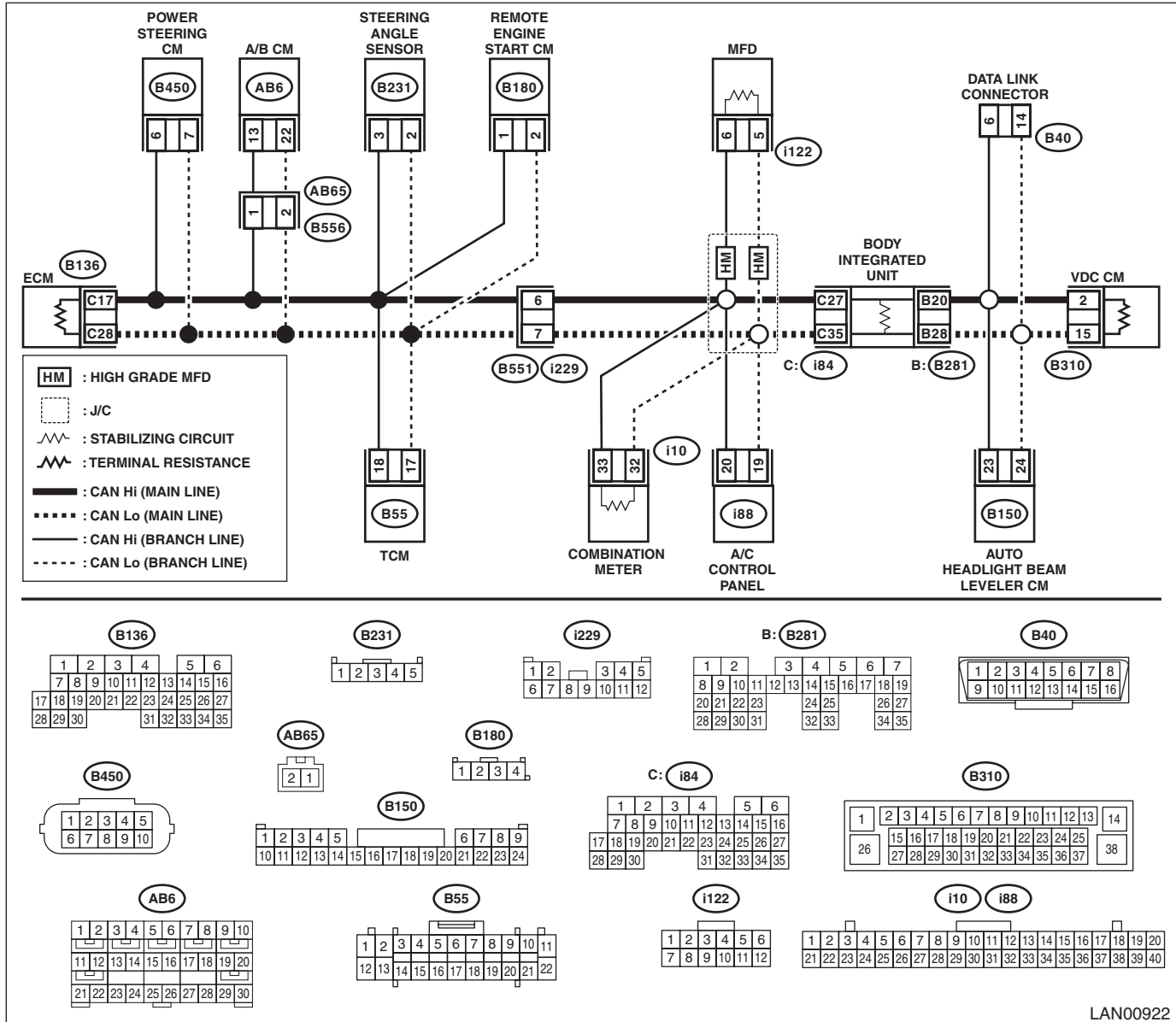

Step	Check	Yes	No
1	CHECK DTC. Check the displayed DTC.	Are DTCs other than U*** displayed?	Perform the diagnosis according to DTC. Go to step 2.
2	CHECK DTC. Check the displayed DTC.	Is DTC for the buss off or the data no-receive displayed?	Perform the diagnosis according to DTC. Go to step 3.
3	CHECK DTC. Check the displayed DTC.	Is U0422 a current malfunction?	Go to step 4. Go to step 8.

Diagnostic Procedure with Diagnostic Trouble Code (DTC)

LAN SYSTEM (DIAGNOSTICS)

Step	Check	Yes	No
4 CHECK DTC. 1) Turn the ignition switch to OFF. 2) Disconnect the body integrated unit connector. 3) Connect the disconnected connectors. 4) Read the DTC using Subaru Select Monitor.	Is U0422 a current malfunction?	Go to step 5.	Go to step 8.
5 CHECK DTC. Using the Subaru Select Monitor, read DTC of all the systems.	Is the body integrated data abnormal detected in several modules?	Replace the body integrated unit. <Ref. to SL-78, Body Integrated Unit.>	Go to step 6.
6 REPLACE MODULE. 1) Replace the body integrated unit. 2) Read the DTC using Subaru Select Monitor.	Is U0422 a current malfunction?	Go to step 7.	System is normal.
7 CHECK MODULE. 1) Reinstall the body integrated unit. 2) Replace the module that the DTC has been detected. 3) Read the DTC using Subaru Select Monitor.	Is U0422 a current malfunction?	Replace the body integrated unit. <Ref. to SL-78, Body Integrated Unit.>	System is normal.
8 CHECK HARNESS. 1) Shake the harness, and check for poor contact. 2) Using the Subaru Select Monitor, read DTC of CAN system.	Is U0422 a current malfunction?	Repair the poor contact of harness, or replace the harness.	Go to step 9.
9 CHECK CONNECTOR. Check the connector used for high speed CAN for poor contact.	Is there poor contact of connector?	Repair the connector that has poor contact, or replace harness.	It is possible that temporary poor communication occurs. Delete the DTC.

Diagnostic Procedure with Diagnostic Trouble Code (DTC)

LAN SYSTEM (DIAGNOSTICS)

H: DTC U0423 INVALID DATA RECEIVED FROM INSTRUMENT PANEL CLUSTER CONTROL MODULE

DTC DETECTING CONDITION:

Defective data was transmitted from combination meter.

TROUBLE SYMPTOM:

Display of combination meter does not operate properly.

WIRING DIAGRAM:

CAN communication system <Ref. to WI-46, WIRING DIAGRAM, CAN Communication System.>

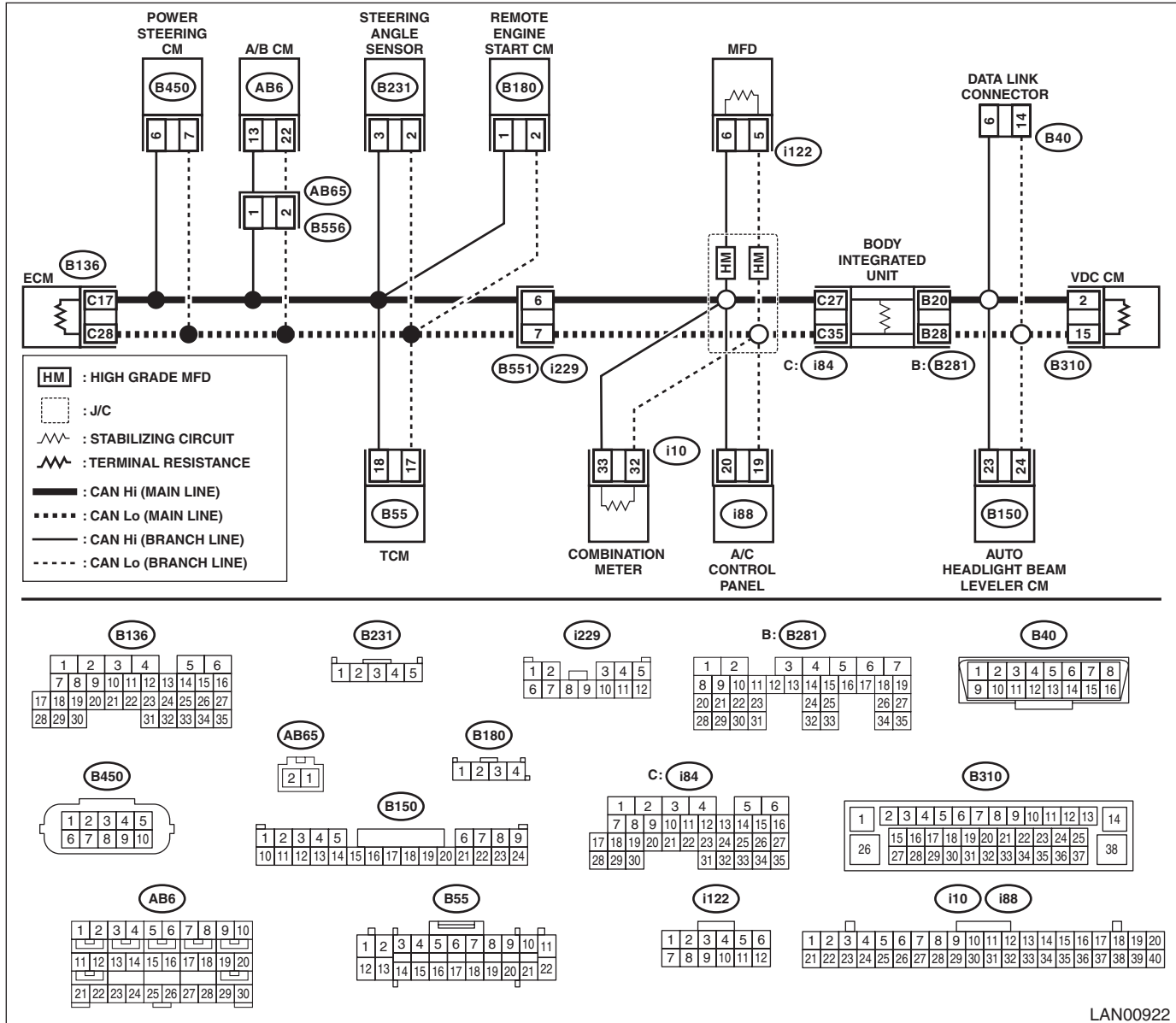

LAN00922

Step	Check	Yes	No
1	CHECK DTC. Check the displayed DTC.	Are DTCs other than U*** displayed?	Perform the diagnosis according to DTC. Go to step 2.
2	CHECK DTC. Check the displayed DTC.	Is DTC for the buss off or the data no-receive displayed?	Perform the diagnosis according to DTC. Go to step 3.
3	CHECK DTC. Check the displayed DTC.	Is U0423 a current malfunction?	Go to step 4. Go to step 8.

Diagnostic Procedure with Diagnostic Trouble Code (DTC)

LAN SYSTEM (DIAGNOSTICS)

Step	Check	Yes	No
4 CHECK DTC. 1) Turn the ignition switch to OFF. 2) Disconnect the combination meter connector. 3) Connect the disconnected connectors. 4) Read the DTC using Subaru Select Monitor.	Is U0423 a current malfunction?	Go to step 5.	Go to step 8.
5 CHECK DTC. Using the Subaru Select Monitor, read DTC of all the systems.	Is the meter data abnormal detected in several modules?	Replace the combination meter. <Ref. to IDI-17, Combination Meter.>	Go to step 6.
6 REPLACE MODULE. 1) Replace the combination meter. 2) Read the DTC using Subaru Select Monitor.	Is U0423 a current malfunction?	Go to step 7.	System is normal.
7 CHECK MODULE. 1) Replace the current combination meter with the original combination meter. 2) Replace the module that the DTC has been detected. 3) Read the DTC using Subaru Select Monitor.	Is U0423 a current malfunction?	Replace the combination meter. <Ref. to IDI-17, Combination Meter.>	System is normal.
8 CHECK HARNESS. 1) Shake the harness, and check for poor contact. 2) Using the Subaru Select Monitor, read DTC of CAN system.	Is U0423 a current malfunction?	Repair the poor contact of harness, or replace the harness.	Go to step 9.
9 CHECK CONNECTOR. Check the connector used for high speed CAN for poor contact.	Is there poor contact of connector?	Repair the connector that has poor contact, or replace harness.	It is possible that temporary poor communication occurs. Delete the DTC.

Diagnostic Procedure with Diagnostic Trouble Code (DTC)

LAN SYSTEM (DIAGNOSTICS)

I: DTC U0424 INVALID DATA RECEIVED FROM HVAC CONTROL MODULE

DTC DETECTING CONDITION:

Defective data was transmitted from A/C control panel.

TROUBLE SYMPTOM:

Cooperation control of air conditioner does not operate properly.

WIRING DIAGRAM:

CAN communication system <Ref. to WI-46, WIRING DIAGRAM, CAN Communication System.>

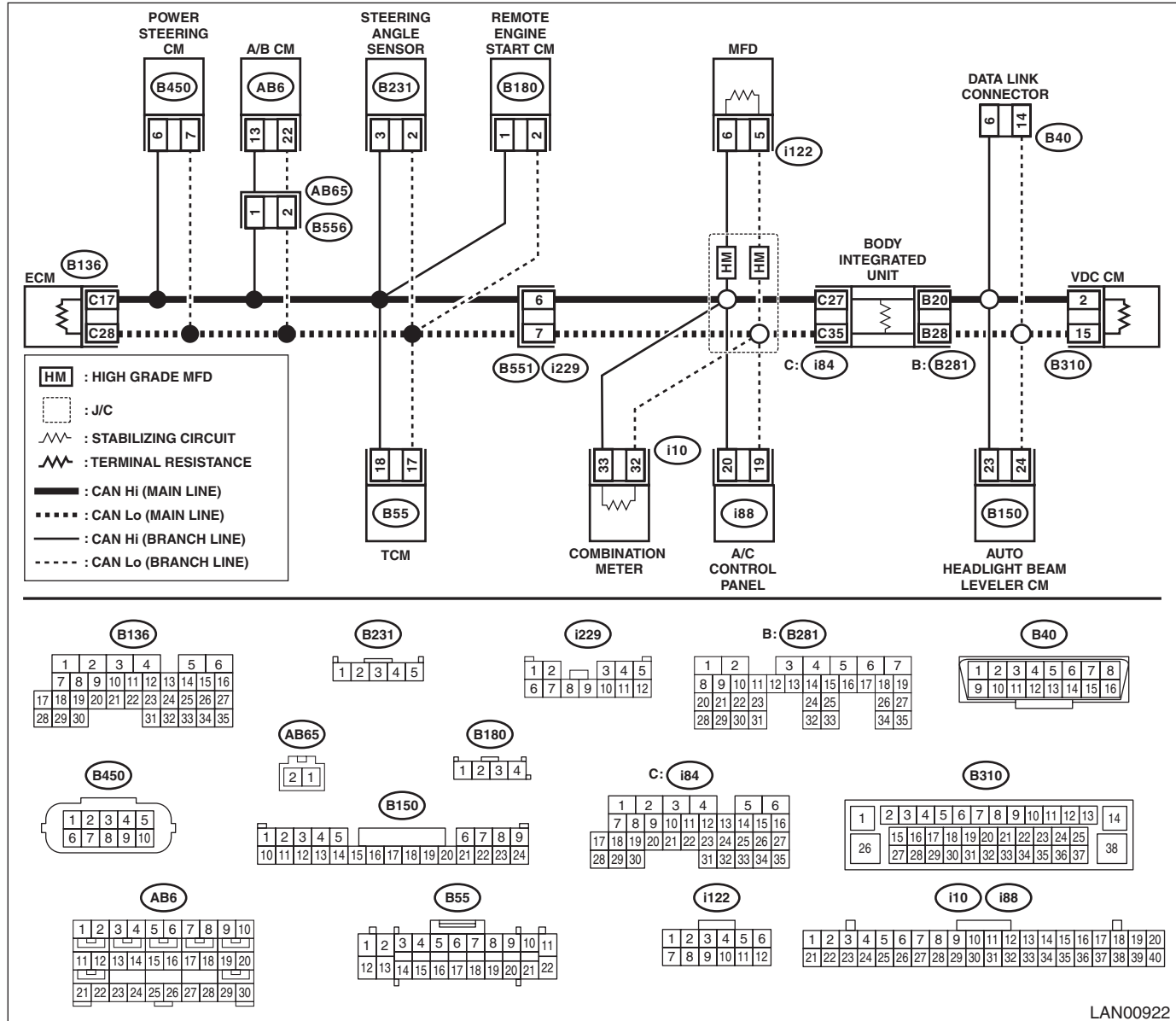

Step	Check	Yes	No
1	CHECK DTC. Check the displayed DTC.	Are DTCs other than U*** displayed?	Perform the diagnosis according to DTC. Go to step 2.
2	CHECK DTC. Check the displayed DTC.	Is DTC for the buss off or the data no-receive displayed?	Perform the diagnosis according to DTC. Go to step 3.
3	CHECK DTC. Check the displayed DTC.	Is U0424 a current malfunction?	Go to step 4. Go to step 8.

Diagnostic Procedure with Diagnostic Trouble Code (DTC)

LAN SYSTEM (DIAGNOSTICS)

Step	Check	Yes	No
4 CHECK DTC. 1) Turn the ignition switch to OFF. 2) Disconnect the A/C control panel connector. 3) Connect the disconnected connectors. 4) Read the DTC using Subaru Select Monitor.	Is U0424 a current malfunction?	Go to step 5.	Go to step 8.
5 CHECK DTC. Using the Subaru Select Monitor, read DTC of all the systems.	Is the air conditioner data abnormal detected in several modules?	Replace the A/C control panel.	Go to step 6.
6 REPLACE MODULE. 1) Replace the A/C control panel. 2) Read the DTC using Subaru Select Monitor.	Is U0424 a current malfunction?	Go to step 7.	System is normal.
7 CHECK MODULE. 1) Restore the A/C control panel. 2) Replace the module that the DTC has been detected. 3) Read the DTC using Subaru Select Monitor.	Is U0424 a current malfunction?	Replace the A/C control panel.	System is normal.
8 CHECK HARNESS. 1) Shake the harness, and check for poor contact. 2) Read the DTC using Subaru Select Monitor.	Is U0424 a current malfunction?	Repair the poor contact of harness, or replace the harness.	Go to step 9.
9 CHECK CONNECTOR. Check the connector used for high speed CAN for poor contact.	Is there poor contact of connector?	Repair the connector that has poor contact, or replace harness.	It is possible that temporary poor communication occurs. Delete the DTC.

Diagnostic Procedure with Diagnostic Trouble Code (DTC)

LAN SYSTEM (DIAGNOSTICS)

J: DTC U0428 INVALID DATA RECEIVED FROM STEERING ANGLE SENSOR MODULE

DTC DETECTING CONDITION:

Defective data was transmitted from steering angle sensor.

TROUBLE SYMPTOM:

VDC CM does not operate normally.

WIRING DIAGRAM:

CAN communication system <Ref. to WI-46, WIRING DIAGRAM, CAN Communication System.>

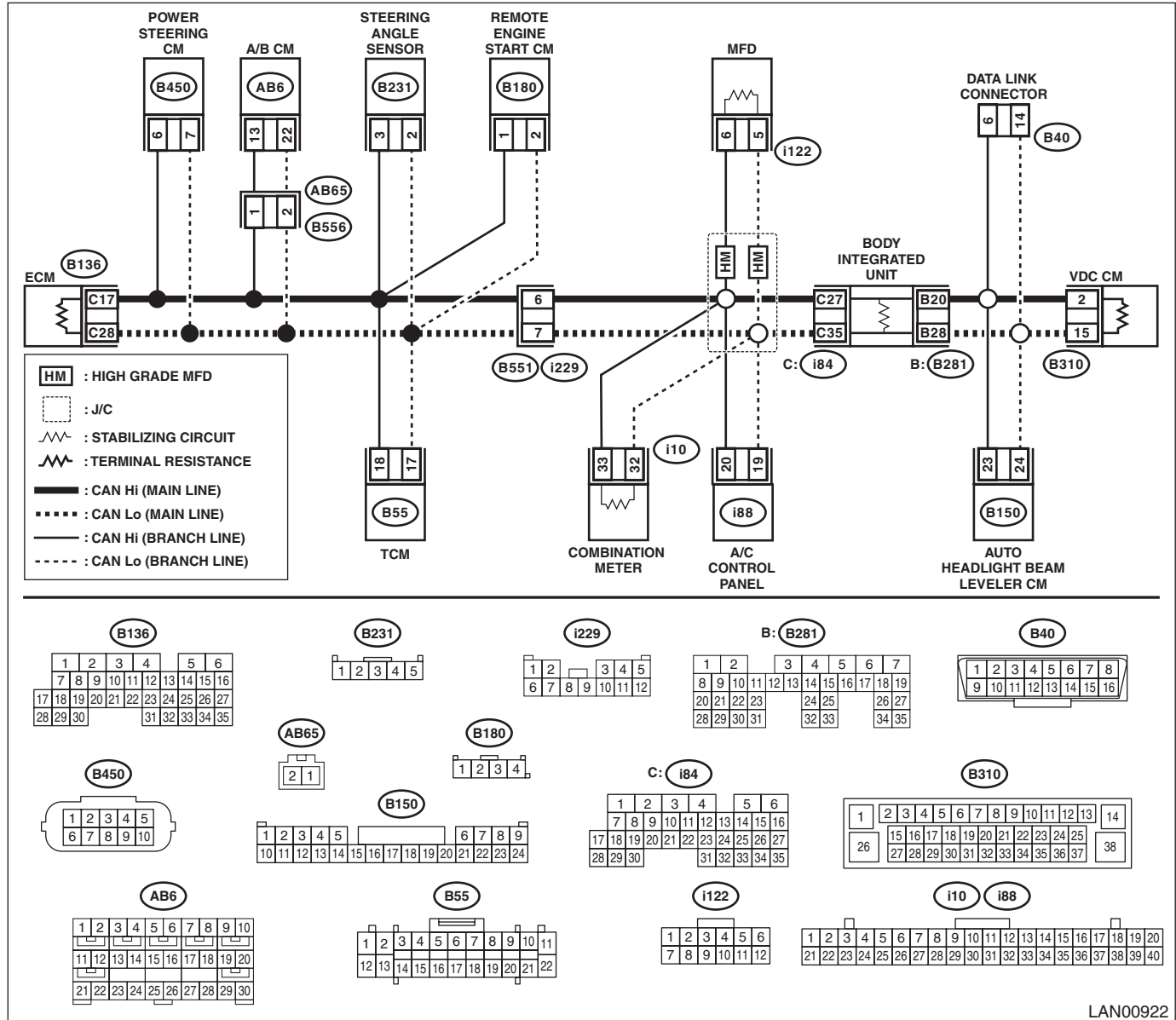

LAN00922

Step	Check	Yes	No
1	CHECK DTC. Check the displayed DTC.	Are DTCs other than U*** displayed?	Perform the diagnosis according to DTC. Go to step 2.
2	CHECK DTC. Check the displayed DTC.	Is DTC for the buss off or the data no-receive displayed?	Perform the diagnosis according to DTC. Go to step 3.
3	CHECK DTC. Check the displayed DTC.	Is U0428 a current malfunction?	Go to step 4. Go to step 8.

Diagnostic Procedure with Diagnostic Trouble Code (DTC)

LAN SYSTEM (DIAGNOSTICS)

Step	Check	Yes	No
4 CHECK DTC. 1) Turn the ignition switch to OFF. 2) Disconnect the steering angle sensor connector. 3) Connect the disconnected connectors. 4) Read the DTC using Subaru Select Monitor.	Is U0428 a current malfunction?	Go to step 5.	Go to step 8.
5 CHECK DTC. Using the Subaru Select Monitor, read DTC of all the systems.	Is the steering angle sensor data abnormal detected in several modules?	Replace the steering angle sensor. <Ref. to VDC-27, Steering Angle Sensor.>	Go to step 6.
6 REPLACE MODULE. 1) Replace the steering angle sensor. 2) Read the DTC using Subaru Select Monitor.	Is U0428 a current malfunction?	Go to step 7.	System is normal.
7 CHECK MODULE. 1) Reinstall the steering angle sensor. 2) Replace the module that the DTC has been detected. 3) Read the DTC using Subaru Select Monitor.	Is U0428 a current malfunction?	Replace the steering angle sensor. <Ref. to VDC-27, Steering Angle Sensor.>	System is normal.
8 CHECK HARNESS. 1) Shake the harness, and check for poor contact. 2) Using the Subaru Select Monitor, read DTC of CAN system.	Is U0428 a current malfunction?	Repair the poor contact of harness, or replace the harness.	Go to step 9.
9 CHECK CONNECTOR. Check the connector used for high speed CAN for poor contact.	Is there poor contact of connector?	Repair the connector that has poor contact, or replace harness.	It is possible that temporary poor communication occurs. Delete the DTC.

Diagnostic Procedure with Diagnostic Trouble Code (DTC)

LAN SYSTEM (DIAGNOSTICS)

K: DTC U0452 INVALID DATA RECEIVED FROM RESTRAINTS CONTROL MODULE

DTC DETECTING CONDITION:

Defective data was transmitted from A/B CM.

TROUBLE SYMPTOM:

Cooperation control with airbag does not operate properly.

WIRING DIAGRAM:

CAN communication system <Ref. to WI-46, WIRING DIAGRAM, CAN Communication System.>

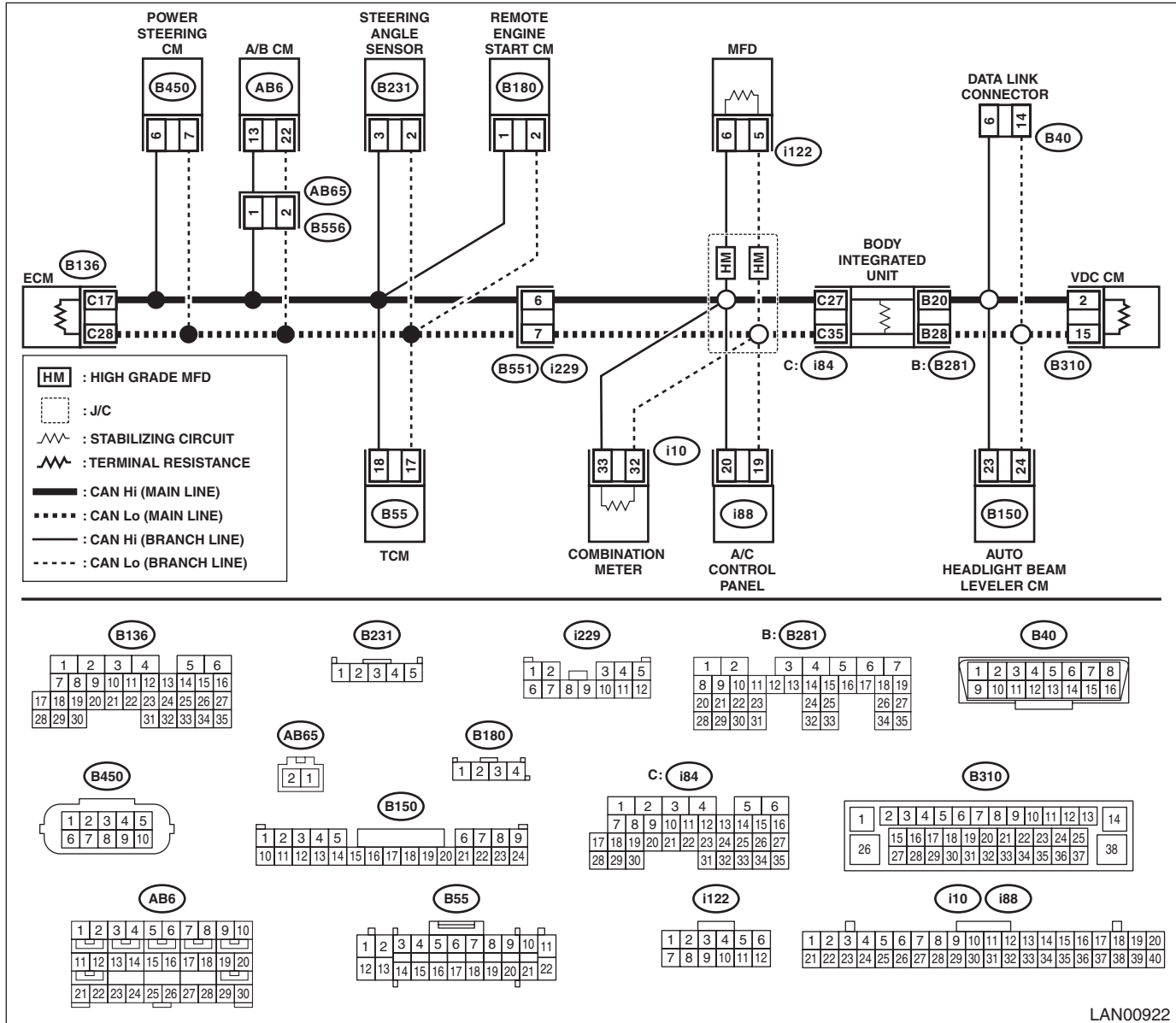

LAN00922

Step	Check	Yes	No
1	CHECK DTC. Check the displayed DTC.	Are DTCs other than U*** displayed?	Perform the diagnosis according to DTC. Go to step 2.
2	CHECK DTC. Check the displayed DTC.	Is DTC for the buss off or the data no-receive displayed?	Perform the diagnosis according to DTC. Go to step 3.
3	CHECK DTC. Check the displayed DTC.	Is U0452 a current malfunction?	Go to step 4. Go to step 8.

Diagnostic Procedure with Diagnostic Trouble Code (DTC)

LAN SYSTEM (DIAGNOSTICS)

Step	Check	Yes	No
4 CHECK DTC. 1) Turn the ignition switch to OFF. 2) Disconnect the A/B CM connector. 3) Connect the disconnected connectors. 4) Read the DTC using Subaru Select Monitor.	Is U0452 a current malfunction?	Go to step 5.	Go to step 8.
5 CHECK DTC. Using the Subaru Select Monitor, read DTC of all the systems.	Is the airbag data abnormal detected in several modules?	Replace the A/B CM. <Ref. to AB-77, Airbag Control Module.>	Go to step 6.
6 REPLACE MODULE. 1) Replace the A/B CM. 2) Read the DTC using Subaru Select Monitor.	Is U0452 a current malfunction?	Go to step 7.	System is normal.
7 CHECK MODULE. 1) Reinstall the A/B CM. 2) Replace the module that the DTC has been detected. 3) Read the DTC using Subaru Select Monitor.	Is U0452 a current malfunction?	Replace the A/B CM. <Ref. to AB-77, Airbag Control Module.>	System is normal.
8 CHECK HARNESS. 1) Shake the harness, and check for poor contact. 2) Using the Subaru Select Monitor, read DTC of CAN system.	Is U0452 a current malfunction?	Repair the poor contact of harness, or replace the harness.	Go to step 9.
9 CHECK CONNECTOR. Check the connector used for high speed CAN for poor contact.	Is there poor contact of connector?	Repair the connector that has poor contact, or replace harness.	It is possible that temporary poor communication occurs. Delete the DTC.

Diagnostic Procedure with Diagnostic Trouble Code (DTC)

LAN SYSTEM (DIAGNOSTICS)

L: DTC U0100 LOST COMMUNICATION WITH ECM/PCM "A"

DTC DETECTING CONDITION:

Not received data from ECM.

TROUBLE SYMPTOM:

Cooperation control of transmission may not operate properly.

WIRING DIAGRAM:

CAN communication system <Ref. to WI-46, WIRING DIAGRAM, CAN Communication System.>

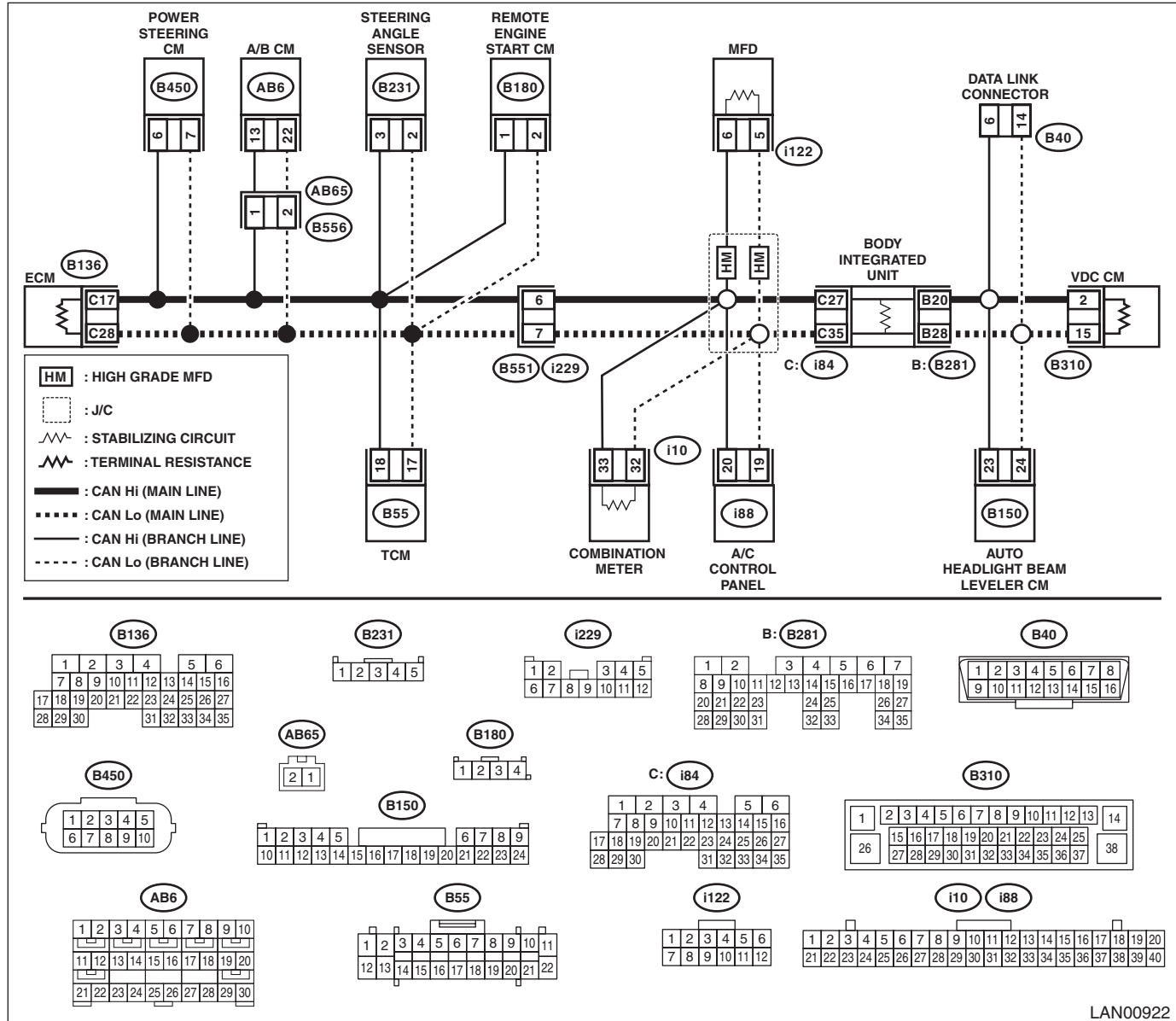

Step	Check	Yes	No
1	CHECK DTC. Check the displayed DTC.	Are DTCs other than U*** displayed?	Perform the diagnosis according to DTC. Go to step 2.
2	CHECK DTC. Check the displayed DTC.	Is U0100 a current malfunction?	Go to step 3. Go to step 7.
3	CHECK DTC. 1) Check CAN communication circuit. <Ref. to LAN(diag)-24, CAN Communication Circuit Check.> 2) Read the DTC using Subaru Select Monitor.	Is U0100 a current malfunction?	Go to step 4. Go to step 7.

Diagnostic Procedure with Diagnostic Trouble Code (DTC)

LAN SYSTEM (DIAGNOSTICS)

Step	Check	Yes	No
4 CHECK DTC. Using the Subaru Select Monitor, read DTC of all the systems.	Is the engine data no-receive detected in several modules?	Replace the ECM. <Ref. to FU(H4DO)-102, Engine Control Module (ECM).>	Go to step 5 .
5 REPLACE MODULE. 1) Replace the ECM. 2) Read the DTC using Subaru Select Monitor.	Is U0100 a current malfunction?	Go to step 6 .	System is normal.
6 CHECK MODULE. 1) Reinstall the ECM. 2) Replace the module that the DTC has been detected. 3) Read the DTC using Subaru Select Monitor.	Is U0100 a current malfunction?	Replace the ECM. <Ref. to FU(H4DO)-102, Engine Control Module (ECM).>	System is normal.
7 CHECK HARNESS. 1) Shake the harness, and check for poor contact. 2) Read the DTC using Subaru Select Monitor.	Is U0100 a current malfunction?	Repair the poor contact of harness, or replace the harness.	Go to step 8 .
8 CHECK CONNECTOR. Check the connector used for high speed CAN for poor contact.	Is there poor contact of connector?	Repair the connector that has poor contact, or replace harness.	It is possible that temporary poor communication occurs. Delete the DTC.

Diagnostic Procedure with Diagnostic Trouble Code (DTC)

LAN SYSTEM (DIAGNOSTICS)

M: DTC U0101 LOST COMMUNICATION WITH TCM

DTC DETECTING CONDITION:

Not received data from TCM.

TROUBLE SYMPTOM:

Cooperation control with transmission is not performed.

WIRING DIAGRAM:

CAN communication system <Ref. to WI-46, WIRING DIAGRAM, CAN Communication System.>

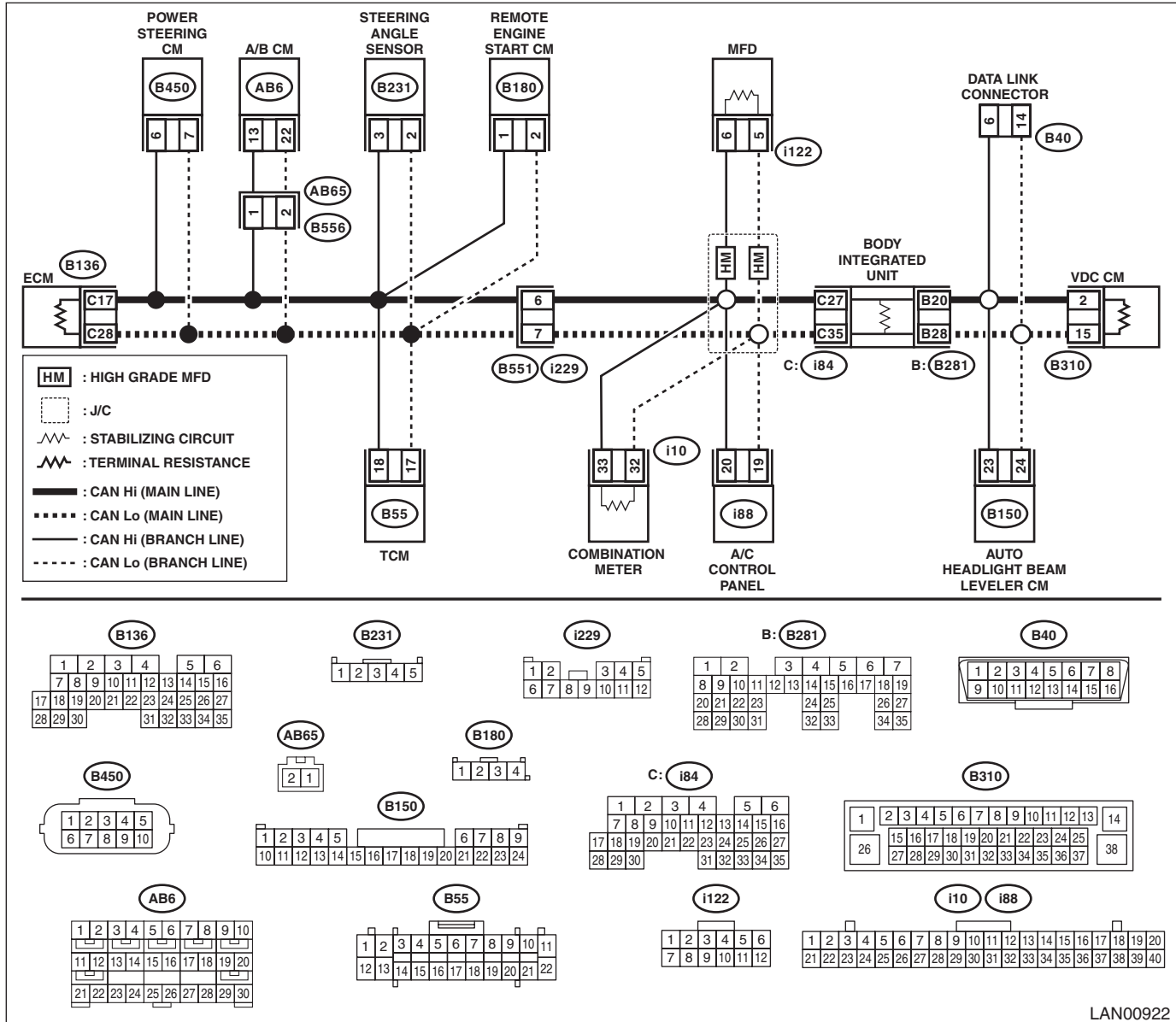

LAN00922

Step	Check	Yes	No
1	CHECK DTC. Check the displayed DTC.	Are DTCs other than U*** displayed?	Perform the diagnosis according to DTC. Go to step 2.
2	CHECK DTC. Check the displayed DTC.	Is U0101 a current malfunction?	Go to step 3. Go to step 7.
3	CHECK DTC. 1) Check CAN communication circuit. <Ref. to LAN(diag)-24, CAN Communication Circuit Check.> 2) Read the DTC using Subaru Select Monitor.	Is U0101 a current malfunction?	Go to step 4. Go to step 7.

Diagnostic Procedure with Diagnostic Trouble Code (DTC)

LAN SYSTEM (DIAGNOSTICS)

Step	Check	Yes	No
4 CHECK DTC. Using the Subaru Select Monitor, read DTC of all the systems.	Is the transmission data no-receive detected in several modules?	Replace the TCM. <Ref. to CVT-136, Transmission Control Module (TCM).>	Go to step 5 .
5 REPLACE MODULE. 1) Replace the TCM. 2) Read the DTC using Subaru Select Monitor.	Is U0101 a current malfunction?	Go to step 6 .	System is normal.
6 CHECK MODULE. 1) Reinstall the TCM. 2) Replace the module that the DTC has been detected. 3) Read the DTC using Subaru Select Monitor.	Is U0101 a current malfunction?	Replace the TCM. <Ref. to CVT-136, Transmission Control Module (TCM).>	System is normal.
7 CHECK HARNESS. 1) Shake the harness, and check for poor contact. 2) Read the DTC using Subaru Select Monitor.	Is U0101 a current malfunction?	Repair the poor contact of harness, or replace the harness.	Go to step 8 .
8 CHECK CONNECTOR. Check the connector used for high speed CAN for poor contact.	Is there poor contact of connector?	Repair the connector that has poor contact, or replace harness.	It is possible that temporary poor communication occurs. Delete the DTC.

Diagnostic Procedure with Diagnostic Trouble Code (DTC)

LAN SYSTEM (DIAGNOSTICS)

N: DTC U0122 LOST COMMUNICATION WITH VEHICLE DYNAMICS CONTROL MODULE

DTC DETECTING CONDITION:

No data from VDCCM is received.

TROUBLE SYMPTOM:

ABS warning light and VDC warning light illuminate.

WIRING DIAGRAM:

CAN communication system <Ref. to WI-46, WIRING DIAGRAM, CAN Communication System.>

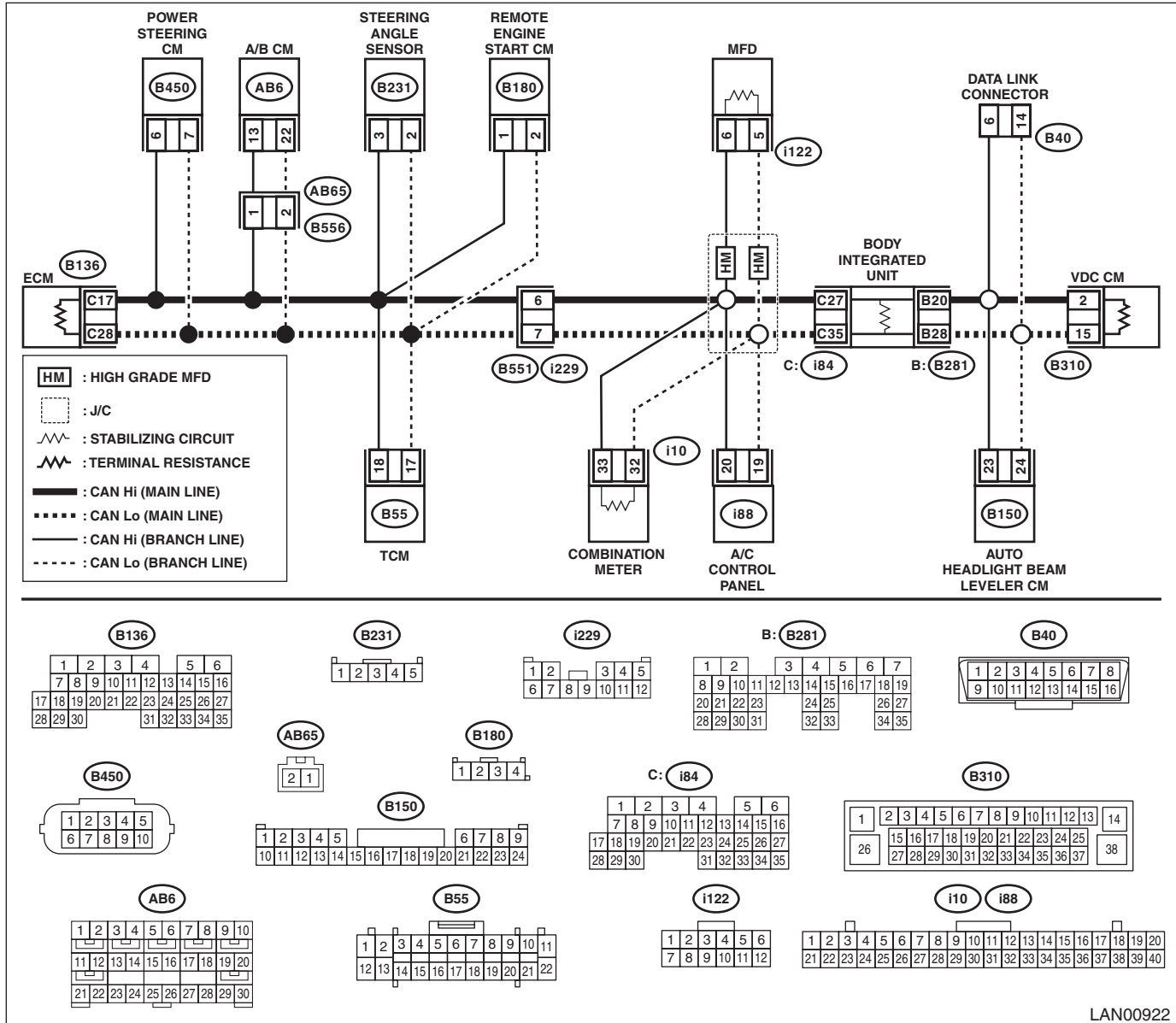

LAN00922

Step	Check	Yes	No	
1	CHECK DTC. Check the displayed DTC.	Are DTCs other than U*** displayed?	Perform the diagnosis according to DTC.	Go to step 2.
2	CHECK DTC. Check the displayed DTC.	Is U0122 a current malfunction?	Go to step 3.	Go to step 7.

Diagnostic Procedure with Diagnostic Trouble Code (DTC)

LAN SYSTEM (DIAGNOSTICS)

Step	Check	Yes	No
3 CHECK DTC. 1) Check CAN communication circuit. <Ref. to LAN(diag)-24, CAN Communication Circuit Check.> 2) Read the DTC using Subaru Select Monitor.	Is U0122 a current malfunction?	Go to step 4.	Go to step 7.
4 CHECK DTC. Using the Subaru Select Monitor, read DTC of all the systems.	Is the VDC data no-receive detected in several modules?	Replace the VDC CM. <Ref. to VDC-9, VDC Control Module and Hydraulic Control Unit (VDCCM&H/U).>	Go to step 5.
5 REPLACE MODULE. 1) Replace the VDC CM. 2) Read the DTC using Subaru Select Monitor.	Is U0122 a current malfunction?	Go to step 6.	System is normal.
6 CHECK MODULE. 1) Reinstall the VDC CM. 2) Replace the module that the DTC has been detected. 3) Read the DTC using Subaru Select Monitor.	Is U0122 a current malfunction?	Replace the VDC CM. <Ref. to VDC-9, VDC Control Module and Hydraulic Control Unit (VDCCM&H/U).>	System is normal.
7 CHECK HARNESS. 1) Shake the harness, and check for poor contact. 2) Read the DTC using Subaru Select Monitor.	Is U0122 a current malfunction?	Repair the poor contact of harness, or replace the harness.	Go to step 8.
8 CHECK CONNECTOR. Check the connector used for high speed CAN for poor contact.	Is there poor contact of connector?	Repair the connector that has poor contact, or replace harness.	It is possible that temporary poor communication occurs. Delete the DTC.

Diagnostic Procedure with Diagnostic Trouble Code (DTC)

LAN SYSTEM (DIAGNOSTICS)

O: DTC U0126 LOST COMMUNICATION WITH STEERING ANGLE SENSOR MODULE

DTC DETECTING CONDITION:

No data is received from steering angle sensor.

TROUBLE SYMPTOM:

VDC CM does not operate normally.

WIRING DIAGRAM:

CAN communication system <Ref. to WI-46, WIRING DIAGRAM, CAN Communication System.>

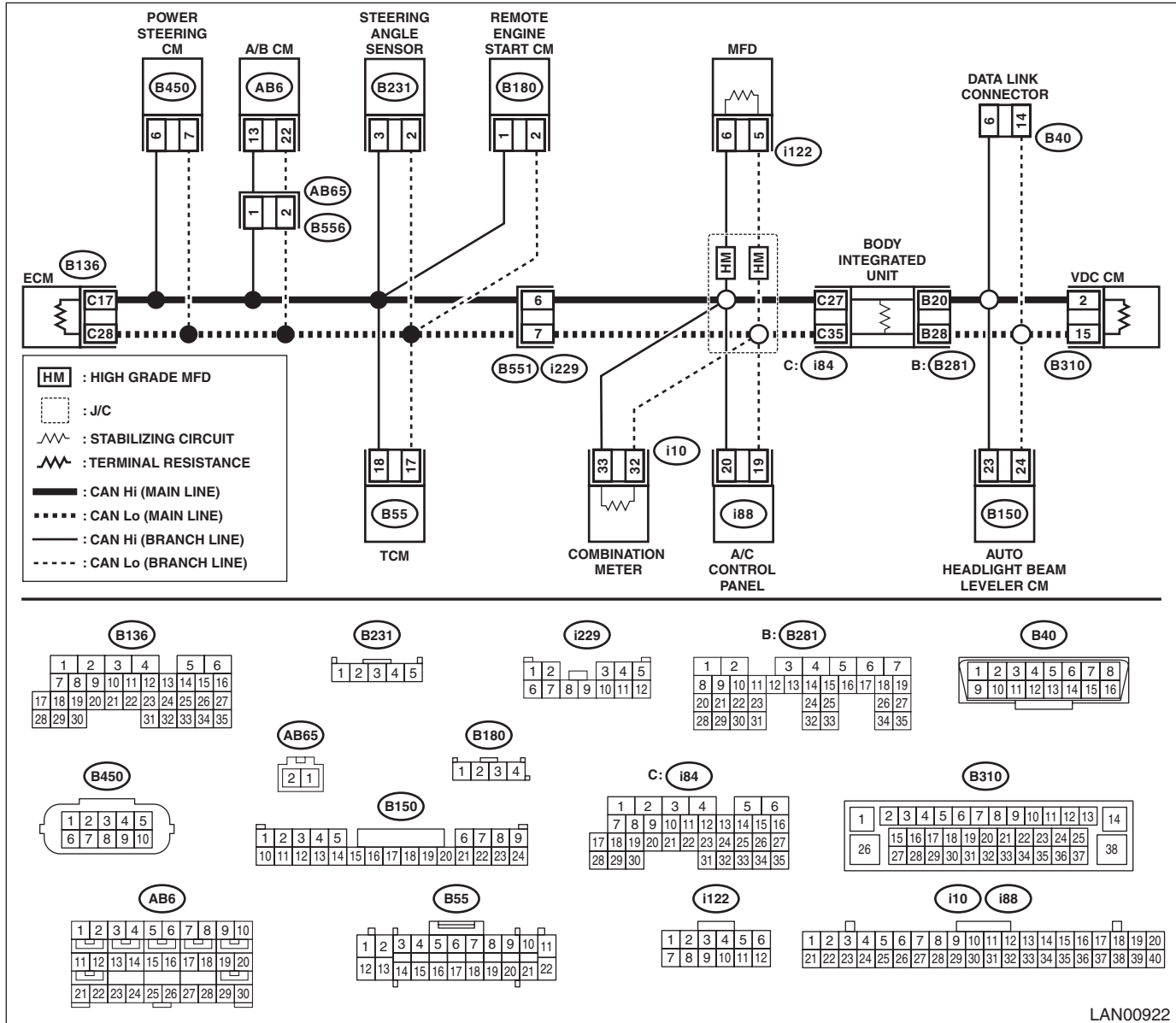

LAN00922

Step	Check	Yes	No
1	CHECK DTC. Check the displayed DTC.	Are DTCs other than U*** displayed?	Perform the diagnosis according to DTC. Go to step 2.
2	CHECK DTC. Check the displayed DTC.	Is U0126 a current malfunction?	Go to step 3. Go to step 7.

Diagnostic Procedure with Diagnostic Trouble Code (DTC)

LAN SYSTEM (DIAGNOSTICS)

Step	Check	Yes	No
3 CHECK DTC. 1) Check CAN communication circuit. <Ref. to LAN(diag)-24, CAN Communication Circuit Check.> 2) Read the DTC using Subaru Select Monitor.	Is U0126 a current malfunction?	Go to step 4.	Go to step 7.
4 CHECK DTC. Using the Subaru Select Monitor, read DTC of all the systems.	Is the steering angle sensor data no-receive detected in several modules?	Replace the steering angle sensor. <Ref. to VDC-27, Steering Angle Sensor.>	Go to step 5.
5 REPLACE MODULE. 1) Replace the steering angle sensor. 2) Read the DTC using Subaru Select Monitor.	Is U0126 a current malfunction?	Go to step 6.	System is normal.
6 CHECK MODULE. 1) Reinstall the steering angle sensor. 2) Replace the module that the DTC has been detected. 3) Read the DTC using Subaru Select Monitor.	Is U0126 a current malfunction?	Replace the steering angle sensor. <Ref. to VDC-27, Steering Angle Sensor.>	System is normal.
7 CHECK HARNESS. 1) Shake the harness, and check for poor contact. 2) Read the DTC using Subaru Select Monitor.	Is U0126 a current malfunction?	Repair the poor contact of harness, or replace the harness.	Go to step 8.
8 CHECK CONNECTOR. Check the connector used for high speed CAN for poor contact.	Is there poor contact of connector?	Repair the connector that has poor contact, or replace harness.	It is possible that temporary poor communication occurs. Delete the DTC.

Diagnostic Procedure with Diagnostic Trouble Code (DTC)

LAN SYSTEM (DIAGNOSTICS)

P: DTC U0131 LOST COMMUNICATION WITH POWER STEERING CONTROL MODULE

DTC DETECTING CONDITION:

No data is received from power steering CM.

TROUBLE SYMPTOM:

Cooperation control with power steering CM does not operate properly.

WIRING DIAGRAM:

CAN communication system <Ref. to WI-46, WIRING DIAGRAM, CAN Communication System.>

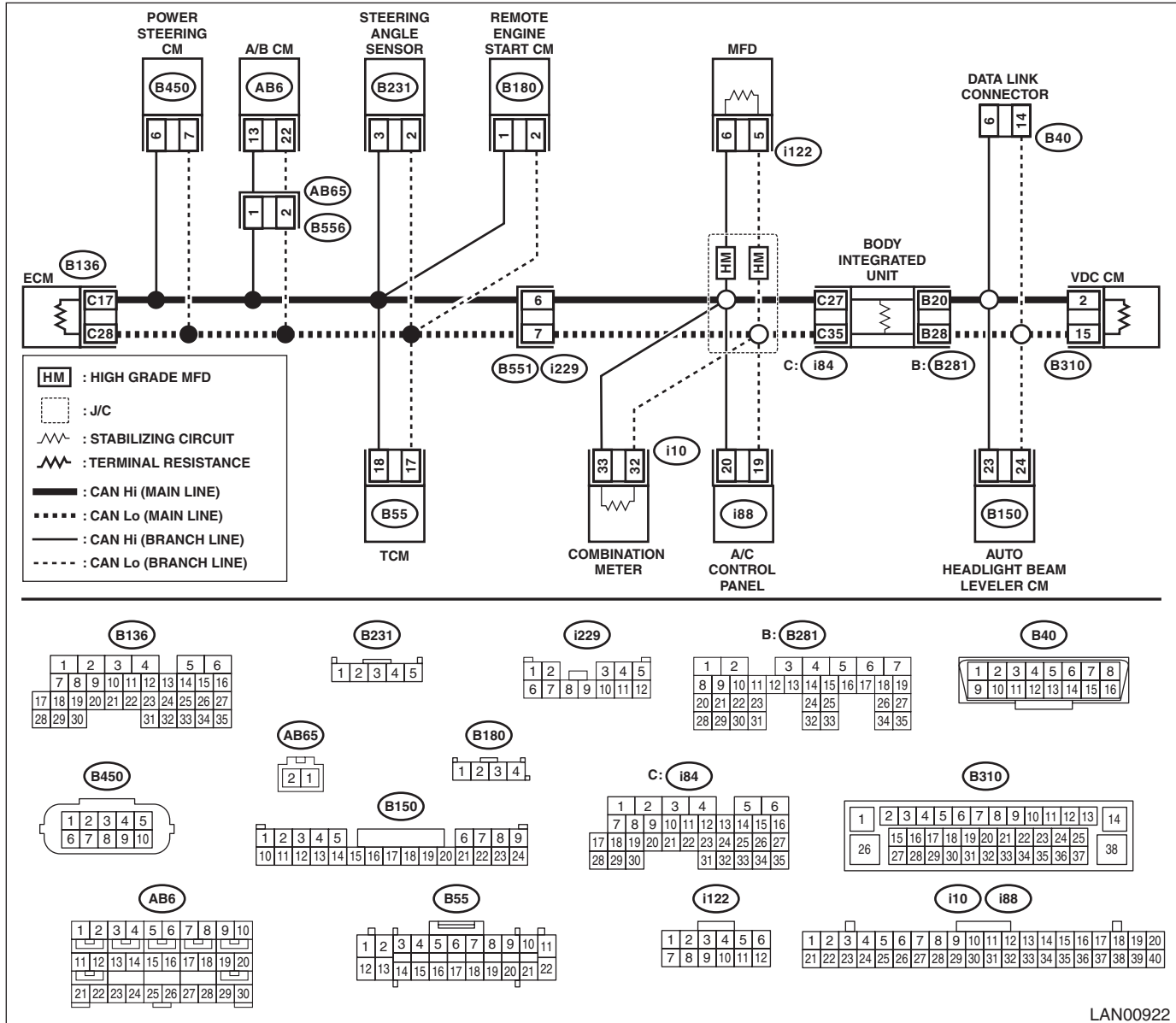

LAN00922

Step	Check	Yes	No
1	CHECK DTC. Check the displayed DTC.	Are DTCs other than U*** displayed?	Perform the diagnosis according to DTC. Go to step 2.
2	CHECK DTC. Check the displayed DTC.	Is U0131 a current malfunction?	Go to step 3. Go to step 7.

Diagnostic Procedure with Diagnostic Trouble Code (DTC)

LAN SYSTEM (DIAGNOSTICS)

Step	Check	Yes	No
3 CHECK DTC. 1) Check CAN communication circuit. <Ref. to LAN(diag)-24, CAN Communication Circuit Check.> 2) Read the DTC using Subaru Select Monitor.	Is U0131 a current malfunction?	Go to step 4.	Go to step 7.
4 CHECK DTC. Using the Subaru Select Monitor, read DTC of all the systems.	Is the electric power steering data no-receive detected in several modules?	Replace the power steering CM. <Ref. to PS-42, Power Steering Control Module.>	Go to step 5.
5 REPLACE MODULE. 1) Replace the power steering CM. 2) Read the DTC using Subaru Select Monitor.	Is U0131 a current malfunction?	Go to step 6.	System is normal.
6 CHECK MODULE. 1) Reinstall the power steering CM. 2) Replace the module that the DTC has been detected. 3) Read the DTC using Subaru Select Monitor.	Is U0131 a current malfunction?	Replace the power steering CM. <Ref. to PS-42, Power Steering Control Module.>	System is normal.
7 CHECK HARNESS. 1) Shake the harness, and check for poor contact. 2) Read the DTC using Subaru Select Monitor.	Is U0131 a current malfunction?	Repair the poor contact of harness, or replace the harness.	Go to step 8.
8 CHECK CONNECTOR. Check the connector used for high speed CAN for poor contact.	Is there poor contact of connector?	Repair the connector that has poor contact, or replace harness.	It is possible that temporary poor communication occurs. Delete the DTC.

Diagnostic Procedure with Diagnostic Trouble Code (DTC)

LAN SYSTEM (DIAGNOSTICS)

Q: DTC U0140 LOST COMMUNICATION WITH BODY CONTROL MODULE

DTC DETECTING CONDITION:

No data is received from body integrated unit.

TROUBLE SYMPTOM:

Cooperation control with body integrated unit does not operate properly.

WIRING DIAGRAM:

CAN communication system <Ref. to WI-46, WIRING DIAGRAM, CAN Communication System.>

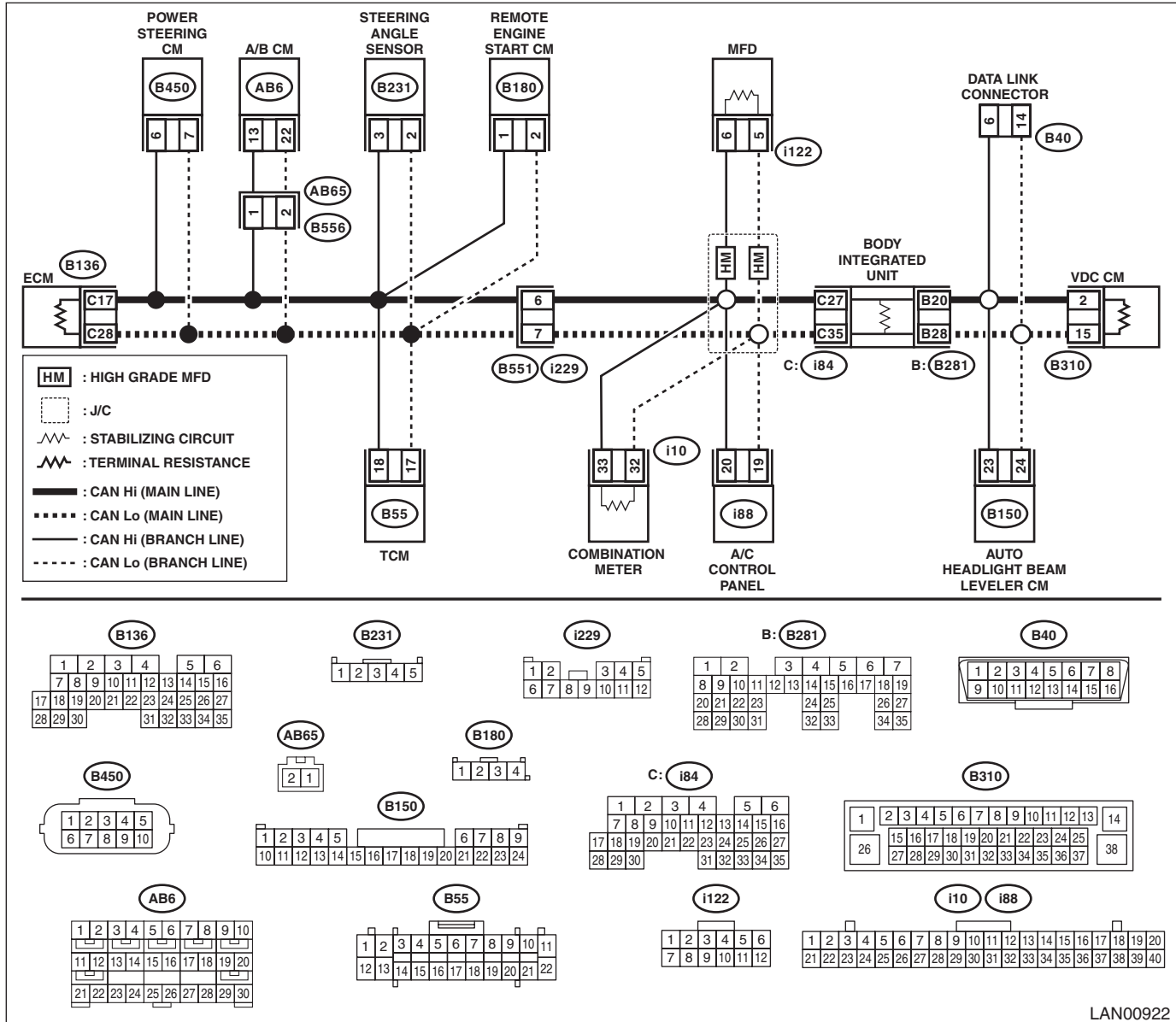

LAN00922

Step	Check	Yes	No
1	CHECK DTC. Check the displayed DTC.	Are DTCs other than U*** displayed?	Perform the diagnosis according to DTC. Go to step 2.
2	CHECK DTC. Check the displayed DTC.	Is U0140 a current malfunction?	Go to step 3. Go to step 7.
3	CHECK DTC. 1) Check CAN communication circuit. <Ref. to LAN(diag)-24, CAN Communication Circuit Check.> 2) Read the DTC using Subaru Select Monitor.	Is U0140 a current malfunction?	Go to step 4. Go to step 7.

Diagnostic Procedure with Diagnostic Trouble Code (DTC)

LAN SYSTEM (DIAGNOSTICS)

Step	Check	Yes	No
4 CHECK DTC. Using the Subaru Select Monitor, read DTC of all the systems.	Is the body integrated data no-receive detected in several modules?	Replace the body integrated unit. <Ref. to SL-78, Body Integrated Unit.>	Go to step 5 .
5 REPLACE MODULE. 1) Replace the body integrated unit. 2) Read the DTC using Subaru Select Monitor.	Is U0140 a current malfunction?	Go to step 6 .	System is normal.
6 CHECK MODULE. 1) Reinstall the body integrated unit. 2) Replace the module that the DTC has been detected. 3) Read the DTC using Subaru Select Monitor.	Is U0140 a current malfunction?	Replace the body integrated unit. <Ref. to SL-78, Body Integrated Unit.>	System is normal.
7 CHECK HARNESS. 1) Shake the harness, and check for poor contact. 2) Read the DTC using Subaru Select Monitor.	Is U0140 a current malfunction?	Repair the poor contact of harness, or replace the harness.	Go to step 8 .
8 CHECK CONNECTOR. Check the connector used for high speed CAN for poor contact.	Is there poor contact of connector?	Repair the connector that has poor contact, or replace harness.	It is possible that temporary poor communication occurs. Delete the DTC.

Diagnostic Procedure with Diagnostic Trouble Code (DTC)

LAN SYSTEM (DIAGNOSTICS)

R: DTC U0151 LOST COMMUNICATION WITH RESTRAINTS CONTROL MODULE

DTC DETECTING CONDITION:

No data is received from A/B CM.

TROUBLE SYMPTOM:

Cooperation control with A/B CM does not operate properly.

WIRING DIAGRAM:

CAN communication system <Ref. to WI-46, WIRING DIAGRAM, CAN Communication System.>

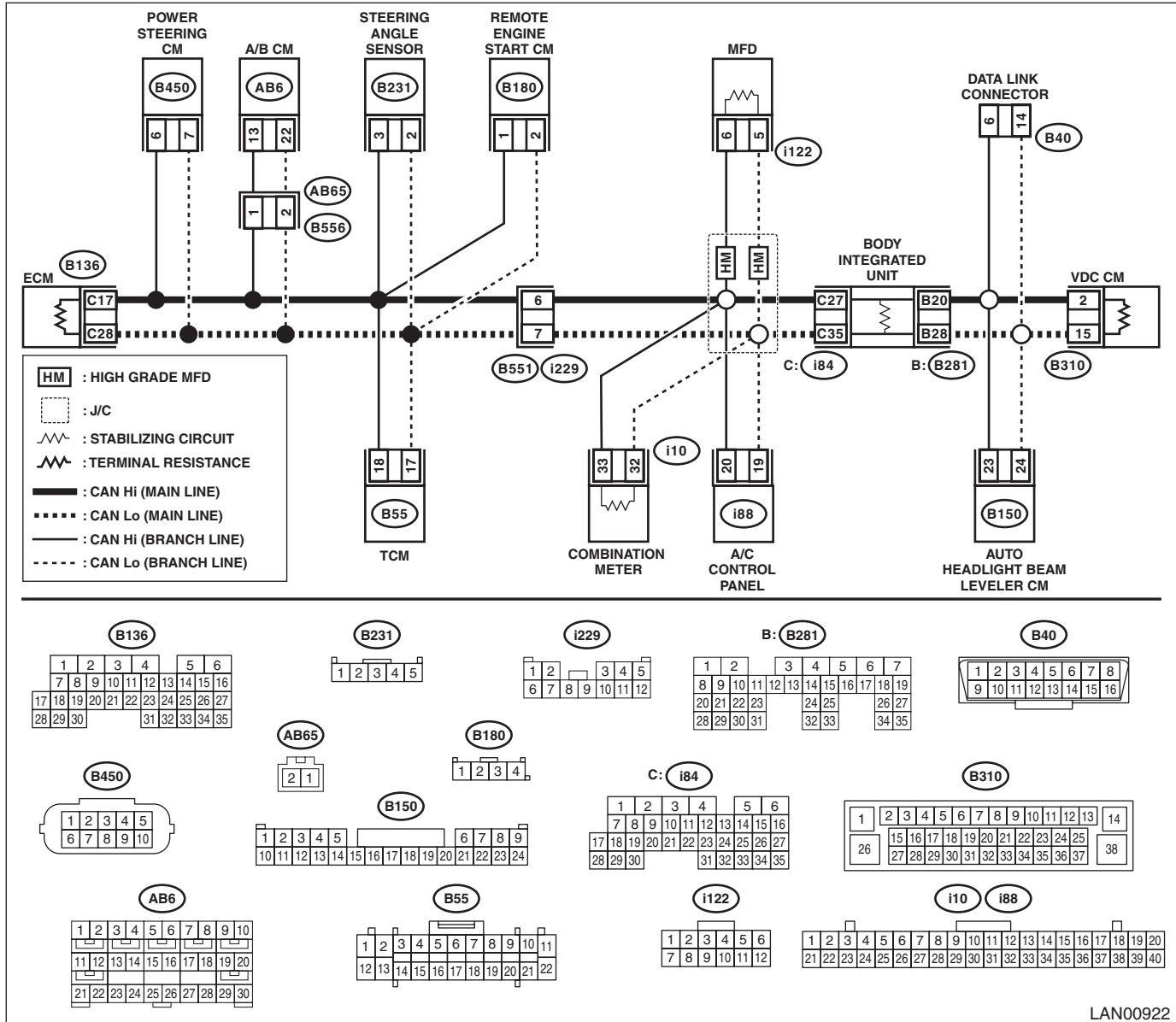

Step	Check	Yes	No
1	CHECK DTC. Check the displayed DTC.	Are DTCs other than U*** displayed?	Perform the diagnosis according to DTC. Go to step 2.
2	CHECK DTC. Check the displayed DTC.	Is U0151 a current malfunction?	Go to step 3. Go to step 7.
3	CHECK DTC. 1) Check CAN communication circuit. <Ref. to LAN(diag)-24, CAN Communication Circuit Check.> 2) Read the DTC using Subaru Select Monitor.	Is U0151 a current malfunction?	Go to step 4. Go to step 7.

Diagnostic Procedure with Diagnostic Trouble Code (DTC)

LAN SYSTEM (DIAGNOSTICS)

Step	Check	Yes	No
4 CHECK DTC. Using the Subaru Select Monitor, read DTC of all the systems.	Is the airbag data no-receive detected in several modules?	Replace the A/B CM. <Ref. to AB-77, Airbag Control Module.>	Go to step 5 .
5 REPLACE MODULE. 1) Replace the A/B CM. 2) Read the DTC using Subaru Select Monitor.	Is U0151 a current malfunction?	Go to step 6 .	System is normal.
6 CHECK MODULE. 1) Reinstall the A/B CM. 2) Replace the module that the DTC has been detected. 3) Read the DTC using Subaru Select Monitor.	Is U0151 a current malfunction?	Replace the A/B CM. <Ref. to AB-77, Airbag Control Module.>	System is normal.
7 CHECK HARNESS. 1) Shake the harness, and check for poor contact. 2) Read the DTC using Subaru Select Monitor.	Is U0151 a current malfunction?	Repair the poor contact of harness, or replace the harness.	Go to step 8 .
8 CHECK CONNECTOR. Check the connector used for high speed CAN for poor contact.	Is there poor contact of connector?	Repair the connector that has poor contact, or replace harness.	It is possible that temporary poor communication occurs. Delete the DTC.

Diagnostic Procedure with Diagnostic Trouble Code (DTC)

LAN SYSTEM (DIAGNOSTICS)

S: DTC U0155 LOST COMMUNICATION WITH INSTRUMENT PANEL CLUSTER (IPC) CONTROL MODULE

DTC DETECTING CONDITION:

No data received from combination meter.

TROUBLE SYMPTOM:

Display of combination meter does not operate properly.

WIRING DIAGRAM:

CAN communication system <Ref. to WI-46, WIRING DIAGRAM, CAN Communication System.>

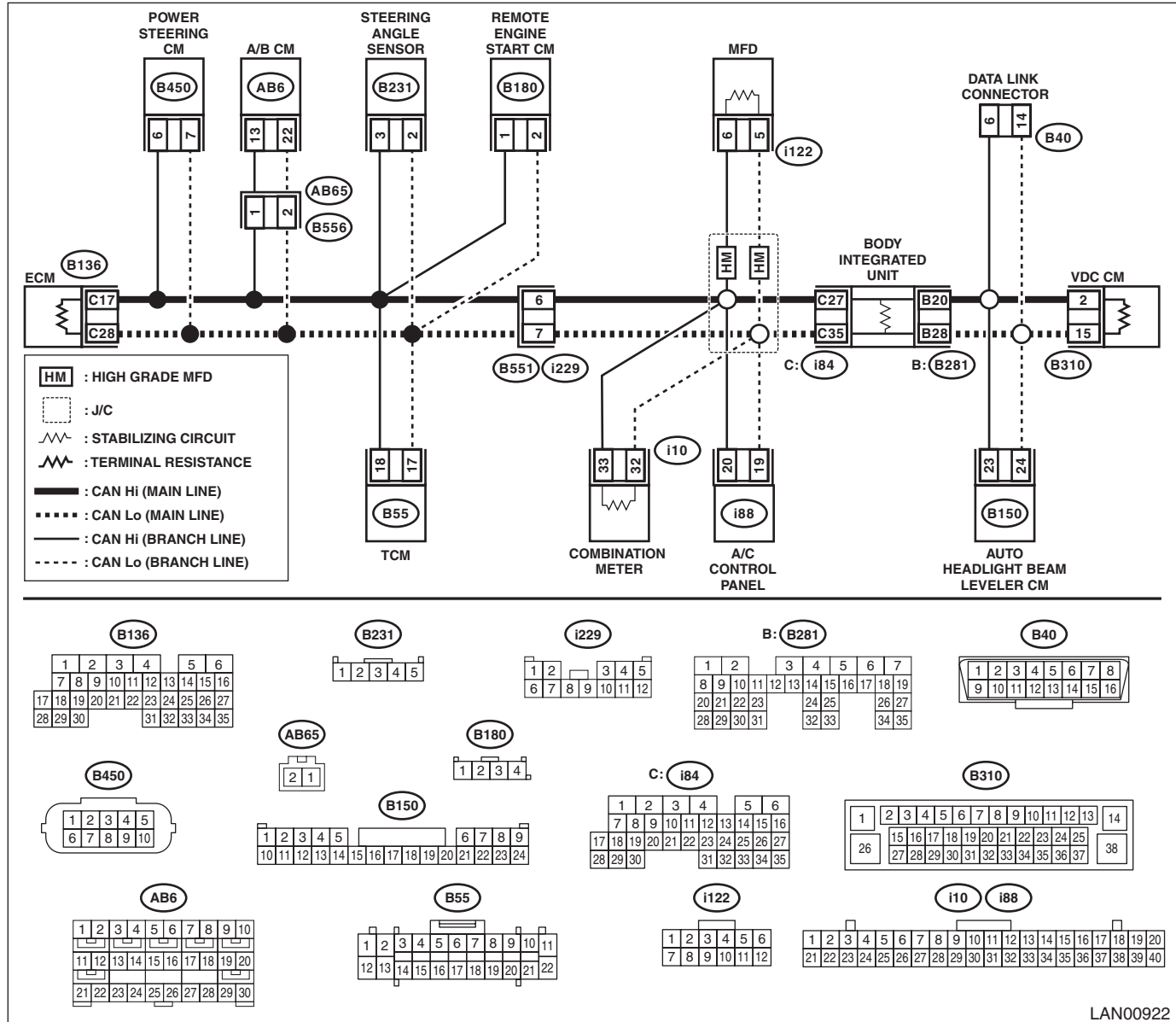

LAN00922

Step	Check	Yes	No	
1	CHECK DTC. Check the displayed DTC.	Are DTCs other than U*** displayed?	Perform the diagnosis according to DTC.	Go to step 2.
2	CHECK DTC. Check the displayed DTC.	Is U0155 a current malfunction?	Go to step 3.	Go to step 7.

Diagnostic Procedure with Diagnostic Trouble Code (DTC)

LAN SYSTEM (DIAGNOSTICS)

Step	Check	Yes	No
3 CHECK DTC. 1) Check CAN communication circuit. <Ref. to LAN(diag)-24, CAN Communication Circuit Check.> 2) Read the DTC using Subaru Select Monitor.	Is U0155 a current malfunction?	Go to step 4.	Go to step 7.
4 CHECK DTC. Using the Subaru Select Monitor, read DTC of all the systems.	Is the meter data no-receive detected in several modules?	Replace the meter. <Ref. to IDI-17, Combination Meter.>	Go to step 5.
5 REPLACE MODULE. 1) Replace the combination meter. 2) Read the DTC using Subaru Select Monitor.	Is U0155 a current malfunction?	Go to step 6.	System is normal.
6 CHECK MODULE. 1) Replace the current combination meter with the original combination meter. 2) Replace the module that the DTC has been detected. 3) Read the DTC using Subaru Select Monitor.	Is U0155 a current malfunction?	Replace the combination meter. <Ref. to IDI-17, Combination Meter.>	System is normal.
7 CHECK HARNESS. 1) Shake the harness, and check for poor contact. 2) Read the DTC using Subaru Select Monitor.	Is U0155 a current malfunction?	Repair the poor contact of harness, or replace the harness.	Go to step 8.
8 CHECK CONNECTOR. Check the connector used for high speed CAN for poor contact.	Is there poor contact of connector?	Repair the connector that has poor contact, or replace harness.	It is possible that temporary poor communication occurs. Delete the DTC.

Diagnostic Procedure with Diagnostic Trouble Code (DTC)

LAN SYSTEM (DIAGNOSTICS)

T: DTC U0164 LOST COMMUNICATION WITH HVAC CONTROL MODULE

DTC DETECTING CONDITION:

No data is received from A/C control panel.

TROUBLE SYMPTOM:

Cooperation control of air conditioner does not operate properly.

WIRING DIAGRAM:

CAN communication system <Ref. to WI-46, WIRING DIAGRAM, CAN Communication System.>

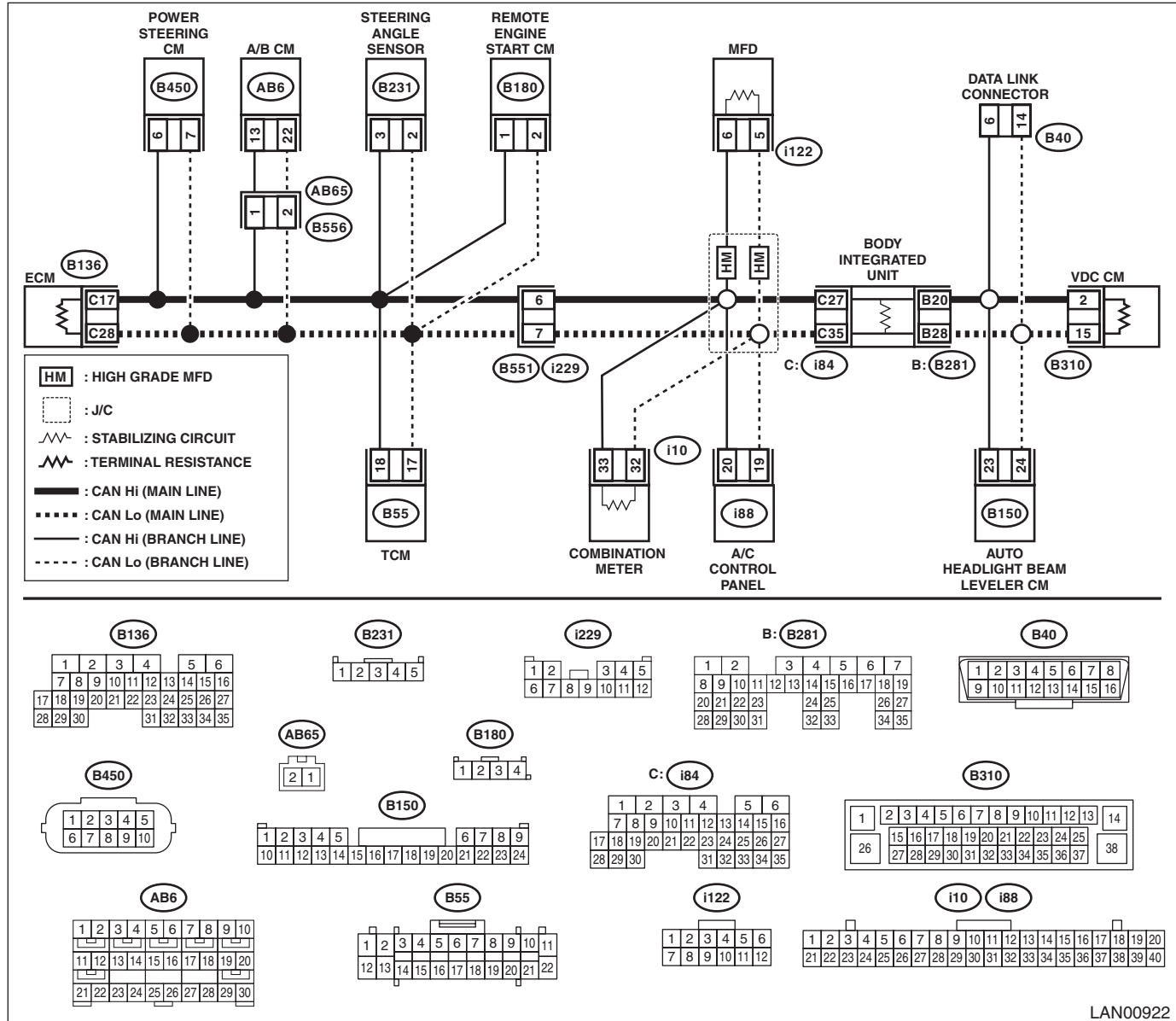

LAN00922

Step	Check	Yes	No
1	CHECK DTC. Check the displayed DTC.	Are DTCs other than U*** displayed?	Perform the diagnosis according to DTC. Go to step 2.
2	CHECK DTC. Check the displayed DTC.	Is U0164 a current malfunction?	Go to step 3. Go to step 7.
3	CHECK DTC. 1) Check CAN communication circuit. <Ref. to LAN(diag)-24, CAN Communication Circuit Check.> 2) Read the DTC using Subaru Select Monitor.	Is U0164 a current malfunction?	Go to step 4. Go to step 7.

Diagnostic Procedure with Diagnostic Trouble Code (DTC)

LAN SYSTEM (DIAGNOSTICS)

Step	Check	Yes	No
4 CHECK DTC. Using the Subaru Select Monitor, read DTC of all the systems.	Is the air conditioner data no-receive detected in several modules?	Replace the A/C control panel.	Go to step 5.
5 REPLACE MODULE. 1) Replace the A/C control panel. 2) Read the DTC using Subaru Select Monitor.	Is U0164 a current malfunction?	Go to step 6.	System is normal.
6 CHECK MODULE. 1) Restore the A/C control panel. 2) Replace the module that the DTC has been detected. 3) Read the DTC using Subaru Select Monitor.	Is U0164 a current malfunction?	Replace the A/C control panel.	System is normal.
7 CHECK HARNESS. 1) Shake the harness, and check for poor contact. 2) Read the DTC using Subaru Select Monitor.	Is U0164 a current malfunction?	Repair the poor contact of harness, or replace the harness.	Go to step 8.
8 CHECK CONNECTOR. Check the connector used for high speed CAN for poor contact.	Is there poor contact of connector?	Repair the connector that has poor contact, or replace harness.	It is possible that temporary poor communication occurs. Delete the DTC.

U: DTC U1120 LOST COMMUNICATION WITH AUTOSTART STOP CONTROL MODULE

NOTE:

The electric power steering CM identifies whether the auto start stop function is provided or not using information from the combination meter. Therefore, this DTC may be detected if lost communication with the combination meter occurs.

For the diagnostic procedure, refer to DTC U0155 LOST COMMUNICATION WITH INSTRUMENT PANEL CLUSTER (IPC) CONTROL MODULE. <Ref. to LAN(diag)-121, DTC U0155 LOST COMMUNICATION WITH INSTRUMENT PANEL CLUSTER (IPC) CONTROL MODULE, Diagnostic Procedure with Diagnostic Trouble Code (DTC).>