

Drain Separator

EMISSION CONTROL (AUX. EMISSION CONTROL DEVICES)

12. Drain Separator

A: REMOVAL

The drain separator is installed to the leak check valve assembly. Refer to “Leak Check Valve Assembly” for removal procedure. <Ref. to EC(H4DO)-35, REMOVAL, Leak Check Valve Assembly.>

B: INSTALLATION

The drain separator is installed to the leak check valve assembly. Refer to “Leak Check Valve Assembly” for installation procedure. <Ref. to EC(H4DO)-40, INSTALLATION, Leak Check Valve Assembly.>

C: DISASSEMBLY

1) Lift up the claw of the drain separator, and slide the drain separator in the direction of the arrow (A) to remove the drain separator.

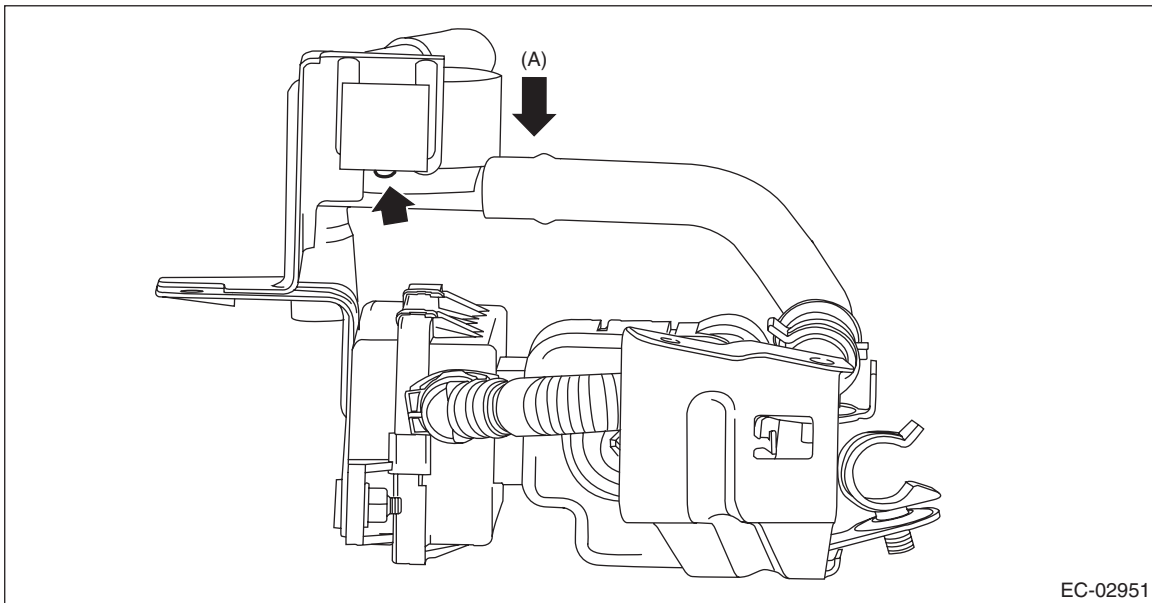

2) Remove the drain hose and drain tube from the drain separator.

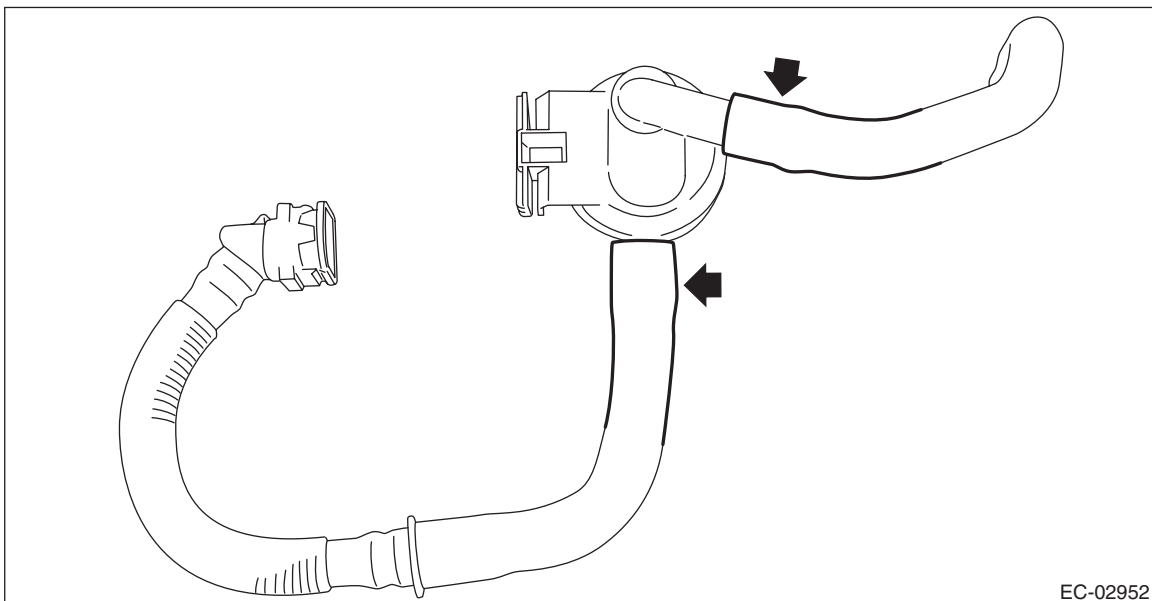

D: ASSEMBLY

Assemble in the reverse order of disassembly.

Drain Separator

EMISSION CONTROL (AUX. EMISSION CONTROL DEVICES)

E: INSPECTION

- 1) Check that the drain separator and drain separator bracket have no deformation, crack, or other damage.
- 2) Check that the drain hose and drain tube have no crack, damage, or looseness.
- 3) Check that no foreign substances are clogged in the drain separator.