

# General Description

INTAKE (INDUCTION)

## 1. General Description

### A: COMPONENT

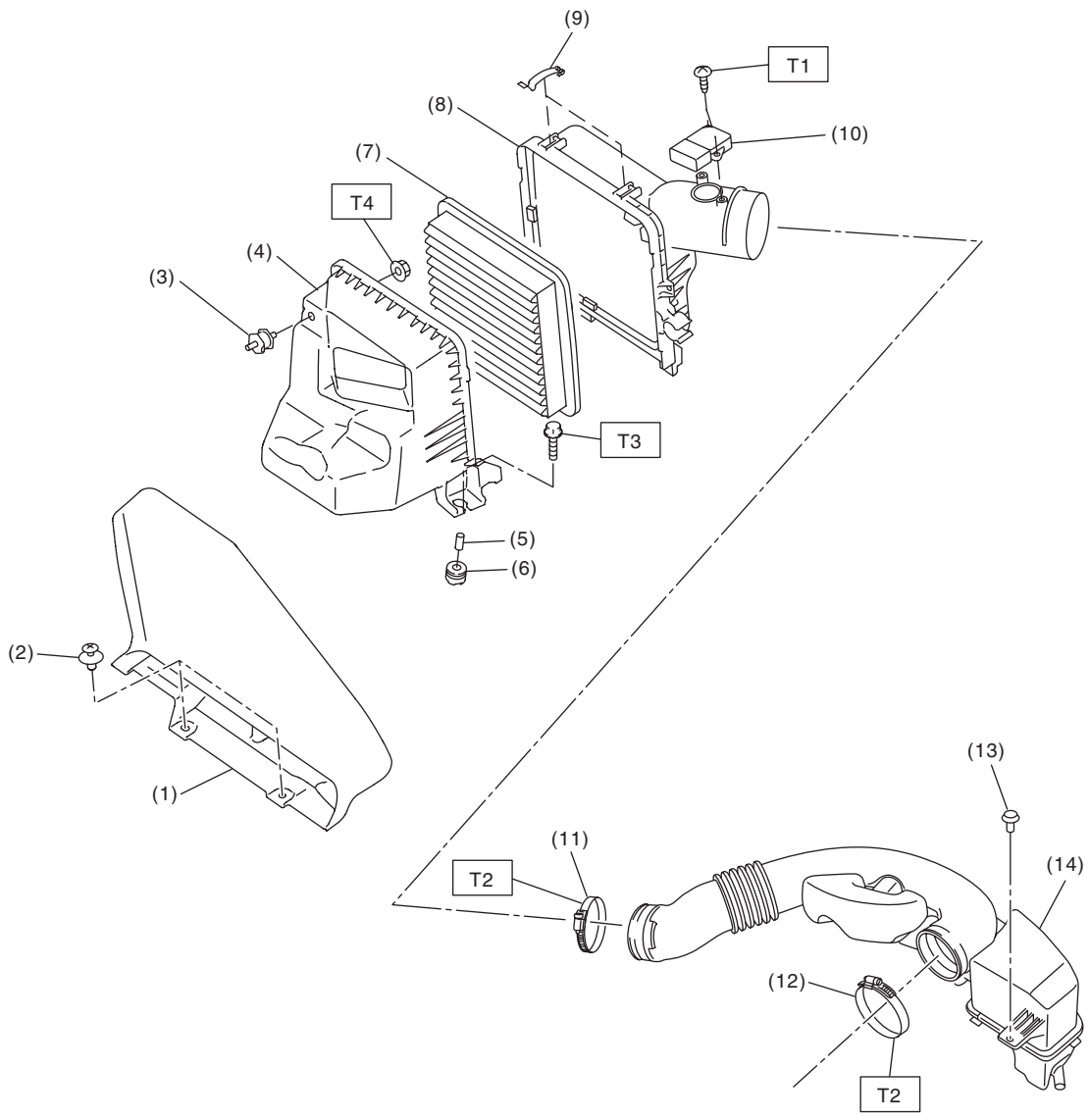

IN-03058

IN(H4DO)-2

# General Description

INTAKE (INDUCTION)

---

(1) Air intake duct	(8) Air cleaner case (rear)	<b>Tightening torque: N·m (kgf-m, ft-lb)</b> <b>T1: 1 (0.1, 0.7)</b> <b>T2: 3 (0.3, 2.2)</b> <b>T3: 6 (0.6, 4.4)</b> <b>T4: 7.5 (0.8, 5.5)</b>
(2) Clip	(9) Clip	
(3) Cushion	(10) Mass air flow and intake air temperature sensor	
(4) Air cleaner case (front)	(11) Clamp	
(5) Spacer	(12) Clamp	
(6) Cushion	(13) Clip	
(7) Air cleaner element	(14) Air intake boot	

---

## B: CAUTION

- Prior to starting work, pay special attention to the following:
  1. Always wear work clothes, a safety cap, protective shoes. Additionally, wear a helmet, protective goggles, etc. if necessary.
  2. Protect the vehicle using a seat cover, fender cover, etc.
  3. Prepare the service tools, clean cloth, containers to catch grease and oil, etc.
- Vehicle components are extremely hot immediately after driving. Be wary of receiving burns from heated parts.
- When performing a repair, identify the cause of trouble and avoid unnecessary removal, disassembly and replacement.
- Before disconnecting connectors of sensors or units, be sure to disconnect the ground cable from battery.
- Always use the jack-up point when the shop jacks or rigid racks are used to support the vehicle.
- Remove contamination including dirt and corrosion before removal, installation, disassembly or assembly.
- Keep the removed parts in order and protect them from dust and dirt.
- All removed parts, if to be reused, should be reinstalled in the original positions with attention to the correct directions, etc.
- Bolts, nuts and washers should be replaced with new parts as required.
- Be sure to tighten the fasteners including bolts and nuts to the specified torque.