

37.Rearview Camera System

A: WIRING DIAGRAM

1. SEDAN MODEL (WITHOUT NAVIGATION SYSTEM)

RVCAM(S)-01

RVCAM(S)-01

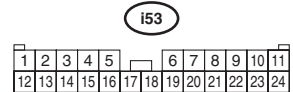
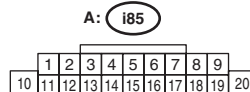
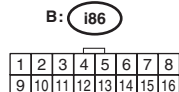
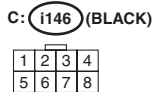
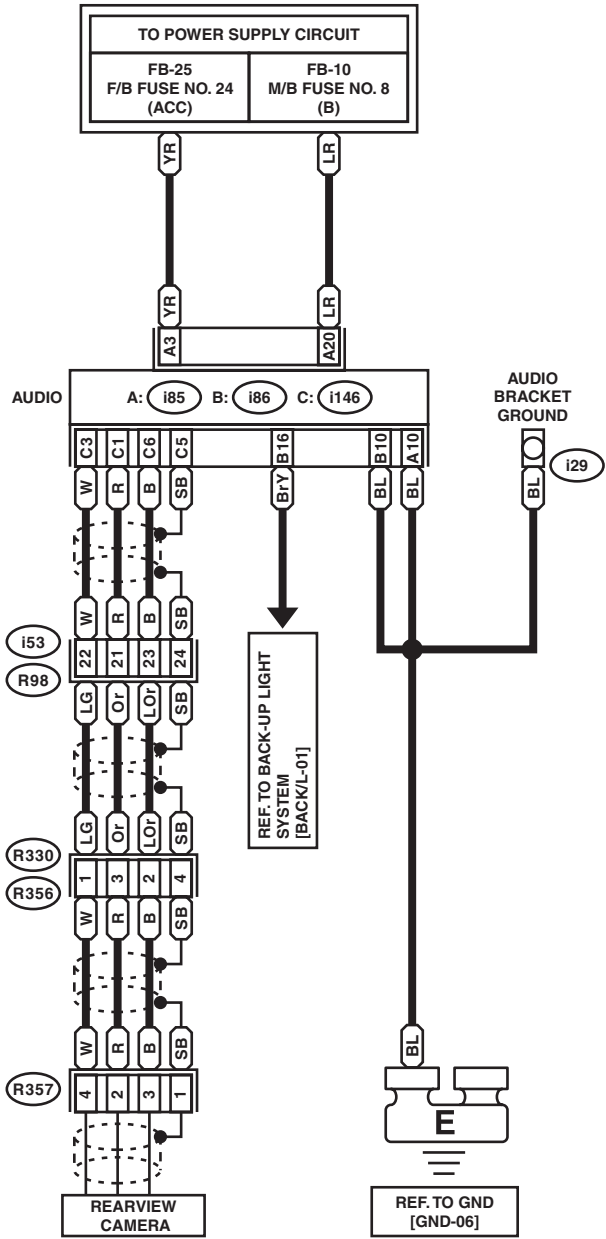

Rearview Camera System

WIRING SYSTEM

2. SEDAN MODEL (WITH NAVIGATION SYSTEM)

- Standard MFD

RVCAM(SN)-01

RVCAM(SN)-01

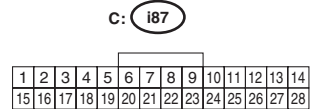
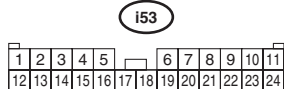
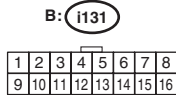
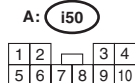
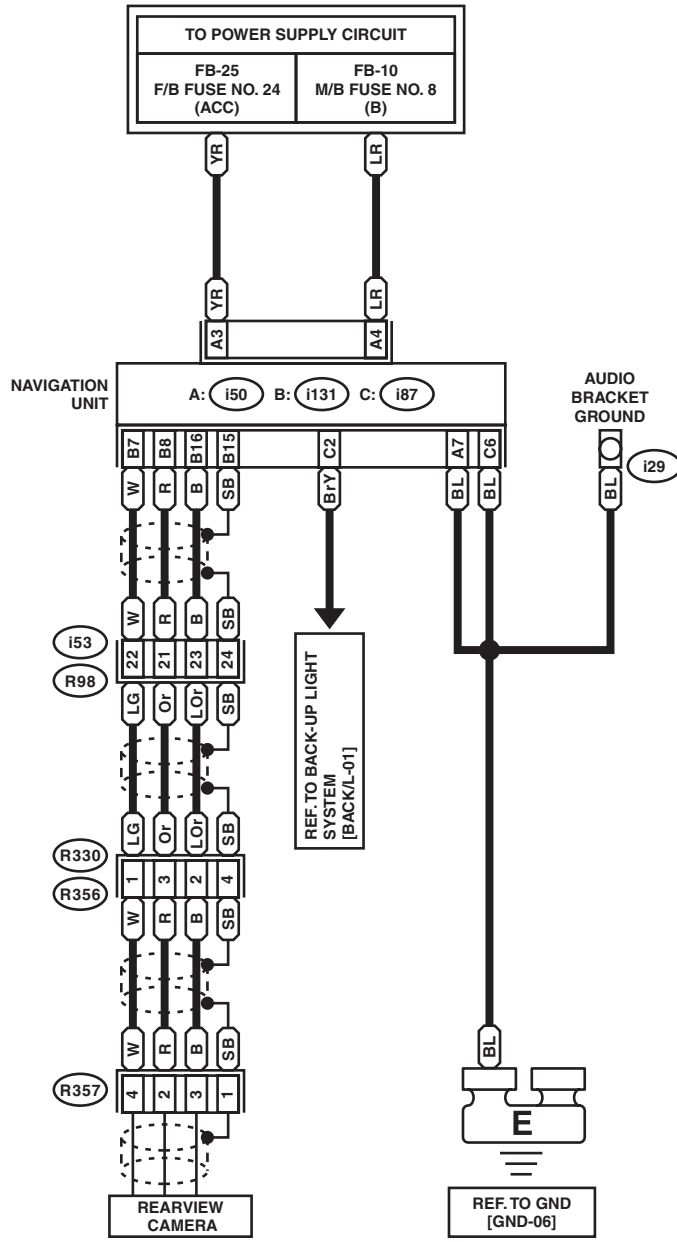

WI-37854

Rearview Camera System

WIRING SYSTEM

- High grade MFD

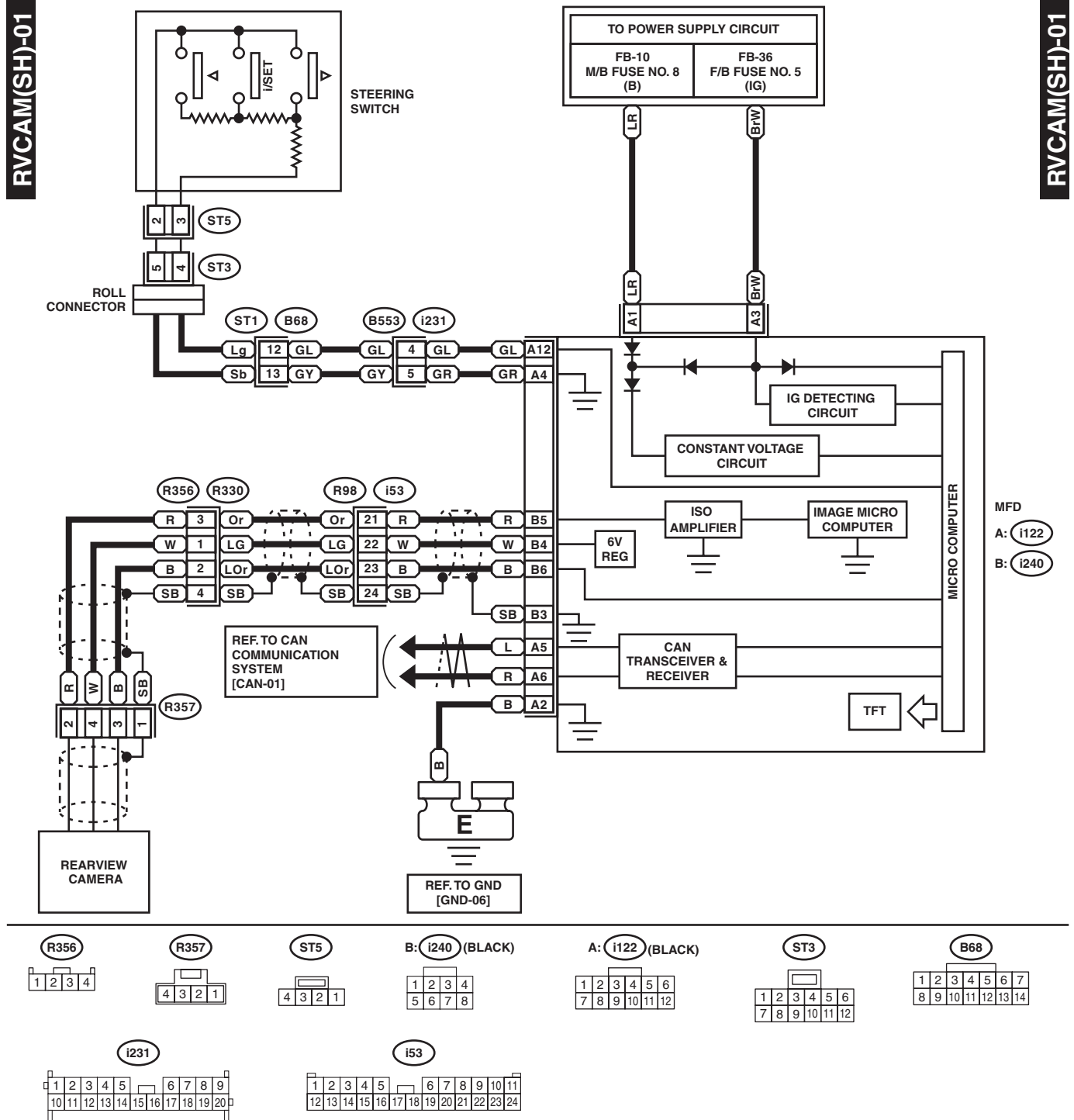

WI-37855

Rearview Camera System

WIRING SYSTEM

3. WAGON MODEL (WITHOUT NAVIGATION SYSTEM)

RVCAM(W)-01

RVCAM(W)-01

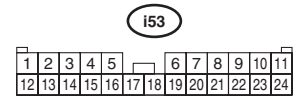
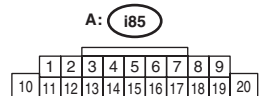
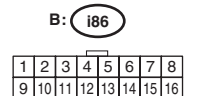
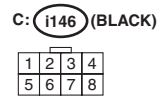
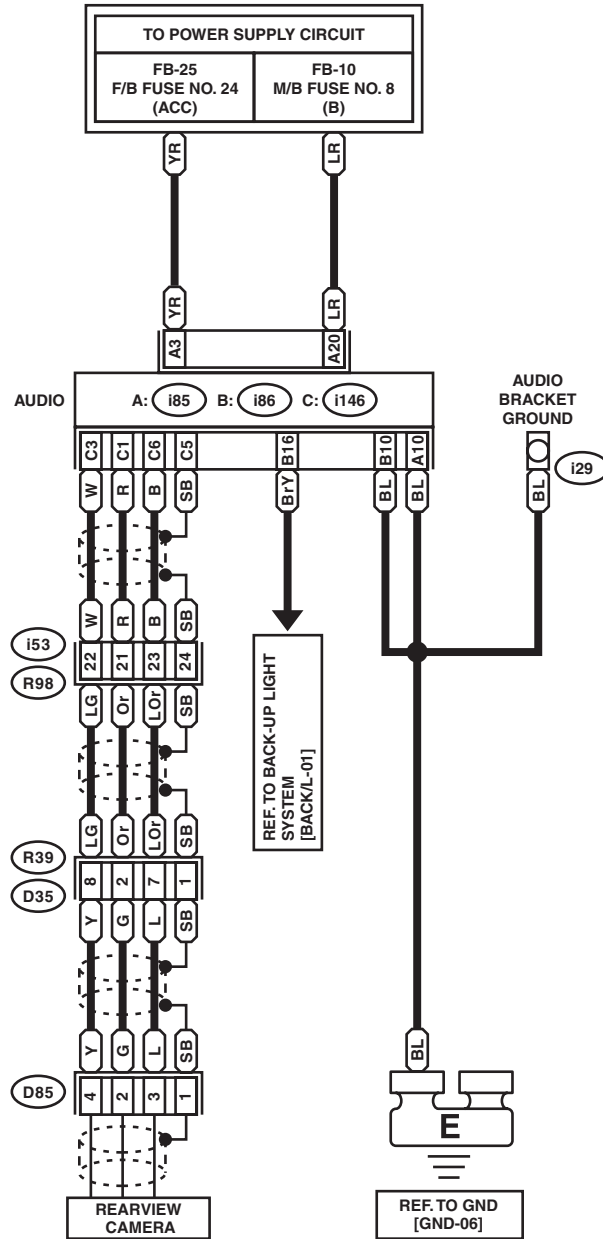

WI-37856

4. WAGON MODEL (WITH NAVIGATION SYSTEM)

- Standard MFD

RVCAM(WN)-01

RVCAM(WN)-01

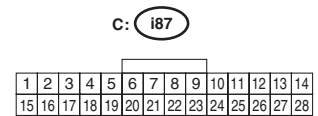
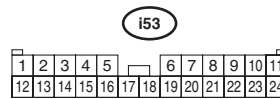
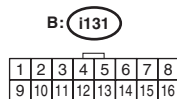
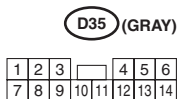
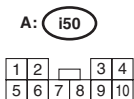
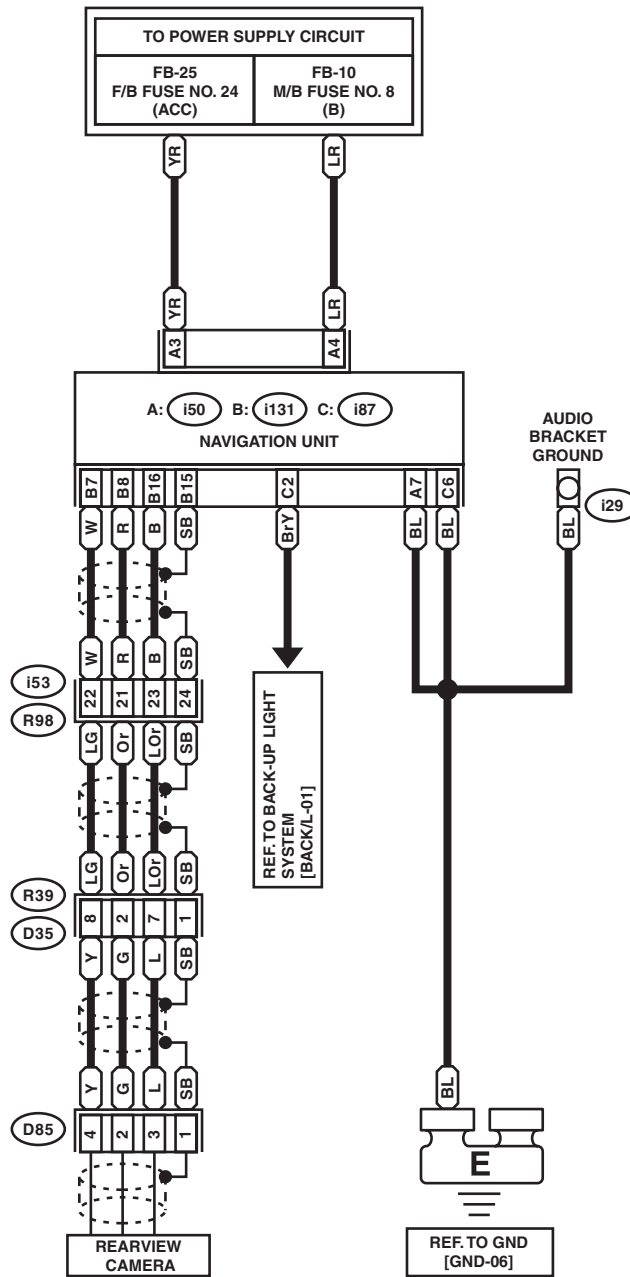

WI-37857

Rearview Camera System

WIRING SYSTEM

- High grade MFD

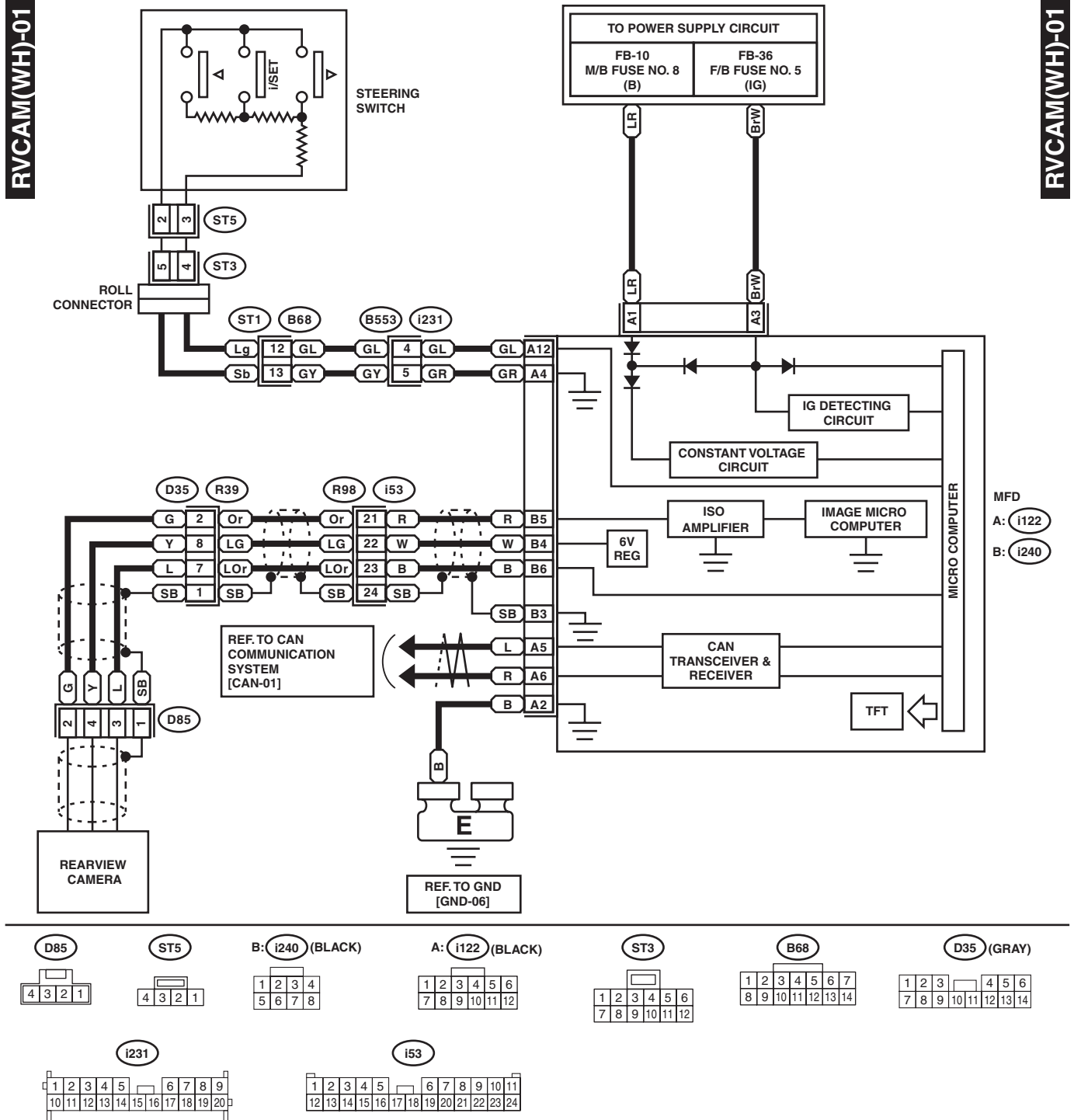

WI-37858