

Chain Cover

MECHANICAL

14.Chain Cover

A: REMOVAL

NOTE:

When replacing a single part, perform the work with the engine assembly installed to body.

1) When working on the vehicle

NOTE:

When working on the vehicle, perform the following steps also.

- (1) Remove the radiator. <Ref. to CO(H4DO)-32, REMOVAL, Radiator.>
- (2) Remove the front exhaust pipe. <Ref. to EX(H4DO)-7, REMOVAL, Front Exhaust Pipe.>
- (3) Remove the bolts which secure the generator cord stay to the chain cover.

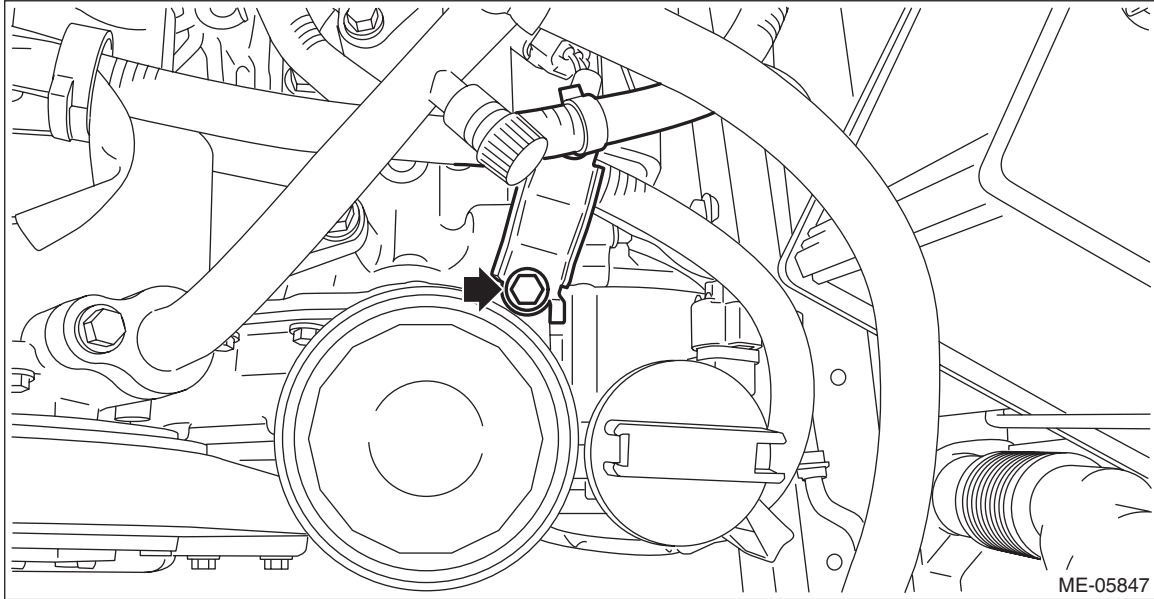

2) Remove the generator bracket.

- (1) Remove the V-belts. <Ref. to ME(H4DO)-75, REMOVAL, V-belt.>
- (2) Remove the generator. <Ref. to SC(H4DO)-35, REMOVAL, Generator.>
- (3) Remove the generator bracket from the engine.

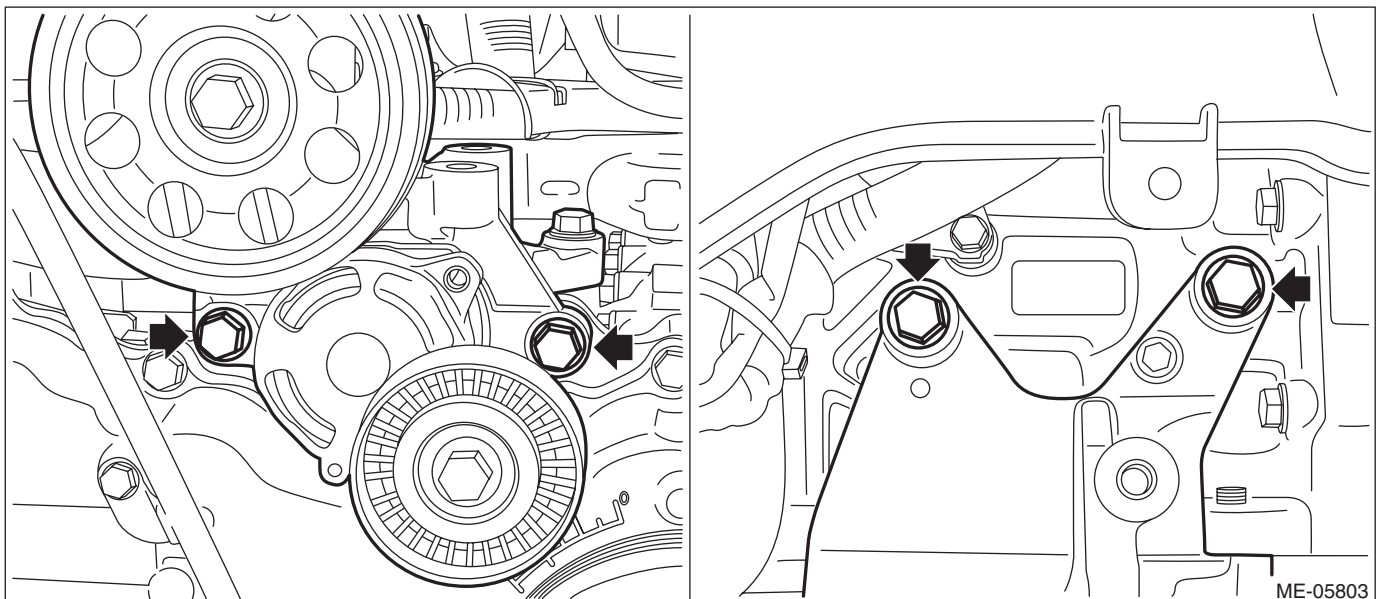

3) Drain the engine oil. <Ref. to LU(H4DO)-10, REPLACEMENT, Engine Oil.>

4) Remove the water pump pulley. <Ref. to CO(H4DO)-17, WATER PUMP, REMOVAL, Water Pump.>

Chain Cover

MECHANICAL

5) Remove the crank pulley. <Ref. to ME(H4DO)-83, REMOVAL, Crank Pulley.>

6) Disconnect the connector (A) from the exhaust camshaft position sensor RH, and remove the engine harness stay from the chain cover.

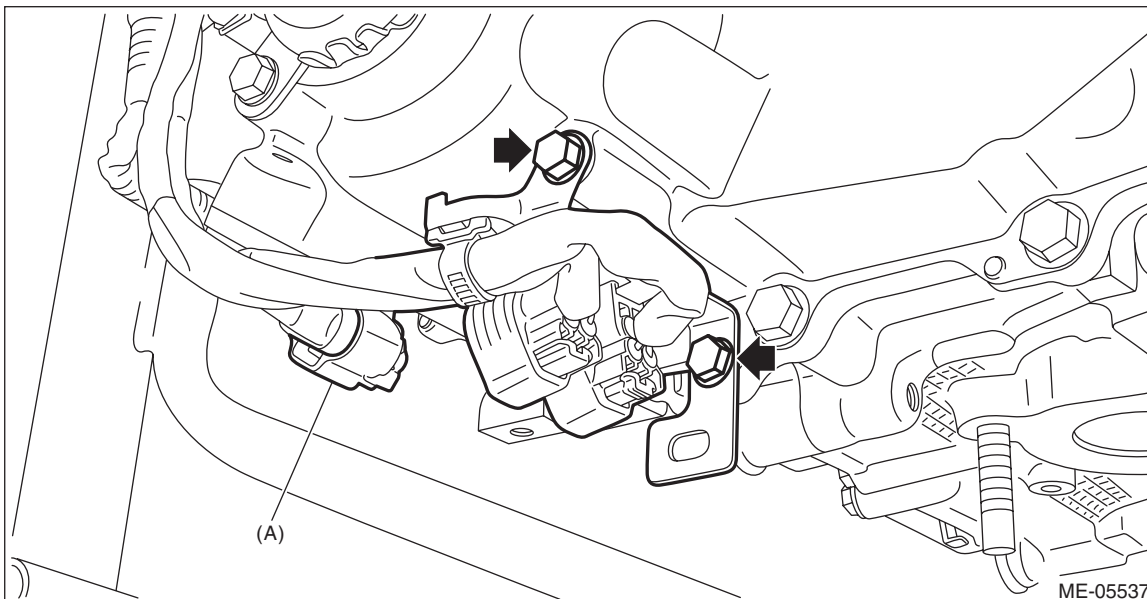

7) Disconnect the connector (A) from the intake oil control solenoid RH, connector (B) from the exhaust oil control solenoid RH, and the connector (C) from the intake camshaft position sensor RH, and then remove the clips (D) and (E) which secure the engine harness.

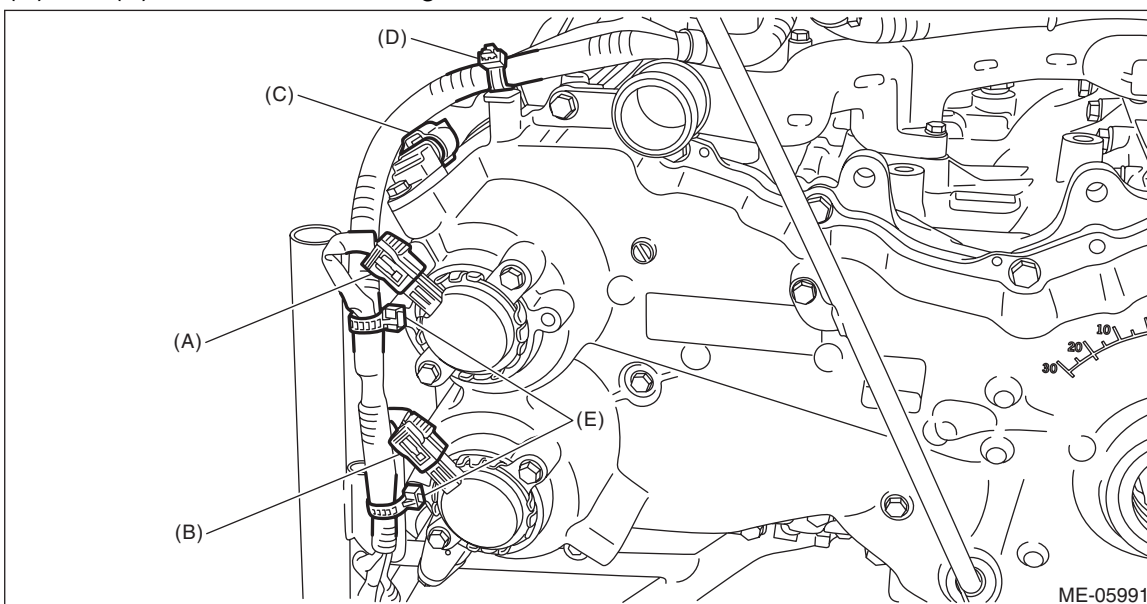

Chain Cover

MECHANICAL

8) Disconnect the connectors from the oil level switch, and remove the clip (A) which secure the oil level switch harness.

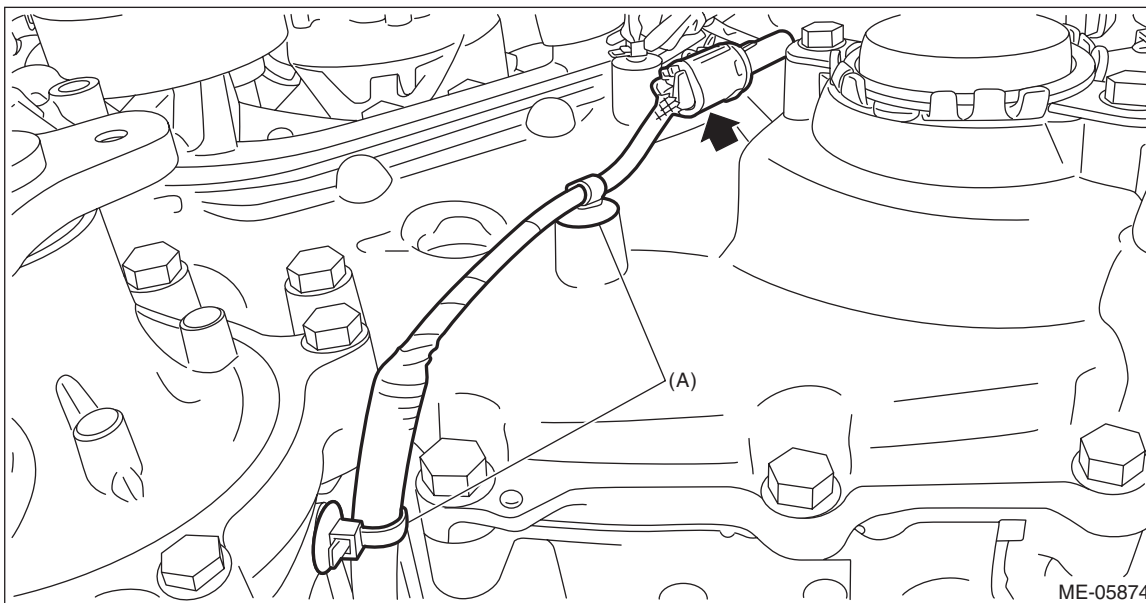

9) Remove the rubber cap from the oil pressure switch.

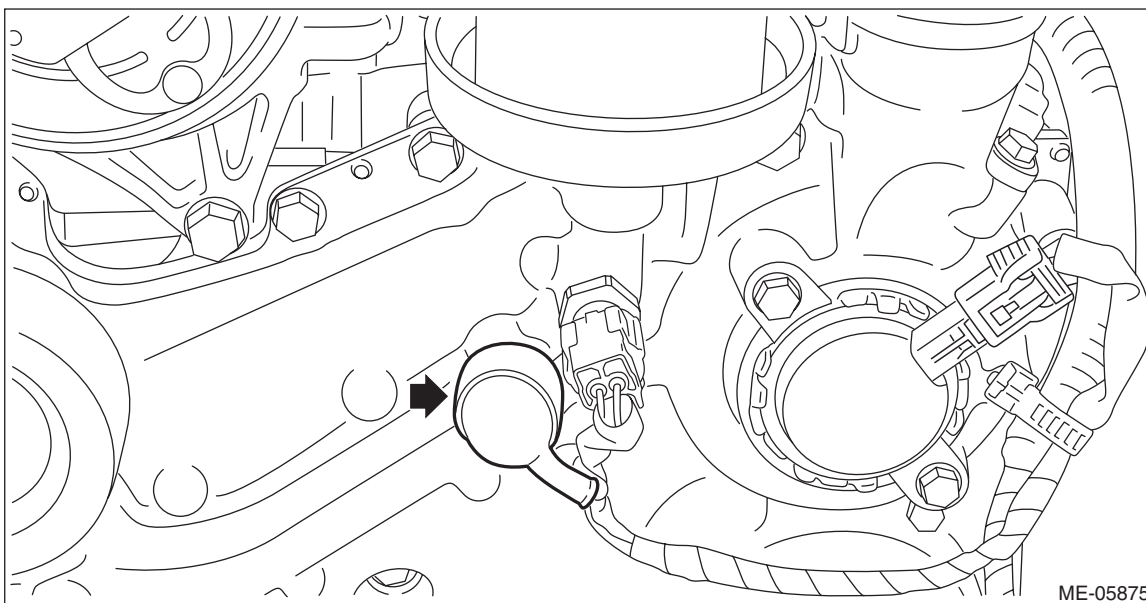

Chain Cover

MECHANICAL

10) Disconnect the terminal (A) from the oil pressure switch, connector (B) from the engine oil temperature sensor, connector (C) from the intake oil control solenoid LH, connector (D) from the exhaust oil control solenoid LH, connector (E) from the intake camshaft position sensor LH, and connector (F) from the exhaust camshaft position sensor LH, and remove the clips (G) and (H) which secure the engine harness.

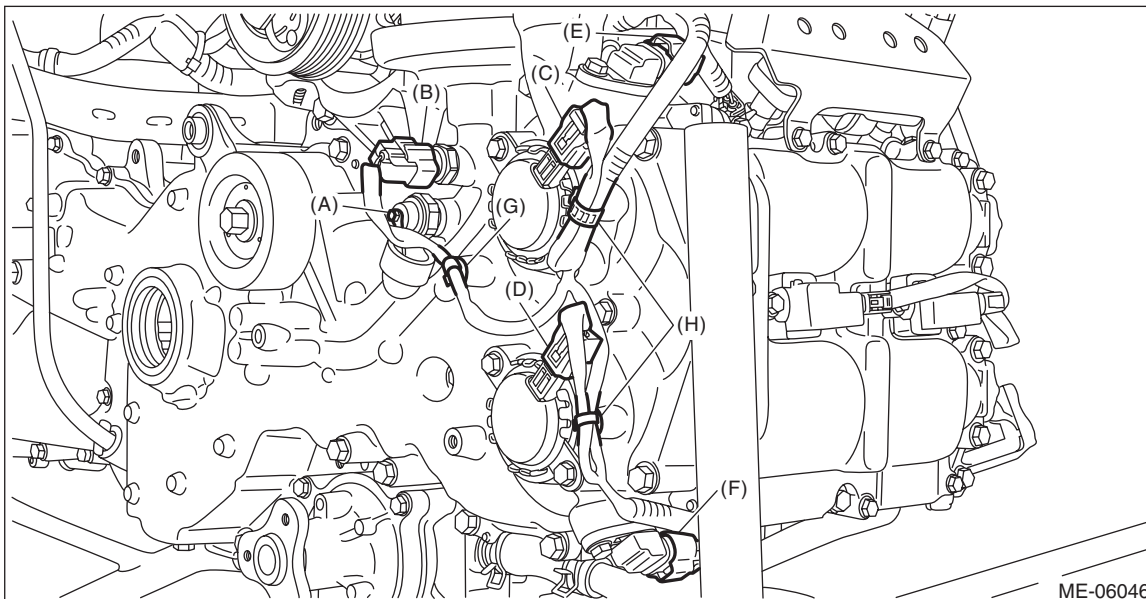

11) Pull out the oil level gauge (A), and remove the oil level gauge guide (B) and idler pulley (C).

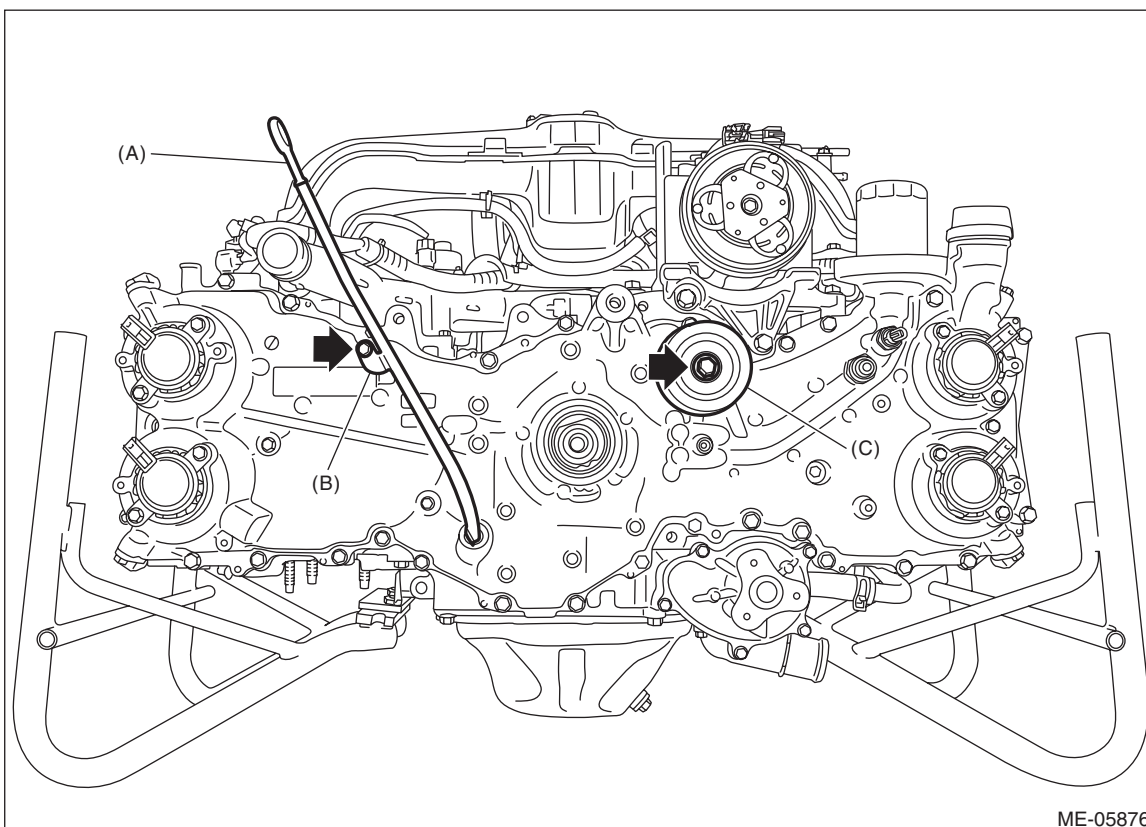

Chain Cover

MECHANICAL

12) Remove the chain cover.

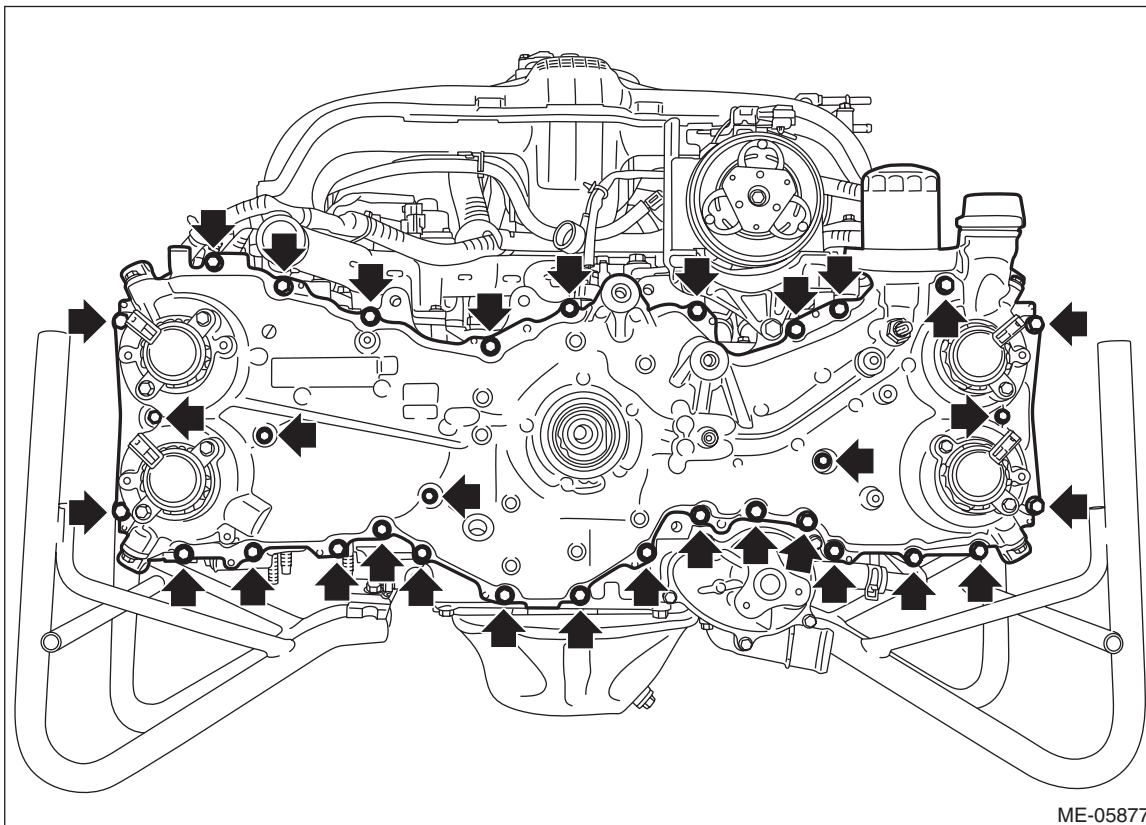

13) Remove the O-rings from cylinder head RH, cylinder head LH, cylinder block LH and oil pan upper.

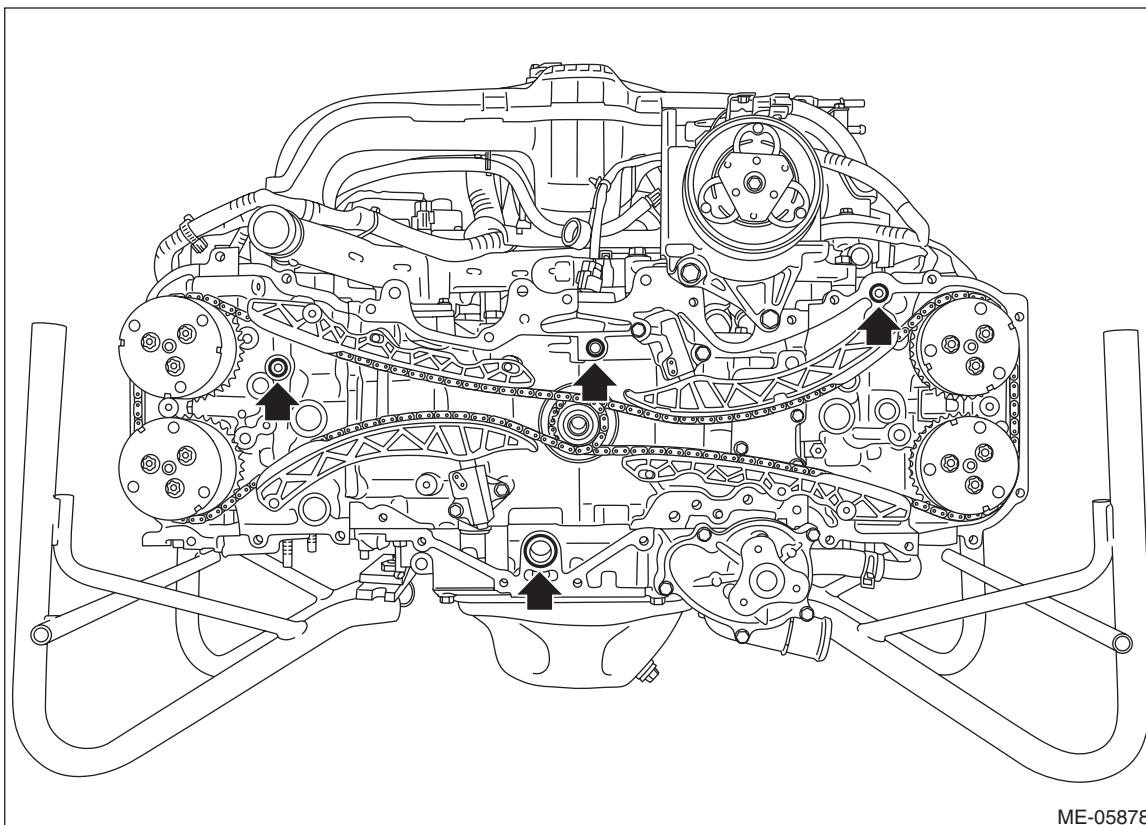

14) Remove the liquid gasket from the chain cover and engine unit.

B: INSTALLATION

1) Install the O-rings to cylinder head RH, cylinder head LH, cylinder block LH and oil pan upper.

NOTE:

- Use new O-rings.
- Apply a coat of engine oil to the O-rings.

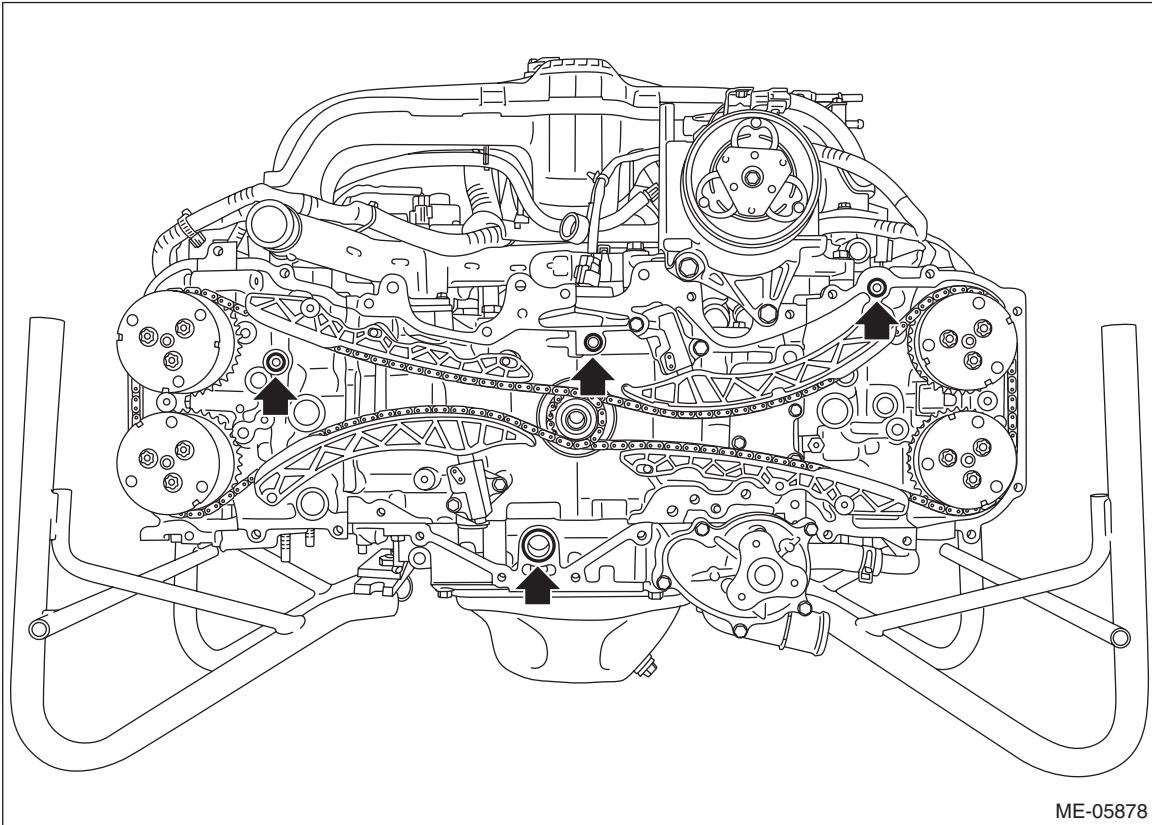

ME-05878

Chain Cover

MECHANICAL

2) Apply liquid gasket if there are gaps between front camshaft cap and cam carrier (A), between cam carrier and cylinder head (B), and between cylinder head and cylinder block (C) as shown.

Liquid gasket:

THREE BOND 1217G (Part No. K0877Y0100) or equivalent

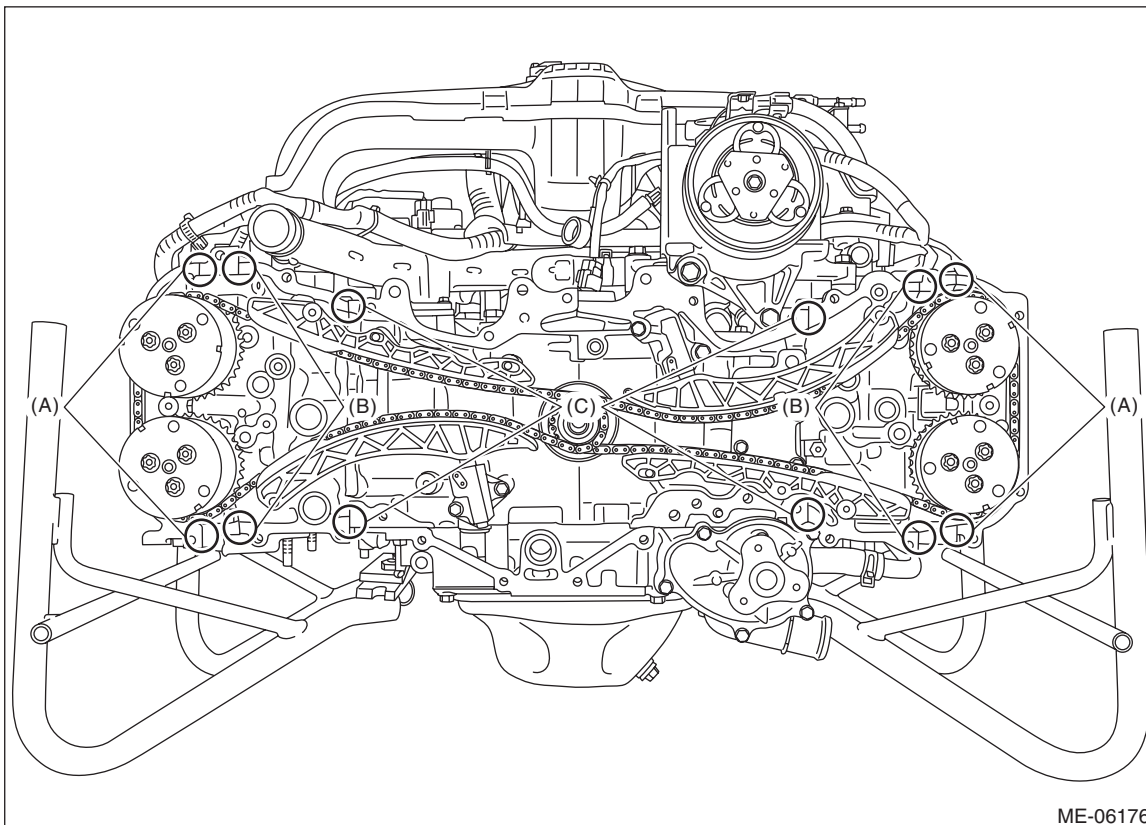

3) Apply liquid gasket to the chain cover mating surface and center boss (5 places) as shown in the figure.

NOTE:

- Before applying liquid gasket, degrease the old liquid gasket seal surface of the engine and chain cover.
- Install within 5 min. after applying liquid gasket.

Liquid gasket:

THREE BOND 1217G (Part No. K0877Y0100) or equivalent

Liquid gasket applying diameter:

4±0.5 mm (0.1575±0.0197 in)

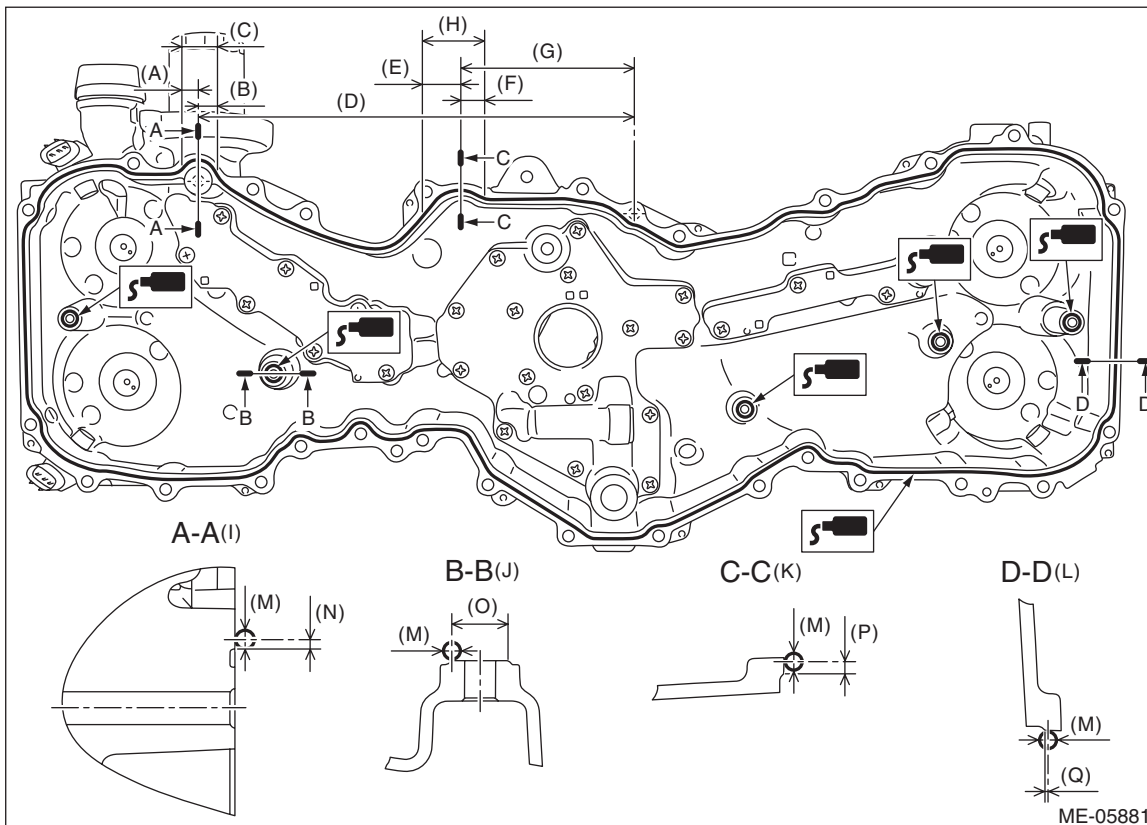

(A) 14.5 mm (0.5709 in)	(G) 127 mm (5.0000 in)	(M) $\phi 4 \pm 0.5$ mm (0.1575±0.0197 in)
(B) 17.5 mm (0.6890 in)	(H) Range B	(N) 2 mm (0.0787 in)
(C) Range A	(I) Liquid gasket applying position of mating surfaces of range A	(O) $\phi 12$ mm (0.4724 in)
(D) 316.2 mm (12.4488 in)	(J) Liquid gasket applying position of center boss (5 places)	(P) 2.5 mm (0.0984 in)
(E) 24.5 mm (0.9646 in)	(K) Liquid gasket applying position of mating surfaces of range B	(Q) 0.5 mm (0.0197 in)
(F) 18.5 mm (0.7283 in)	(L) Liquid gasket applying position of mating surfaces other than range A and range B	

Chain Cover

MECHANICAL

4) Set the chain cover, and tighten the bolts in numerical order as shown in the figure.

Tightening torque:

T1: 10 N·m (1.0 kgf·m, 7.4 ft·lb)

T2: 25 N·m (2.5 kgf·m, 18.4 ft·lb)

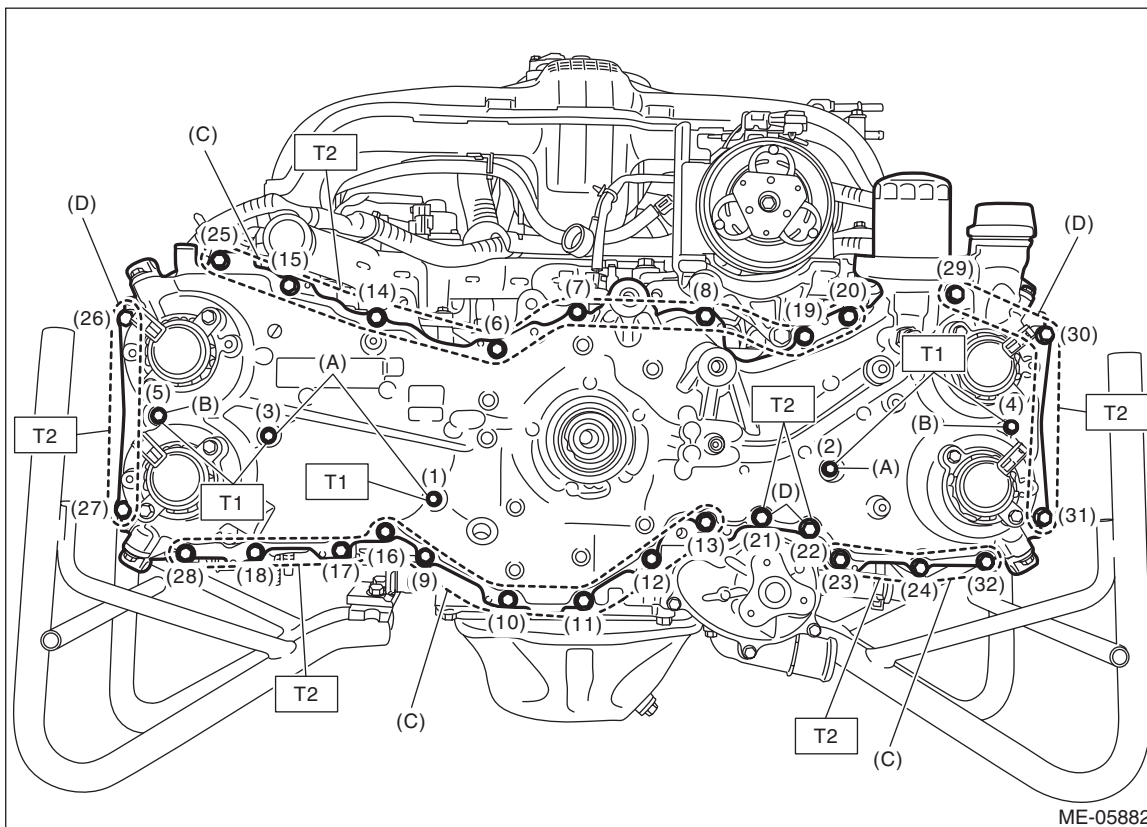

(A) M6 × 20

(C) M8 × 25

(D) M8 × 60

(B) M6 × 50

5) Install the idler pulley (C) and oil level gauge guide (B), and insert the oil level gauge (A).

NOTE:

- Use a new O-ring to the oil level gauge guide.
- Apply a light coat of engine oil to the O-rings of the oil level gauge guide and the oil level gauge.

Tightening torque:

T1: 6.4 N·m (0.7 kgf-m, 4.7 ft-lb)

T2: 36 N·m (3.7 kgf-m, 26.6 ft-lb)

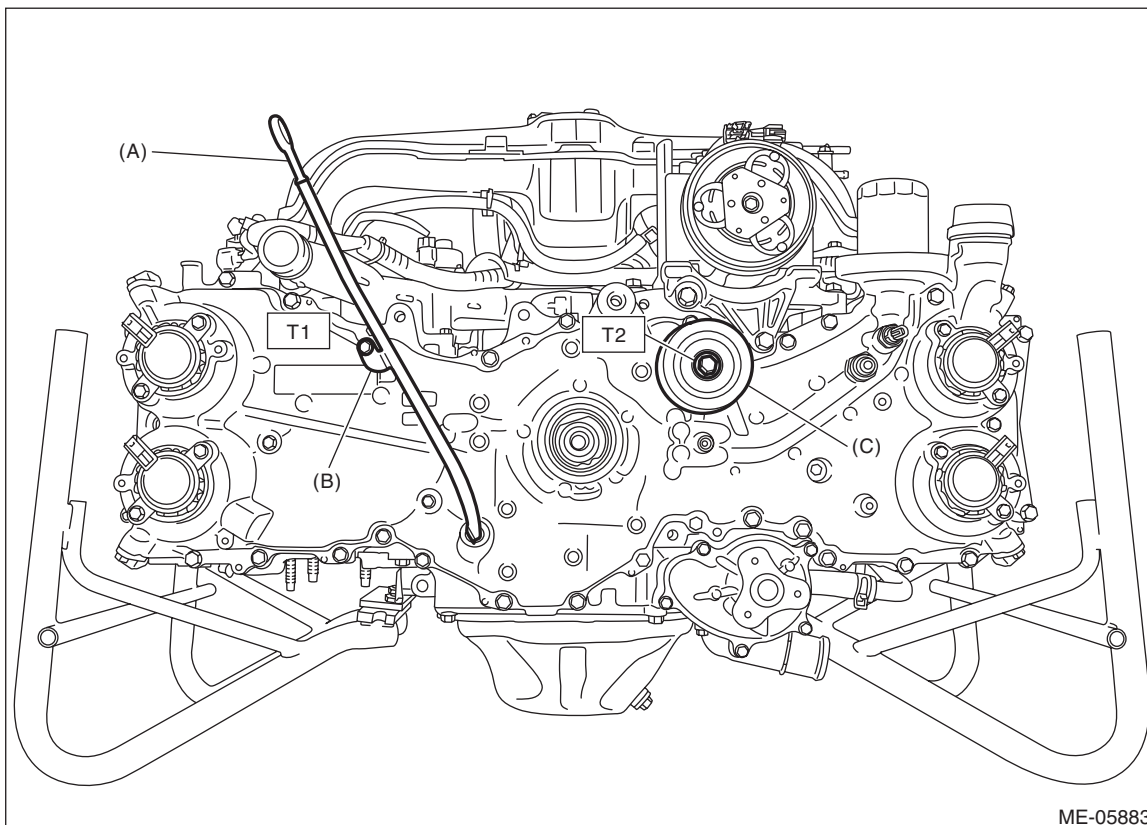

ME-05883

Chain Cover

MECHANICAL

6) Connect the terminal (A) to the oil pressure switch, connector (B) to the engine oil temperature sensor, connector (C) to the intake oil control solenoid LH, connector (D) to the exhaust oil control solenoid LH, connector (E) to the intake camshaft position sensor LH, and connector (F) to the exhaust camshaft position sensor LH, and secure the engine harness with the clips (G) and (H).

NOTE:

The oil pressure switch harness must be positioned toward the left lower side of the vehicle within the range of 90°.

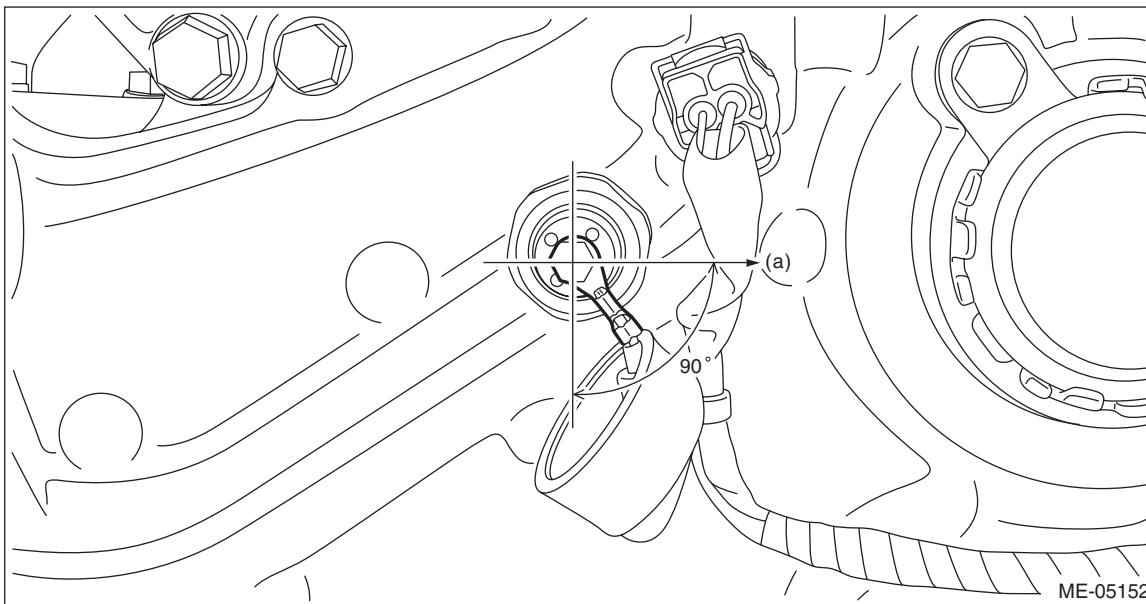

(a) Left side of vehicle

Tightening torque:

1.5 N·m (0.2 kgf·m, 1.1 ft·lb)

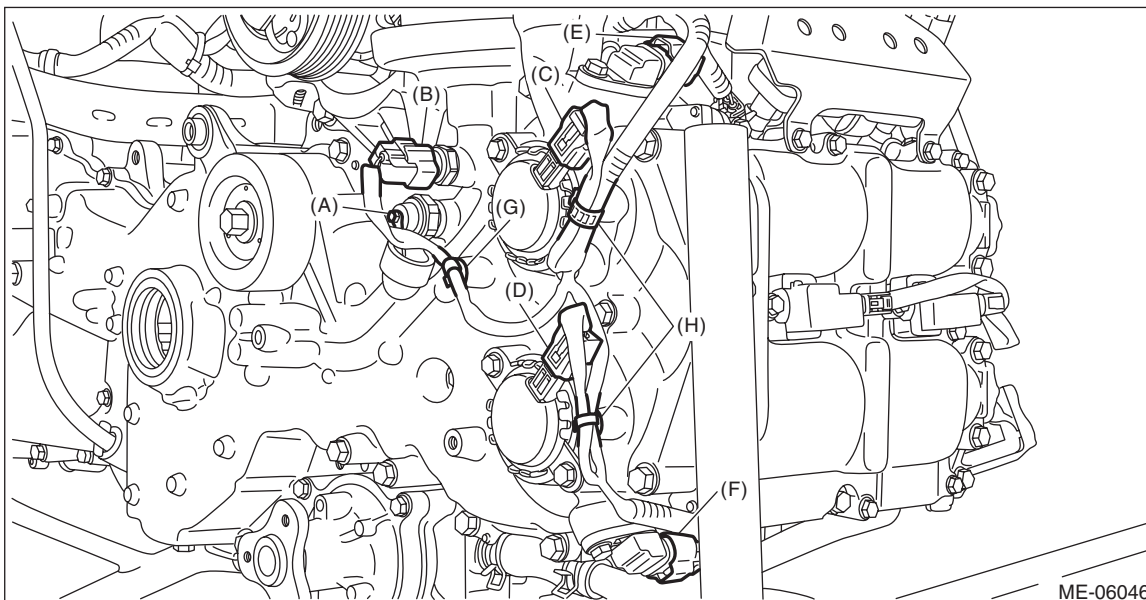

Chain Cover

MECHANICAL

7) Attach the rubber cap to the oil pressure switch.

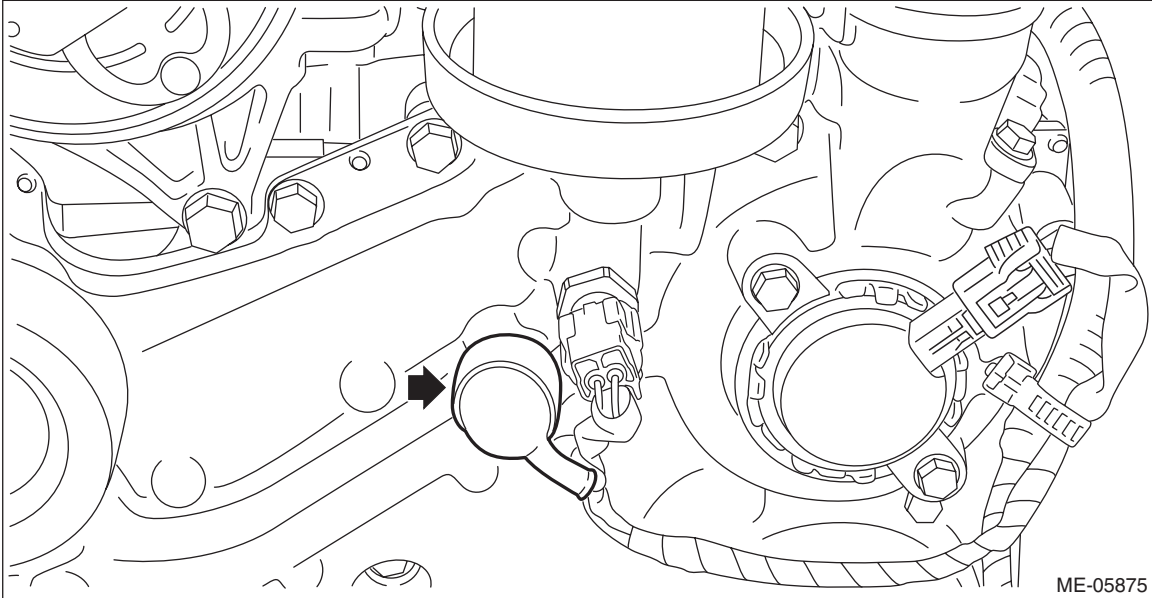

8) Secure the oil level switch harness with clips (A), and connect the connectors to the oil level switch.

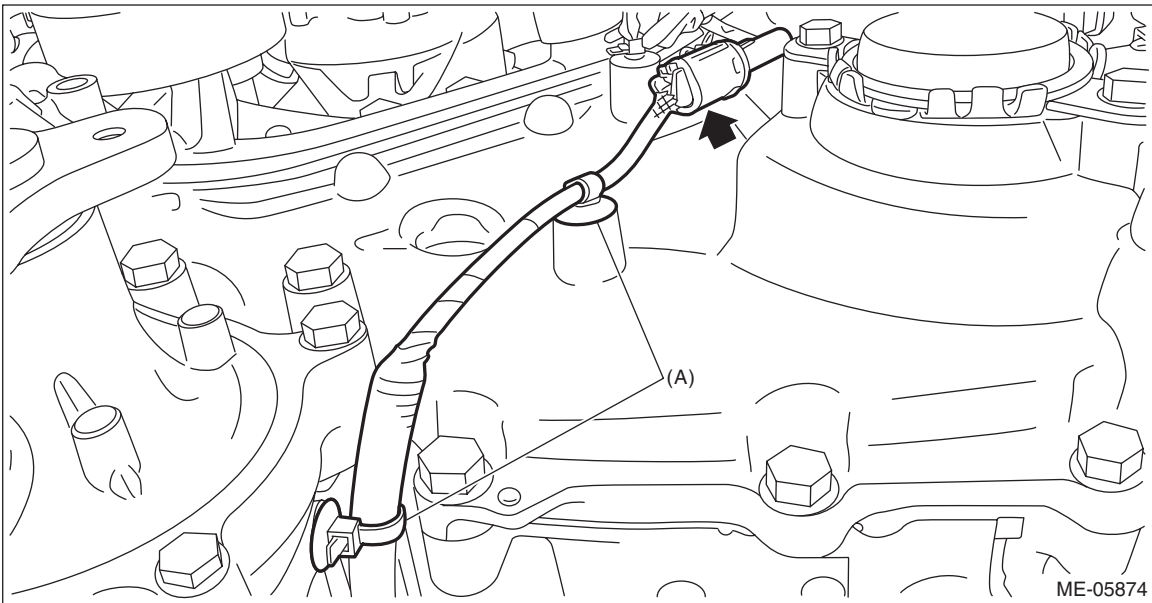

Chain Cover

MECHANICAL

9) Connect the connector (A) to the intake oil control solenoid RH, connector (B) to the exhaust oil control solenoid RH, and connector (C) to the intake camshaft position sensor RH, and then secure the engine harness with the clips (D) and (E).

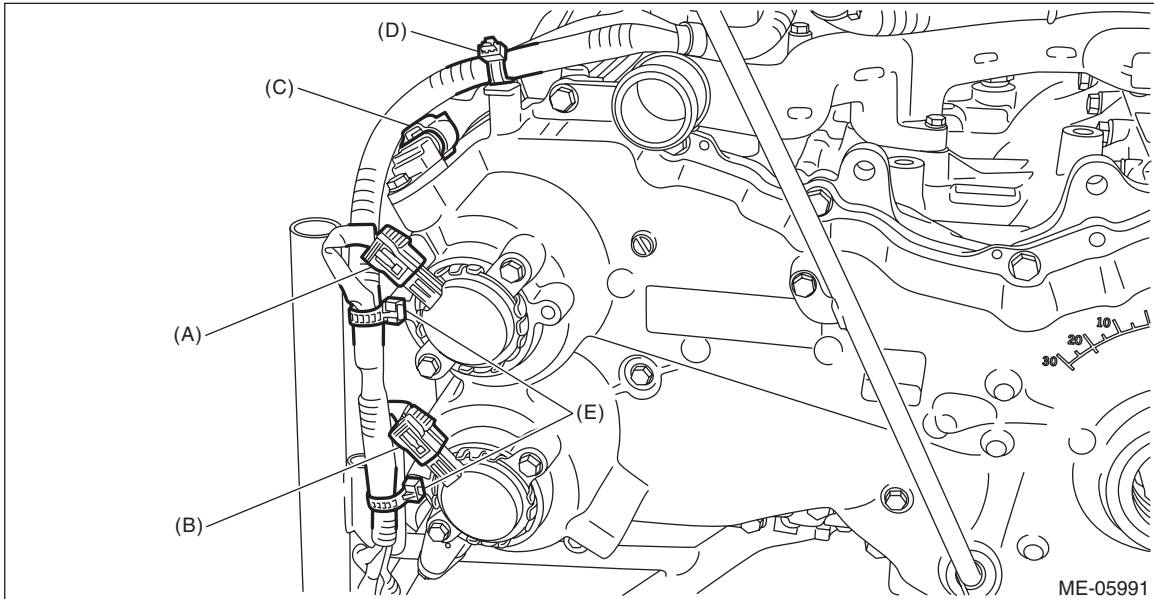

10) Connect the connector (A) to the exhaust camshaft position sensor RH, and install the engine harness stay to the chain cover.

Tightening torque:

6.4 N·m (0.7 kgf-m, 4.7 ft-lb)

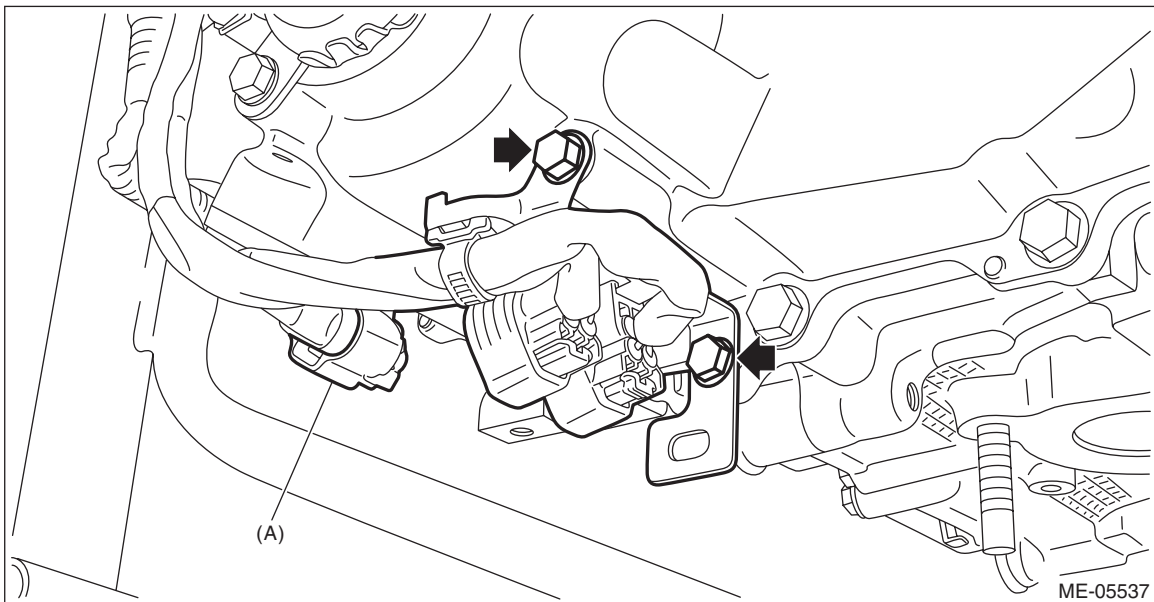

11) Install the crank pulley. <Ref. to ME(H4DO)-86, INSTALLATION, Crank Pulley.>

12) Install the water pump pulley. <Ref. to CO(H4DO)-18, WATER PUMP, INSTALLATION, Water Pump.>

13) Fill engine oil. <Ref. to LU(H4DO)-10, REPLACEMENT, Engine Oil.>

14) Install the generator bracket.

(1) Set the generator bracket to the engine, and tighten the bolts in numerical order as shown in the figure.

Tightening torque:

36 N·m (3.7 kgf·m, 26.6 ft·lb)

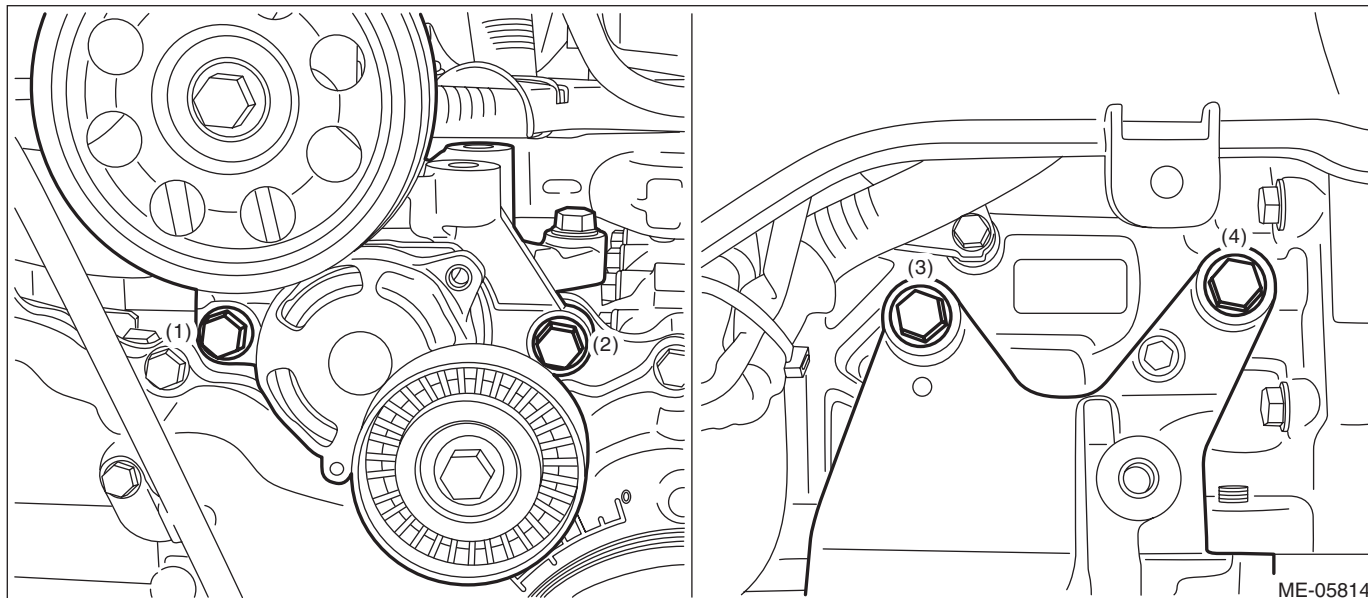

(2) Install the generator. <Ref. to SC(H4DO)-38, INSTALLATION, Generator.>

(3) Install the V-belts. <Ref. to ME(H4DO)-77, INSTALLATION, V-belt.>

15) When working on the vehicle

NOTE:

When working on the vehicle, perform the following steps also.

(1) Install the radiator. <Ref. to CO(H4DO)-36, INSTALLATION, Radiator.>

(2) Install the front exhaust pipe. <Ref. to EX(H4DO)-10, INSTALLATION, Front Exhaust Pipe.>

(3) Install the generator cord stay to the chain cover.

NOTE:

Install the generator cord stay so that the folded end (A) touches at the chain cover boss.

Tightening torque:

6.4 N·m (0.7 kgf·m, 4.7 ft·lb)

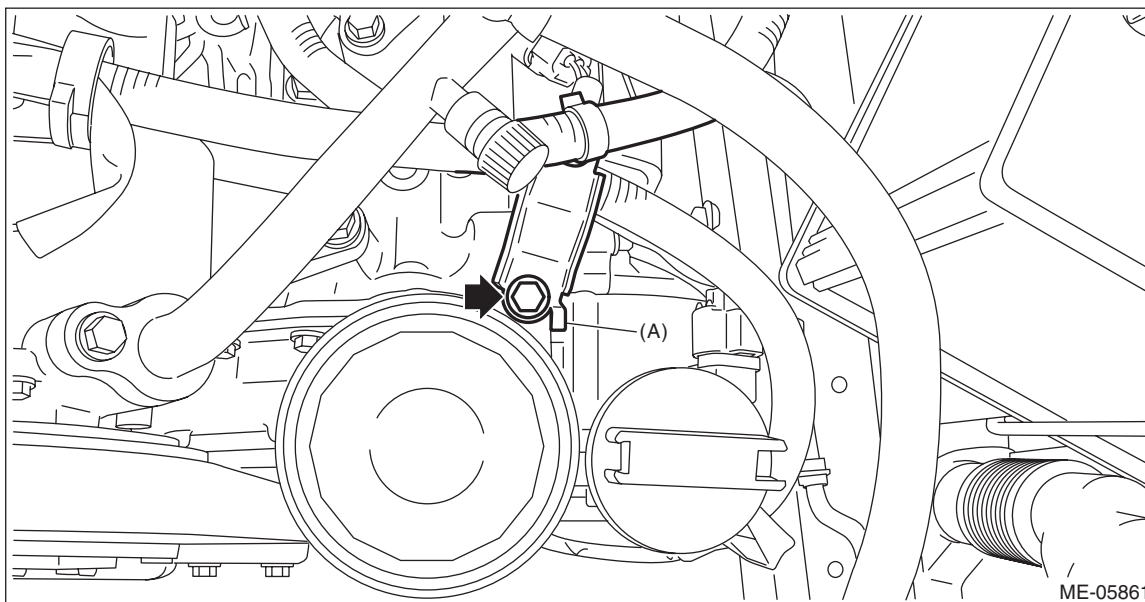

Chain Cover

MECHANICAL

C: DISASSEMBLY

- 1) Remove the oil filler cap.

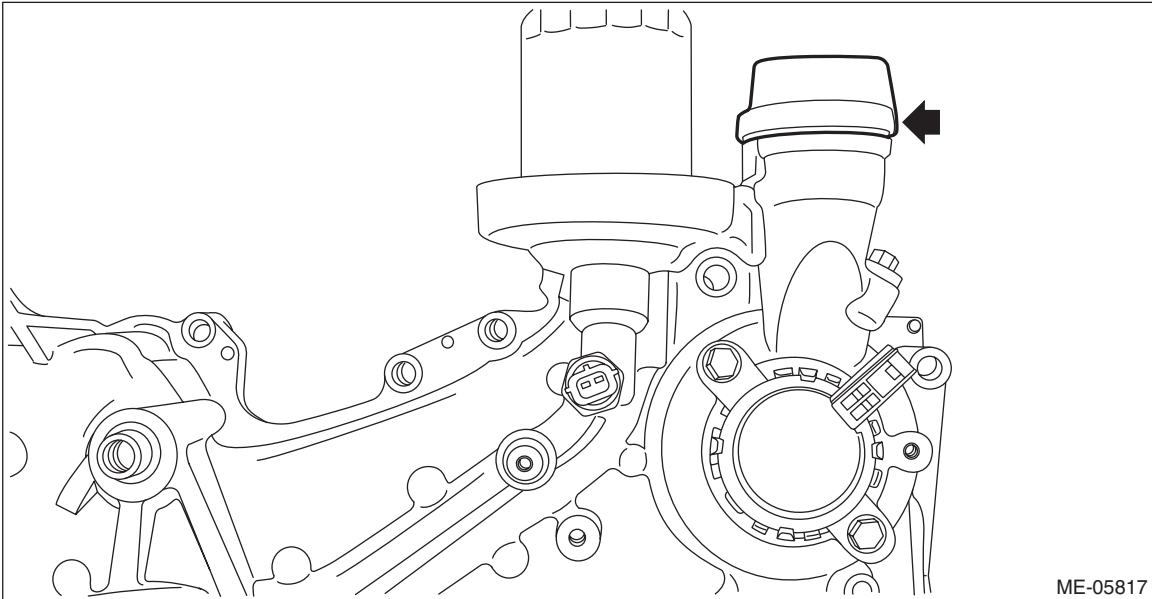

- 2) Remove the engine oil filter and the oil pump union. <Ref. to LU(H4DO)-27, REMOVAL, Engine Oil Filter.>
- 3) Remove the oil pressure switch. <Ref. to LU(H4DO)-22, REMOVAL, Oil Pressure Switch.>
- 4) Remove the engine oil temperature sensor. <Ref. to FU(H4DO)-49, REMOVAL, Engine Oil Temperature Sensor.>
- 5) Remove the oil control solenoid. <Ref. to FU(H4DO)-62, REMOVAL, Oil Control Solenoid.>
- 6) Remove the camshaft position sensor. <Ref. to FU(H4DO)-57, REMOVAL, Camshaft Position Sensor.>

D: ASSEMBLY

- 1) Install the camshaft position sensor. <Ref. to FU(H4DO)-59, INSTALLATION, Camshaft Position Sensor.>
- 2) Install the oil control solenoid. <Ref. to FU(H4DO)-64, INSTALLATION, Oil Control Solenoid.>
- 3) Install the engine oil temperature sensor. <Ref. to FU(H4DO)-49, INSTALLATION, Engine Oil Temperature Sensor.>
- 4) Install the oil pressure switch. <Ref. to LU(H4DO)-24, INSTALLATION, Oil Pressure Switch.>
- 5) Install the engine oil filter and the oil pump union. <Ref. to LU(H4DO)-28, INSTALLATION, Engine Oil Filter.>

6) Install the oil filler cap.

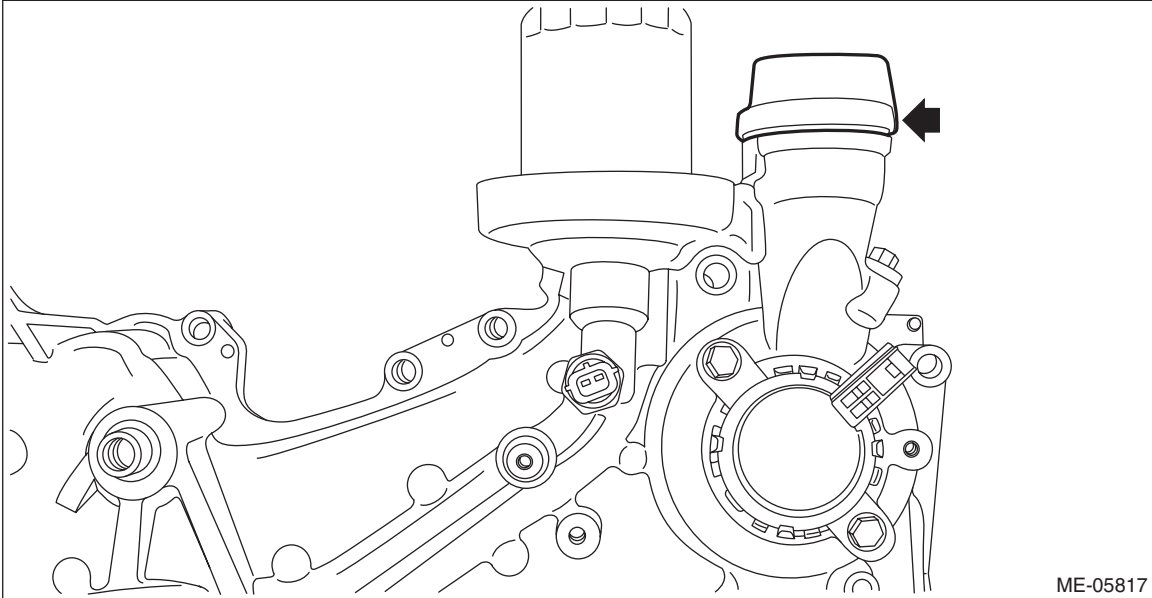

ME-05817

E: INSPECTION

Check that the chain cover does not have deformation, cracks and any other damage.