

## 37.Rearview Camera System

### A: WIRING DIAGRAM

#### 1. SEDAN MODEL (WITHOUT NAVIGATION SYSTEM)

RVCAM(S)-01

RVCAM(S)-01

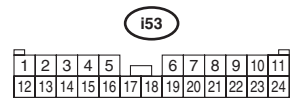
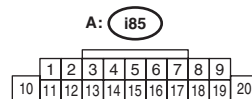
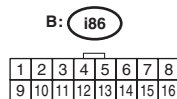
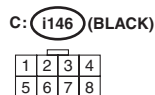
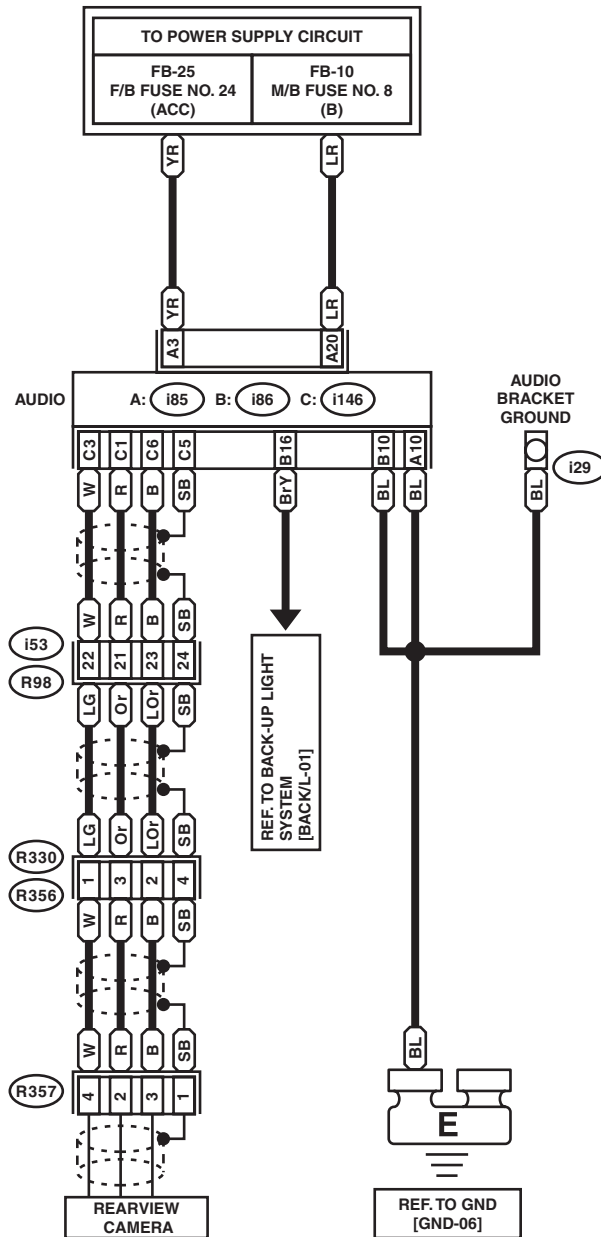

# Rearview Camera System

## WIRING SYSTEM

### 2. SEDAN MODEL (WITH NAVIGATION SYSTEM)

- Standard MFD

RVCAM(SN)-01

RVCAM(SN)-01

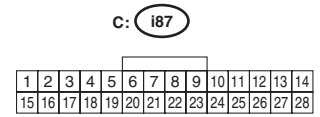
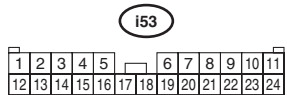
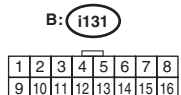
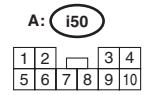
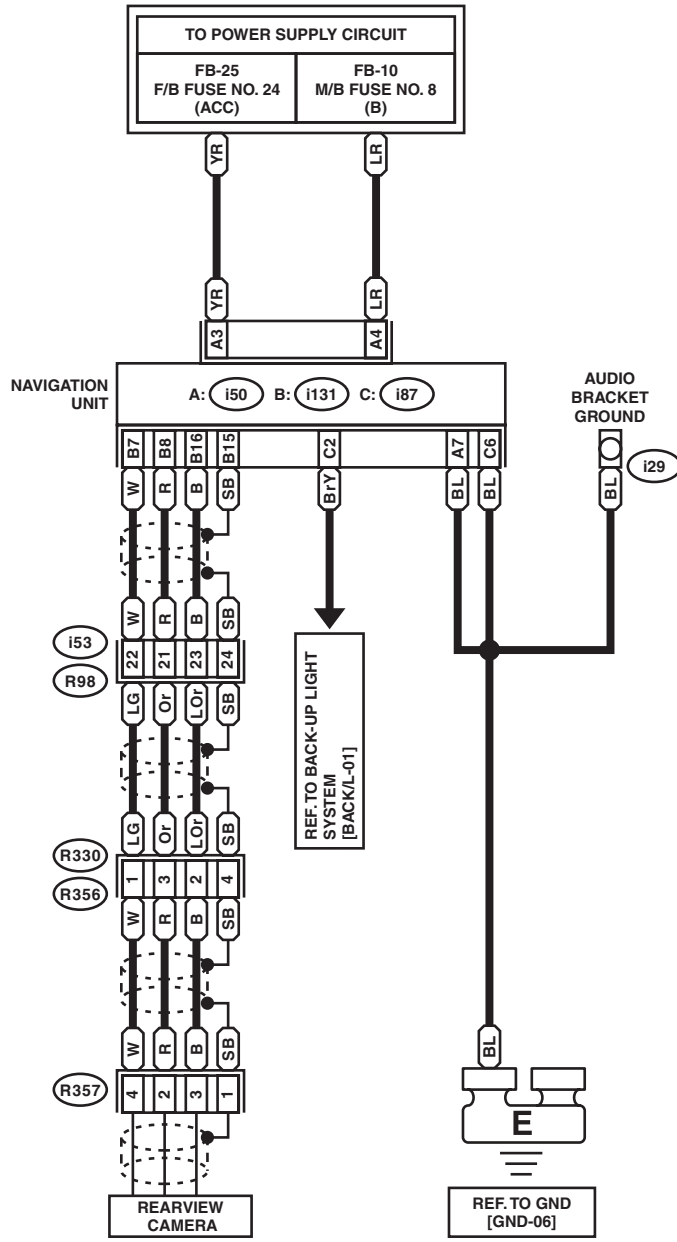

WI-37854

# Rearview Camera System

WIRING SYSTEM

- High grade MFD

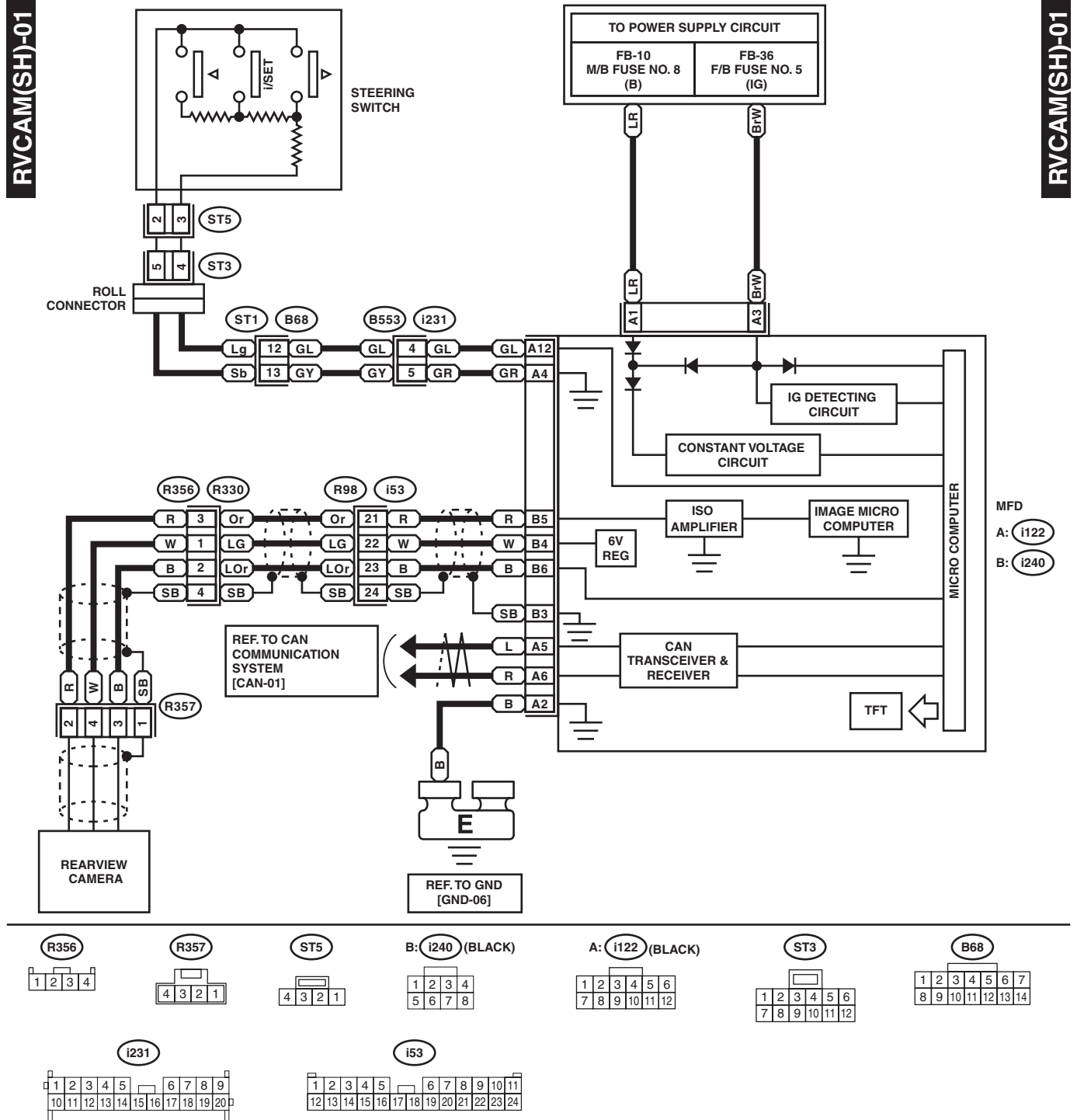

WI-37855

# Rearview Camera System

## WIRING SYSTEM

### 3. WAGON MODEL (WITHOUT NAVIGATION SYSTEM)

RVCAM(W)-01

RVCAM(W)-01

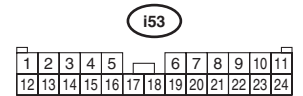
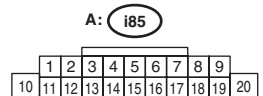
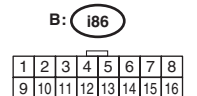
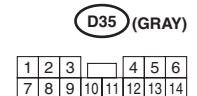
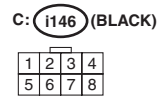
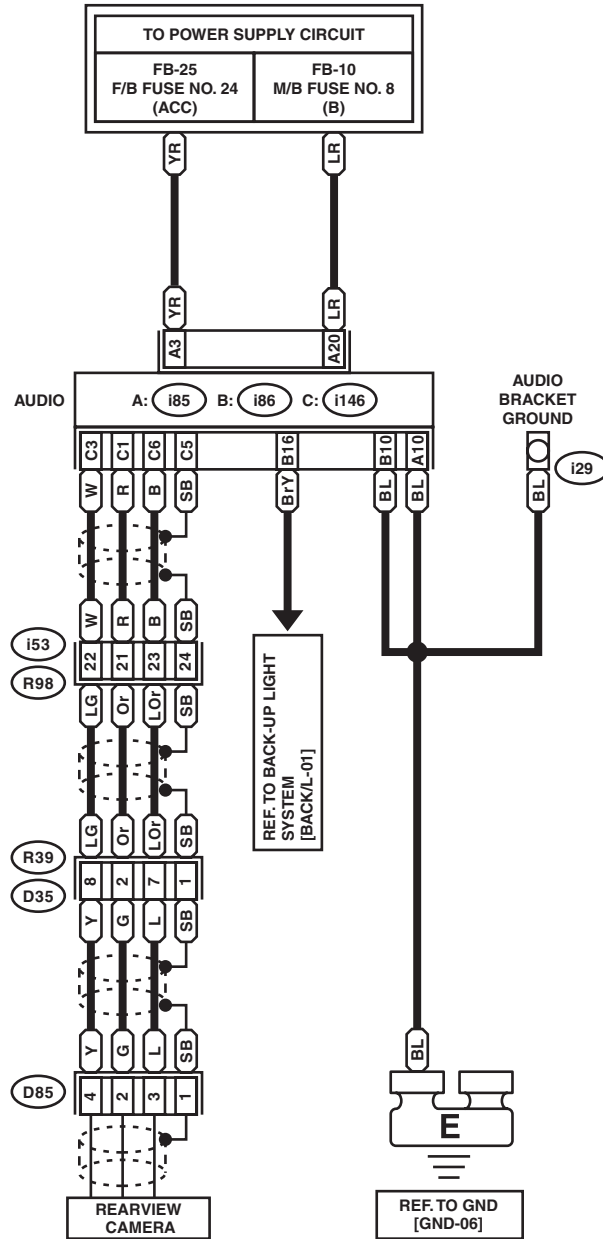

WI-37856

## 4. WAGON MODEL (WITH NAVIGATION SYSTEM)

- Standard MFD

RVCAM(WN)-01

RVCAM(WN)-01

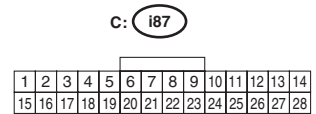
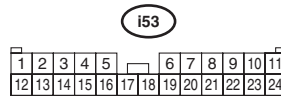
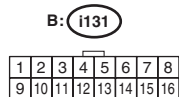
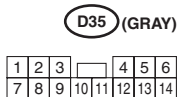
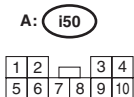
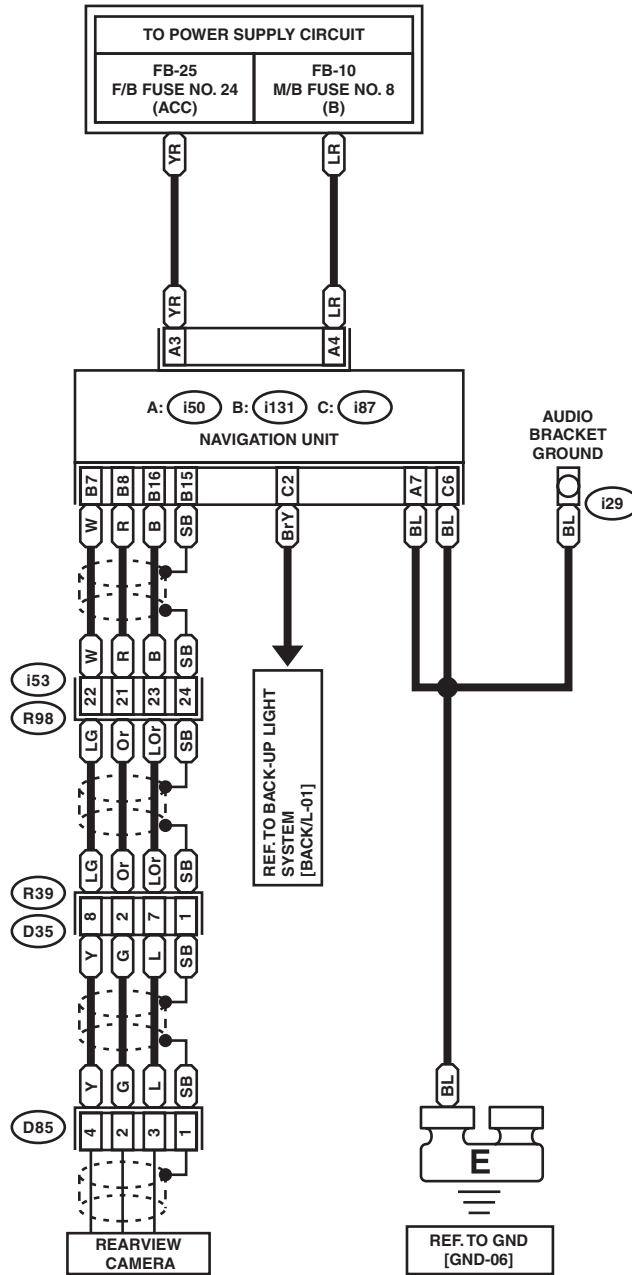

WI-37857

# Rearview Camera System

## WIRING SYSTEM

- High grade MFD

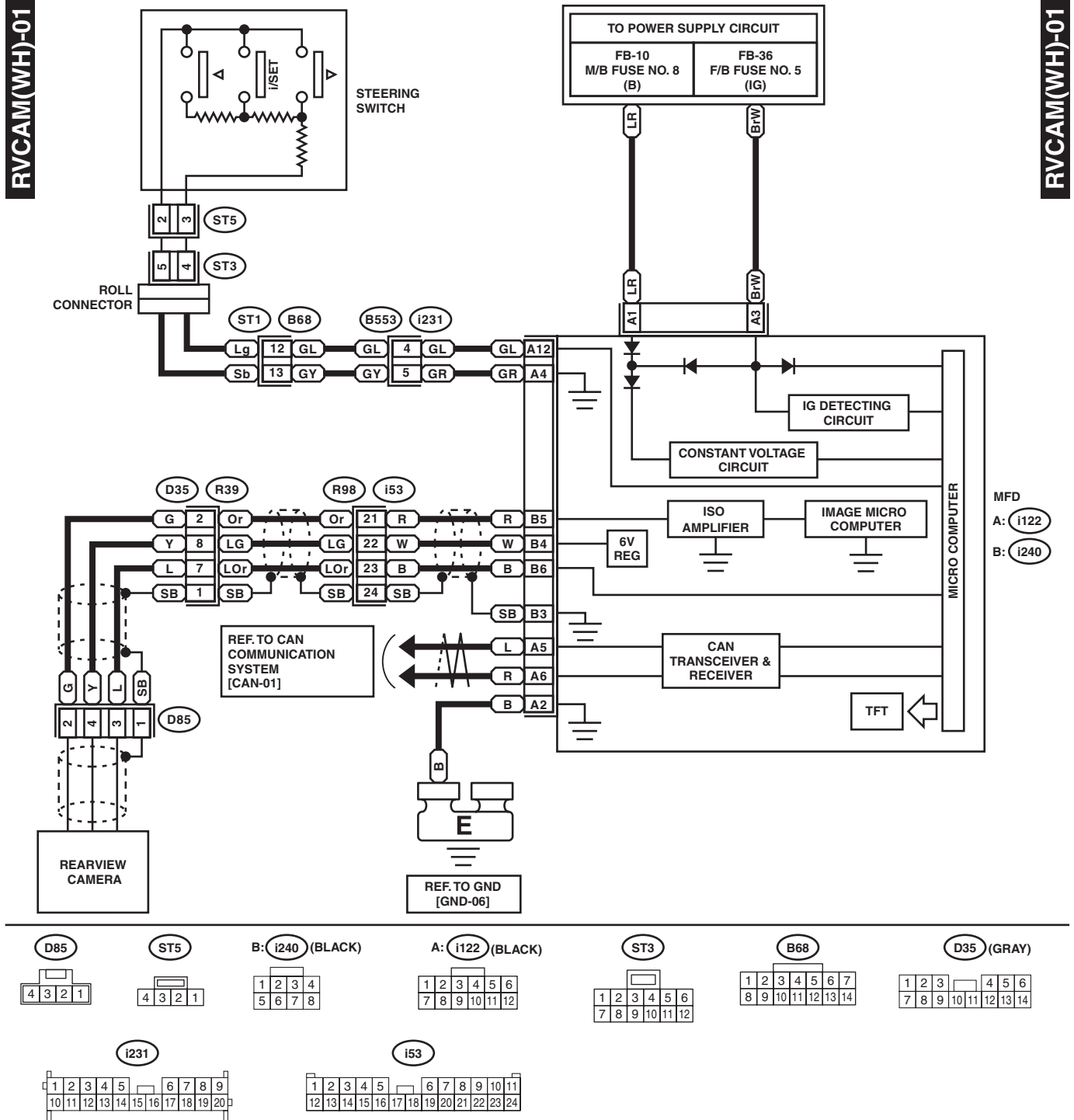

WI-37858